

Indexable inserts milling tool Program Wendeplatten Fräsprogramm

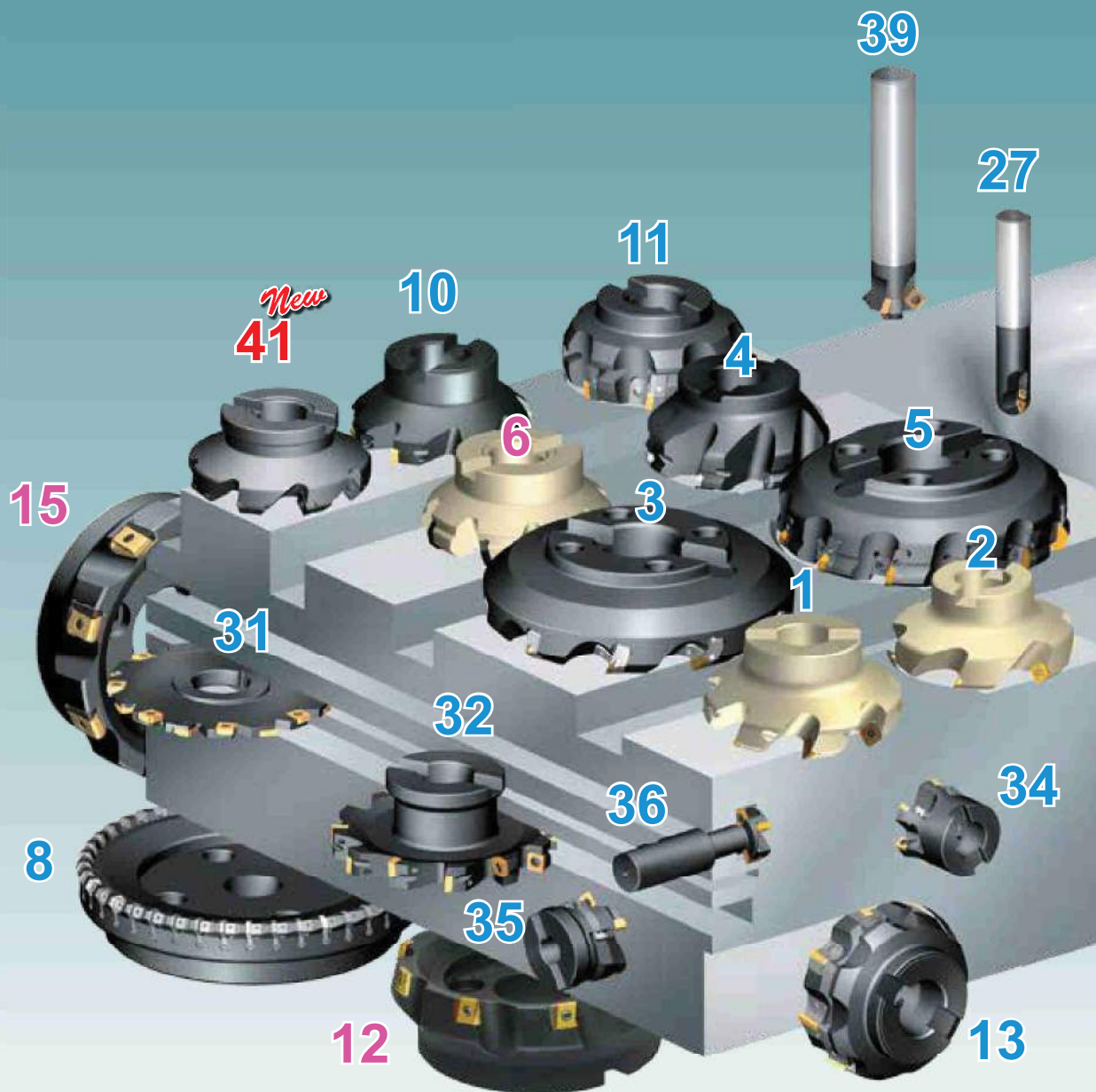

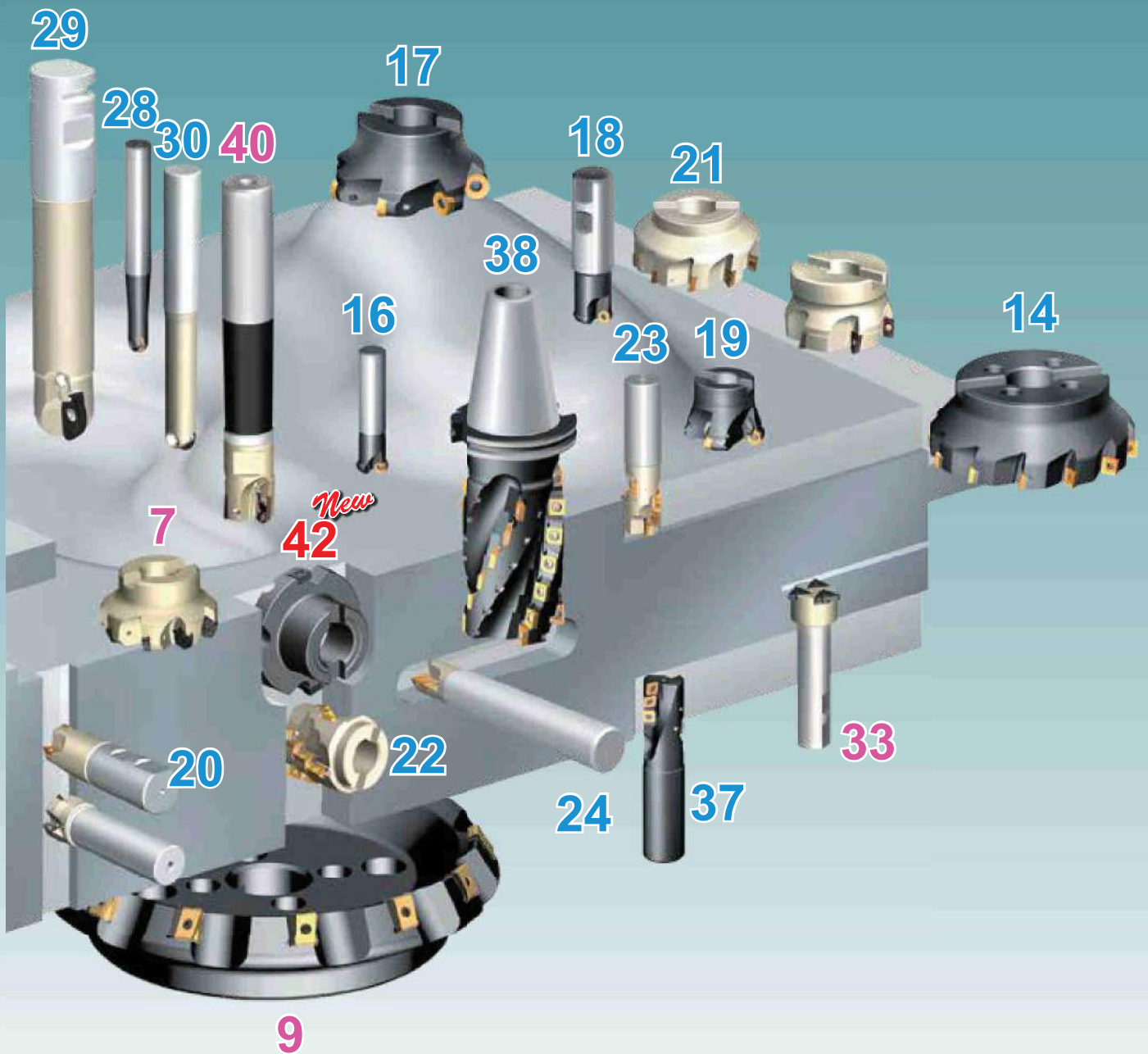







No. Nr.	Tool category Werkzeug Kategorie	Page Seite	No. Nr.	Tool category Werkzeug Kategorie	Page Seite	No. Nr.	Tool category Werkzeug Kategorie	Page Seite
1	FMA01	B28	9	FMD03	B55	17	FMR02	B79
2	FMA02	B29	10	FME02	B58	18	FMR03	B81
3	FMA03	B33	11	FME03	B60	19	FMR04	B84
4	FMA04(OFKT05**)	B36	12	FME04	B64	20	EMP01	B88
5	FMA04(OFKR07**)	B40	13	FMP01	B66	21	EMP02	B95
6	FMA07	B43	14	FMP02	B68	22	EMP03	B98
7	FMD02(PN11)	B49	15	FMP03	B74	23	EMP04	B99
8	FMD02(HN09)	B53	16	FMR01	B76	24	EMP05	B103



No. Nr.	Tool category Werkzeug Kategorie	Page Seite	No. Nr.	Tool category Werkzeug Kategorie	Page Seite	No. Nr.	Tool category Werkzeug Kategorie	Page Seite
27	BMR01	B105	35	XMR01(WPGT**)	B140	40	QCH	B160
28	BMR02	B107	36	TMP01	B149	41	FMA11	B46
29	BMR03	B109	37	HMP01(Ø40-Ø50)	B151	42	XMP01	B146
30	BMR04	B121	38	HMP01(Ø50-Ø80)	B152			
31	SMP01	B129		HMP01 EC(Ø50-Ø80)	B153			
32	SMP03	B132	39	CMA/CMD/CMZ	B156			

FMA07



		Approach Angle / max. depth of cut Einstellwinkel/ max. Schnitttiefe	Insert WSP	Application Anwendung	Features Merkmale
Face milling · Planfräsen	FMA01  B28	$K_r=45^\circ$ $a_{pmax}=6.0$	SEET12T3-DF/DM/DR SEET12T3-CF/CM/CR SEET12T3-EF/EM SEET12T3-LH SEET12T3-W	General face milling of: Steel, alloy steel, stainless steel, cast iron, aluminium alloy, high temperature alloy Allgemeines Planfräsen von: Stahl, leg. Stahl, rostfr. Stahl, Grauguss, Alu.-legierungen, hochtemperaturbeständige Legierungen	<ul style="list-style-type: none"> Diameter range Ø50-Ø315 Large rake angle makes cutting more light and fast Wide applications by using available inserts with different chipbreaker Adopting wiper inserts improve surface quality Durchmesserbereich: 50 – 315 mm weichschneidende Fräser mit großer, positiver Schneidengeometrie. Großes Anwendungsgebiet durch unterschiedliche Spanbrecherausführung Wiper-Wendeschneidplatten für beste Oberflächenqualität
	FMA02  B29	$K_r=45^\circ$ $a_{pmax}=6.0$	SEET12T3-DF/DM/DR SEET12T3-CF/CM/CR SEET12T3-EF/EM SEET12T3-LH SEET12T3-W	General face milling of: Steel, alloy steel, stainless steel, cast iron, aluminum alloy, high temperature alloy Allgemeines Planfräsen von: Stahl, leg. Stahl, rostfr. Stahl, Grauguss, Alu.-legierungen, hochtemperaturbeständige Legierungen	<ul style="list-style-type: none"> Diameter range Ø50-Ø125 Large rake angle makes cutting more light and fast Wide applications by using available inserts with different chipbreaker Coarse and differential pitch, reduce vibration. Durchmesserbereich: 50 – 125 mm weichschneidende Fräser mit großer, positiver Schneidengeometrie. Großes Anwendungsgebiet durch unterschiedliche Spanbrecherausführung Weite und Differential-Teilung zur Vermeidung von Vibrationen
	FMA03  B33	$K_r=45^\circ$ $a_{pmax}=5.5$	SEN120*3AF** SE*R1203AF**	General face milling of steel, stainless steel, cast iron Allgemeine Planfräsbear. von Stahl, rostfr. Stahl und Grauguss	<ul style="list-style-type: none"> Diameter range Ø80-Ø315 Large rake angle makes cutting more light and fast Top clamping reduces vibrations Durchmesserbereich: 80 – 315 mm weichschneidende Fräser mit großer, positiver Schneidengeometrie. Großes Anwendungsgebiet durch unterschiedliche Spanbrecherausführung Topklammung zur Vermeidung von Vibrationen
		$K_r=45^\circ$ $a_{pmax}=7.5$	SE*N1504AF** SE*R1504AF**		
	FMA04  B36  B40	$K_r=45^\circ$ $a_{pmax}=3.5$	OFKT05T3-DF/DM OFKT05T3-LH	Face milling of steel, alloy steel, cast iron, aluminum alloy Planfräsen von Stahl, leg. Stahl Grauguss und Alu.-legierungen	<ul style="list-style-type: none"> Diameter range Ø50-Ø160 High economy milling tool with 8 cutting edges Screw clamping, high precision Durchmesserbereich: 50 – 160 mm Hochwirtschaftlicher Fräser mit 8 Schneidkanten Schraubenklammung mit hoher Präzision. Topklammung zum leichteren Plattenwechsel
		$K_r=45^\circ$ $a_{pmax}=5.0$	OFKR0704-DF/DM	Face milling of steel, alloy steel and cast iron Planfräsen von Stahl, leg. Stahl und Grauguss	
	FMA07 New!  B43  B44	$K_r=45^\circ$ $a_{pmax}=4.0$	ONHU060408-PF/PM/WW	Face milling of steel, alloy steel, cast iron Planfräsen von Stahl und Grauguss	<ul style="list-style-type: none"> Diameter range Ø25-Ø50 High economy milling tool with 16 cutting edges Durchmesserbereich: 25 – 50 mm Hochwirtschaftliche Fräser mit 16 Schneidkanten
		$K_r=45^\circ$ $a_{pmax}=5.0$	ONHU08T508-PF/PM/WW		
	FMA11 New!  B46	$K_r=45^\circ$ $a_{pmax}=5.5$	SNEG 1205ANR-GM	Face milling of steel, alloy steel and cast iron Planfräsen von Stahl und Leg.Stahl Grauguss	<ul style="list-style-type: none"> Diameter range Ø63-Ø315 8 cutting edge Inserts with big rake angle cutting lightly reducing power consumption Milling cutter with double negative angle and with thicker inserts for high stability and big cutting depth. Inserts with wiper cutting edge for good surface quality. Durchmesserbereich: Ø63 – Ø315 mm 8 Schneidkanten Wandeschneidplatte mit großen Spanwinkel zur Reduzierung der Schnittkräfte Doppelseitige, extra dickewandeschneidplatte für große Spanliefen bei hoher bruchsicherheit Wiper Geometrie für beste Oberflächengüte
		$K_r=45^\circ$ $a_{pmax}=7.0$	SNEG 1506ANR-GM/GR		
$K_r=45^\circ$ $a_{pmax}=9.0$		SNEG 1907ANR-GM			







Milling - Fräsen

General Technical Information - Allgemeine Technische Informationen

B

Milling Tools
Fräser

Serie Serie	Approach Angle / max. depth of cut Einstellwinkel/ max. Schnitttiefe	Insert WSP	Application Anwendung	Features Merkmale
FMD02  B49-B52	$K_r=67^\circ$ $a_{pmax}=5.0$	PNEG110512R-CR PNEG110512R-CM PNEG110512R-PR PNEG110512R-PM	Face milling of cast iron Planfräsen von Stahl, leg. Stahl und Grauguss	<ul style="list-style-type: none"> Diameter range $\varnothing 50$-$\varnothing 315$ High economy milling tool with 10 cutting edges Durchmesserbereich: 50 – 315 mm Hochwirtschaftliche Fräser mit 10 Schneidkanten
FMD02  B53	$K_r=55^\circ$ $a_{pmax}=6.0$	HNEXT090512-DF/DM HNEXT090512-DR	Face milling of cast iron Planfräsen von Grauguss	<ul style="list-style-type: none"> Diameter range $\varnothing 80$-$\varnothing 315$ Top clamping is easy to assemble and disassemble High economy milling tool with 12 cutting edges Durchmesserbereich: 80 – 315 mm Topklemmsystem zum einfachen Wendeschneidplatten-Wechsel Hoch wirtschaftlich durch doppelseitige 12 Schneiden-Platte
FMD03  B55	$K_r=60^\circ$ $a_{pmax}=12.0$ $K_r=60^\circ$ $a_{pmax}=17.0$	LNKT2007DN-ZR LNKT2510-ZR	Heavy-duty face milling of steel, alloy steel and cast iron Schwerzer- spanungsfräsen von Stahl, leg. Stahl und Grauguss	<ul style="list-style-type: none"> Diameter rang $\varnothing 125$-$\varnothing 400$ Double positive rake angle reduces the cutting force Suitable for heavy machining with big cutting depth Easy to assemble and clamp inserts Durchmesserbereich: 125 – 400 mm Doppelt positive Schneidwinkel zur Reduzierung der Schnittkräfte Anwendung zur Schwerzerspannung bei hohen Schnitttiefen Einfache und stabile Wendeschneidplatten-Klemmung
FME02  B58	$K_r=75^\circ$ $a_{pmax}=6.0$	SPKW1204EDFR SPKW1204EDSR SPKT1204EDR	Face milling of steel, alloy of steel and cast iron Planfräsen von Stahl, leg. Stahl und Grauguss	<ul style="list-style-type: none"> Diameter range $\varnothing 50$-$\varnothing 125$ $K_r 75^\circ$, general face milling Wide applications by using inserts with different chipbreakers Durchmesserbereich: 50 – 125 mm Anstellwinkel 75 Grad, Allgemeines Planfräsen Weites Anwendungsgebiet durch Einsatz von Wendeschneidplatten mit unterschiedlichen Spanbrechern
FME03  B60	$K_r=75^\circ$ $a_{pmax}=6.0$	SP*N1203(1504)ED** SP*R1203(1504)ED**	General face milling of steel, alloy steel and cast iron	<ul style="list-style-type: none"> Diameter range $\varnothing 80$-$\varnothing 315$ $K_r 75^\circ$, general face milling Top clamping is easy to assemble and disassemble Durchmesserbereich: 80 – 315 mm Einstellwinkel 75 Grad zum allgemeinen Planfräsen Top Klemmsystem zum einfachen Wendeschneidplattenwechsel.
	$K_r=75^\circ$ $a_{pmax}=8.0$	SP*N1504ED** SP*R1504ED**	Allgemeines Planfräsen von Stahl, leg. Stahl und Grauguss	
FME04  B64	$K_r=75^\circ$ $a_{pmax}=10.0$	LNKT1506EN-ZR	Heavy-duty face milling of steel and alloy steel Schwerzer- spanungsfräsen von Stahl und leg. Stahl	<ul style="list-style-type: none"> Diameter rang $\varnothing 125$-$\varnothing 315$ Double positive rake angle reduces the cutting force Suitable for heavy machining with big cutting depth Durchmesserbereich: 125 – 315 mm Doppelt positive Schneidwinkel zur Reduzierung der Schnittkräfte Anwendung zur Schwerzerspannung bei hohen Schnitttiefen
FMP01  B66	$K_r=90^\circ$ $a_{pmax}=18.0$	TP*N2204PD* TPKN2204PDF* TPKN2204PDT*	Face milling of steel, alloy steel and cast iron Planfräsen von Stahl, leg. Stahl und Grauguss	<ul style="list-style-type: none"> Diameter range $\varnothing 80$-$\varnothing 315$ $K_r 90^\circ$, square shoulder milling Top clamping is easy to assemble and disassemble Durchmesserbereich: 80 – 315 mm Einstellwinkel 90 Grad zum allgemeinen Planfräsen Top-Klemmsystem zum einfachen Wendeschneidplattenwechsel.





Face milling - Planfräser		Serie Serie	Approach Angle / max. depth of cut Einstellwinkel/ max. Schnitttiefe	Insert WSP	Application Anwendung	Features Merkmale
 B68	Kr=90° a _p max=6.7	SEET09T308PER-PF/PM SEET09T308PER-PR	Face milling steel, alloy steel, stainless steel cast iron and Alu.	<ul style="list-style-type: none"> • Diameter range Ø50-Ø315 • Kr 90°, for square shoulder milling and face milling • Different pitch design: coarse pitch, close pitch and extra close pitch • High precision insert for, high surface quality • Optimized chipbreaker and grade, for finish machining, semi-finish machining and rough machining. 		
	Kr=90° a _p max=10.8	SEET120308PER-PF/PM SEET120308PER-PR			Plan- und Eckfräsen von Stahl, leg. Stahl, rostfr. Stahl Grauguss und Alu.	<ul style="list-style-type: none"> • Durchmesserbereich: 50 – 315 mm • Einstellwinkel 90 Grad zum Eck- und Planfräsen • Unterschiedliche Teilung: weit, eng und extra eng • Präzisionsschneidplatten zur Erzielung hoher Oberflächenqualität • Optimale Spanbrecher und Hartmetallsorten zum Schlichten, mittlere Bearbeitung und Schruppen.
 B74	Kr=90° a _p max=8	LNKT1506EN-ZR	Heavy Duty face milling steel, alloy steel, stainless steel and cast iron	<ul style="list-style-type: none"> • Diameter range Ø125-Ø315 • Kr 90°, for square shoulder milling and face milling with big cutting depth • positive rake reduces the cutting force • Durchmesserbereich: 125 – 315 mm • Einstellwinkel 90 Grad zum Schulter- und Planfräsen mit großer Schnitttiefe • Positiver Spanwinkel für weniger Schnittkräfte 		
	Kr=90° a _p max=12	LNKT2007DN-ZR	Schwerzerspan- nung von Stahl, leg. Stahl, rostfr. Stahl und Grauguss			
	Kr=90° a _p max=15	LNKT2510-ZR				
 B76	a _p max=5.0	RCKT10T3MO-DM	Cavity profile milling of steel, alloy steel, stainless steel and cast iron	<ul style="list-style-type: none"> • Diameter range Ø25-Ø50 • R-type inserts possess stronger cutting edges • Suitable for machining curved surface of mould • Economical milling cutters with screw clamping • Durchmesserbereich: 25 – 50 mm • Radiusfräser mit stabiler Schneidkante • Einsatz zur Bearbeitung von Formen und Gesenken • Wirtschaftliche Fräser mit Schraubenklammerung 		
	a _p max=6.0	RCKT1204MO-DM/DR	Formfräsen von Stahl, leg. Stahl, rostfr. Stahl und Grauguss			
 B79	a _p max=6.0	RCKT1204MO-DM/DR/ER	Face milling and cavity profile milling of steel, alloy steel, stainless steel and cast iron	<ul style="list-style-type: none"> • Diameter range Ø63-Ø200 • R-type inserts possess stronger cutting edges • Suitable for machining curved surface of mould • Economical milling tools with screw clamping • Durchmesserbereich: 63 – 200 mm • Radiusfräser mit stabiler Schneidkante • Einsatz zur Bearbeitung von Formen und Gesenken • Wirtschaftliche Fräser mit Schraubenklammerung 		
	a _p max=8.0	RCKT1606MO-DM/DR/ER	Plan- und Formfräsen von Stahl, leg. Stahl, rostfreiem Stahl und Grauguss			
	a _p max=10.0	RCKT2006MO-DM/DR/ER				
 B81	a _p max=4.0	RDKW0702MO RDKW0803MO	Cavity profile milling of steel, alloy steel, stainless steel and cast iron	<ul style="list-style-type: none"> • Diameter range Ø25-Ø50 • R-type inserts possess stronger cutting edges • Suitable for machining curved surface of mould • Economical milling tools with screw clamping • Durchmesserbereich: 25 – 50 mm Radiusfräser mit stabiler Schneidkante • Einsatz zur Bearbeitung von Formen und Gesenken • Wirtschaftliche Fräser mit Schraubenklammerung 		
	a _p max=5.0	RDKW1003MO RDKW10T3MO	Formfräsen von Stahl, leg. Stahl, rostfreiem Stahl und Grauguss			
	a _p max=6.0	RDKW1204MO RDKW12T3MO				
 B84	a _p max=6.0	RDKW1204MO RDKW12T3MO	Face milling and cavity profile milling of steel, alloy steel, stainless steel and cast iron	<ul style="list-style-type: none"> • Diameter range Ø50-Ø160 • R-type inserts possess stronger cutting edge • Suitable for machining curved surface of mould • Durchmesserbereich: 50 – 160 mm • Radiusfräser mit stabiler Schneidkante • Einsatz zur Bearbeitung von Formen und Gesenken • Wirtschaftliche Fräser mit Schraubenklammerung 		
	a _p max=8.0	RDKW1604MO RDKW1605MO	Plan- und Formfräsen von Stahl, leg. Stahl, rostfreiem Stahl und Grauguss			
	a _p max=10.0	RDKW2006MO				









Milling - Fräsen

General Technical Information - Allgemeine Technische Informationen

B

Milling Tools
Fräser

	Serie Serie	Approach Angle / max. depth of cut Einstellwinkel/ max. Schnitttiefe	Insert WSP	Application Anwendung	Features Merkmale
Square shoulder milling · Eckfräsen	EMP01  B88	Kr=90° $a_{pmax}=10.5$	APKT11T3**-PF/PM/ PR APKT11T3**-LH	Multi-function milling of steel, alloy steel, stainless steel, cast iron and Al alloy	<ul style="list-style-type: none"> Two mounting modes: Straight shank and Weldon shank, Diameter range Ø12-Ø63. Kr 90° , for square shoulder milling, slot milling, ramp milling etc. Wiper inserts also suitable for face milling. Inserts with 3D helical cutting edge, less cutting force.
		Kr=90° $a_{pmax}=15.5$	APKT160408- PF/PM/ PR APKT160408-LH	Universelles Fräsen von Stahl, leg. Stahl, rostfr. Stahl, Grauguss und leg. Alu.	<ul style="list-style-type: none"> Zwei Aufnahmeversionen: Zylinderschaft u. Weldon. Durchmesserbereich: 12 – 63 mm. Einstellwinkel 90 Grad, zum Eck-, Nuten-, Tauchfräsen etc. Wiper-Schneidplatten zum Planfräsen. Schneidplatte mit 3-D Spiral-Schneide zur Reduzierung der Zerspanungskräfte.
	EMP02  B95	Kr=90° $a_{pmax}=10.5$	APKT11T3**- PF/PM/ PR APKT11T3**-LH	Face milling of steel, alloy steel, stainless steel, cast iron and Al alloy	<ul style="list-style-type: none"> Diameter range Ø50-Ø100. Kr 90° , for square shoulder milling. Wiper inserts also suitable for face milling. Inserts with 3D helical cutting edge, less cutting force.
		Kr=90° $a_{pmax}=15.5$	APKT160408- PF/PM/ PR APKT160408-LH	Universelles Fräsen von Stahl, leg. Stahl, rostfr. Stahl, Grauguss und leg. Alu.	<ul style="list-style-type: none"> Durchmesserbereich: 50 – 100 mm. Einstellwinkel 90 Grad zum Eckfräsen. Wiper-Schneidplatten zum Planfräsen Schneidplatte im 3-D Design. Zirkularschneide zur Reduzierung der Zerspanungskräfte.
	EMP03  B98	Kr=90° $a_{pmax}=39.0$	APKT11T3**-PF/PM/ PR APKT11T3**-LH	Adopting large cutting depth, for milling of steel, alloy steel, stainless steel, cast iron and Al alloy Fräsen mit großen Schnitttiefen von Stahl, leg. Stahl, rostfr. Stahl, Grauguss und leg. Alu.	<ul style="list-style-type: none"> Diameter range Ø50-Ø100 End milling tools with positive helical angle, good chip removal. For side face milling and slot machining Close pitch, high machining efficiency. Durchmesserbereich: 50 – 100 mm. Eckfräser mit pos. Zirkularwinkel und guter Spanabfuhr. Eck- und Nutenfräsen. Enge Teilung zur Erreichung hoher Bearbeitungswirtschaftlichkeit.
	EMP04  B99	Kr=90° $a_{pmax}=58.0$	APKT11T3**-PF/PM/ PR APKT11T3**-LH	Adopting large cutting depth, for milling steel, alloy steel, stainless steel, cast iron and Al alloy. Fräsen mit großen Schnitttiefen von Stahl, leg. Stahl, rostfr. Stahl, Grauguss und leg. Alu.	<ul style="list-style-type: none"> Diameter range Ø20-Ø40 End milling tools with positive helical angle, good chip removal For side face milling and slot machining Close pitch, high machining efficiency. Durchmesserbereich: 20 – 40 mm. Schafffräser mit pos. Zirkularwinkel und guter Spanabfuhr. Eck- und Nutenfräsen. Enge Teilung zur Erreichung hoher Bearbeitungswirtschaftlichkeit.
EMP05  B103	Kr=90° $a_{pmax}=40.0$	APMT1135PDR APMT160408PDER	Multi-function drilling and milling steel alloy steel, stainless steel and cast iron Multi-Funktionsbohren und Fräsen von Stahl, leg. Stahl, rostfr. Stahl und Grauguss	<ul style="list-style-type: none"> Diameter range Ø25-Ø40 End edge over center, for drilling directly. Durchmesserbereich: 25 – 40 mm. Zentrum-Schneide (über Mitte) zum Bohren. 	











	Serie Serie	Approach Angle / max. depth of cut Einstellwinkel/ max. Schnitttiefe	Insert WSP	Application Anwendung	Features Merkmale
Profile milling Formfräse	BMR01  B105	Cutting depth: see the detailed information about tool specifications Schnitttiefe: siehe detaillierte Info in der Werkzeug- spezifikation.	ZDET**CYR** ZPNT2204CYR** SPMT060304 SDMT**	Profile machining of steel, stainless steel and cast iron Formfräsen von Stahl, rostfreiem Stahl und Grauguss.	<ul style="list-style-type: none"> • Diameter range Ø20-Ø63 • Very suitable for rough machining large mold • Ball nose cutter with 3-cutting-edges inserts, perfect economical efficiency • Durchmesserbereich: 20 – 63 mm • Besonders geeignet für die Schruppbearbeitung von großen Formen • Radiusfräser mit 3 Schneidkanten pro Schneidplatte. • Hohe Wirtschaftlichkeit
	BMR02  B107		ROHX**	Profile machining of steel, stainless steel and cast iron Formfräsen von Stahl, rostfreiem Stahl und Grauguss.	<ul style="list-style-type: none"> • Diameter range Ø12-Ø20 • Applied for profile finish machining • Good assembly stability. • Insert with two cutting edges, perfect economical efficiency. • Durchmesserbereich: 12 – 20 mm • Schlichtbearbeitung von Formen • Hohe Fräserstabilität • Schneidplatte mit 2 Schneidkanten • Hohe Wirtschaftlichkeit
	BMR03  B109  B110  B111  B112		XPHT**R**- GM	Profile machining of steel, stainless steel and cast iron Formfräsen von Stahl, rostfreiem Stahl und Grauguss.	<ul style="list-style-type: none"> • Diameter range Ø16-Ø50 • Very suitable for rough machining moulds • Equipped with 3D chipbreaker inserts, high circular edge precision. • Tool body with high rigidity • Durchmesserbereich: 16 – 50 mm • Besonders geeignet für das Schruppfräsen von Formen. • 3-D Spanbrecher für hohe Rundlaufgenauigkeit • Werkzeugkörper mit hoher Stabilität
	BMR04  B121  B122		ZOHX**	Profile machining of steel, stainless steel and cast iron Formfräsen von Stahl, rostfreiem Stahl und Grauguss.	<ul style="list-style-type: none"> • Diameter range Ø10-Ø40 • High precision, for finish profile machining. • Two types of chipbreaker, used at different machining condition • High assembling precision, good stability. • Durchmesserbereich: 10 – 40 mm • Hohe Präzision zur Fertigbearbeitung beim Formfräsen. • 2 Spanbrechergeometrien für unterschiedliche Anwendungen • Hohe Fräserstabilität und Präzision.







Milling - Fräsen

General Technical Information - Allgemeine Technische Informationen

B

Milling Tools
Fräser

	Serie Serie	Approach Angle / max. depth of cut Einstellwinkel/ max. Schnitttiefe	Insert WSP	Application Anwendung	Features Merkmale
Slot milling Nutenfräsen	SMP01  B129  B130	Cutting depth: see the detailed information about tool specifications	XSEQ12□□	Slot milling of steel, stainless steel and cast iron. Nutenfräsen von Stahl und Grauguss	<ul style="list-style-type: none"> • Diameter range Ø100-Ø250 • Two mounting types • Groove width range : 4, 5, 6, 7, 8mm • Durchmesserbereich Ø100-Ø250 • Zwei Aufnahme Typen • Nutenbreiten Bereich : 4, 5, 6, 7, 8mm
	SMP03  B132  B133	Schnitttiefe: siehe detaillierte Info in der Werkzeug- spezifikation.	MPHT□□	Slot milling of steel, stainless steel and cast iron. Nutenfräsen von Stahl und Grauguss	<ul style="list-style-type: none"> • Diameter range Ø80-Ø250 • Two mounting types • Groove width range : 4, 5, 6, 7, 8mm • Durchmesserbereich Ø80-Ø250 • Zwei Aufnahme Typen • Nutenbreiten Bereich : 4, 5, 6, 7, 8mm
	SMP05 New!  B135	Cutting depth: see the detailed information about tool specifications Schnitttiefe: siehe detaillierte Info in der Werkzeug- spezifikation.	QC16L□□ QC22L□□	Slot milling of steel, stainless steel and cast iron. Nutenfräsen von Stahl und Grauguss	<ul style="list-style-type: none"> • Diameter range Ø25-Ø44 • Durchmesserbereich Ø25-Ø44
Special milling (high feed) Spezialfräsen für hohe Vorschübe	XMR01  B138  B138  B140  B141	Cutting depth: see the detailed information about tool specifications Schnitttiefe: siehe detaillierte Info in der Werkzeug- spezifikation.	SDMT□□-DM WPGT□□ZSR	Face and profile milling of steel, stainless steel and cast iron in cavity applications Plan- und Formfräsen von Stahl, rostfreiem Stahl und Grauguss	<ul style="list-style-type: none"> • Diameter range Ø25-Ø100 • Two mounting types: Straight shank and Arbor • The cutting forces are decomposed effectively, realize cutting with high feed rate. • For plunge milling • Double clamping, firm and reliable. • Durchmesserbereich Ø25-Ø100 • als Schaft- und Aufsteckfräser • Die Schnittkräfte werden axial konzentriert. Der Fräser ist für hohe Vorschübe geeignet. • Tauchfräsen möglich. • Doppeltes Klemmsystem für WSP. • Diameter range Ø20-Ø100 • Two mounting types: Straight shank and Arbor • The cutting forces are decomposed effectively, realize cutting with high feed rate. • Double clamping, firm and reliable. • Durchmesserbereich Ø25-Ø100 • als Schaft und Aufsteckfräser • Die Schnittkräfte werden axial konzentriert. Der Fräser ist für hohe Vorschübe geeignet. • Doppeltes Klemmsystem für WSP.
	XMP01 New!  B146	Kr=90° a _p max=15~90	CNE121006A/B	Face milling, side milling, and boring milling Fräsen für Aufbohren, Planfräsen, Eckfräsen	<ul style="list-style-type: none"> • Diameter range Ø80-Ø400 • Kr=90° • Good for helica milling • Two types of vertical inserts for different material CNE 121006A with sharper cutting edge. CNE 121006B with chamfer • Durchmesserbereich Ø80-Ø400 • Kr=90° • Geeignet für Fräsen in Spiralinterpolation • Zwei WSP-Geometrie für verschiedene Materialien und Bearbeitungen. CNE 121006A mit schärferen Schneidkanten. CNE 121006B mit Schutzschneidkanten.









	Serie Serie	Approach Angle / max. depth of cut Einstellwinkel/ max. Schnitttiefe	Insert WSP	Application Anwendung	Features Merkmale
T-slot milling T-Nutenfräsen	TMP01  B149	Kr=90°	MPHT**	Machining T slot in cast iron T-Nuten von Gusseisen	<ul style="list-style-type: none"> • Diameter range Ø21-Ø60 • Machining the T-slot with size range 12, 14, 18, 22, 28, 36 mm. • 86° rhombic inserts with positive angle. • Durchmesserbereich Ø21-Ø60 • T-Nutenfräsen im Bereich von 12, 14, 18, 22, 28, 36mm. • 86° rhombische WSP mit positivem Winkel.
Helical end mills Walzenstirnfräser	HMP01  B151	Kr=90° a _p max=55	APKT150412-PM/ KM SPMT120408-PM/ KM	Milling of steel, alloy steel and cast iron with large cutting depth. Fräsen von Stahl, leg. Stahl und Grauguss. Bei großen Schnitttiefen.	<ul style="list-style-type: none"> • Diameter range Ø40-Ø80 • Coarse and differential pitch, less vibration • Holistic structure with good rigidity, interchangeable heads achieve high economical efficiency. • Durchmesserbereich Ø40-Ø80 • Weite und normale Teilung, weniger Vibrationen • Holistische Struktur mit hoher Stabilität, austauschbare Fräsköpfe für hohe Effizienz und Wirtschaftlichkeit.
	 B152	Kr=90° a _p max=144			
	HMP01 EC  B153	Kr=90° a _p max=144			
Chamfer milling Fasenfräser	CMZ01  B156	Kr=30°	SPMT120408	Chamfer machining of steel, alloy steel, stainless steel and cast iron Fasenfräsen von Stahl, leg. Stahl, rostfreiem Stahl und Gusseisen	<ul style="list-style-type: none"> • Diameter range Ø12, Ø25, Ø32, Ø36 • With the function of milling small surface • Durchmesserbereich Ø12, Ø25, Ø32, Ø36 • Einsatz bei kleinen Flächen
	CMA01  B157	Kr=45°			
	CMD01  B158	Kr=60°			

Milling - Fräsen

General Technical Information - Allgemeine Technische Informationen

B

Milling Tools
Fräser

New!	Serie Serie	Approach Angle / max. depth of cut Einstellwinkel/ max. Schnitttiefe	Insert WSP	Application Anwendung	Features Merkmale	
Replacingshead milling Wechselkopf-Fräser	 B163	Cutting depth: see the detailed information about tool specifications Schnitttiefe: siehe detaillierte Info in der Werkzeug- spezifikation.	XPHT**	Profile machining of steel, stainless steel and cast iron. Formfräsen von Stahl, rostfreiem Stahl und Grauguss.	<ul style="list-style-type: none"> • Diameter range Ø16-Ø32 • Very suitable for rough machining moulds. • Equipped with 3D chipbreaker inserts, high circular edge precision. • Tool body with high rigidity. • Durchmesserbereich: Ø16-Ø32. • Besonders geeignet für das Schrufffräsen von Formen. • 3-D Spanbrecher für hohe Rundlaufgenauigkeit • Werkzeugkörper mit hoher Stabilität 	
	 B166		SDMT**	Face milling and cavity profile milling of steel, alloy steel, stainless steel and cast iron. Plan- und Formfräsen von Stahl, leg. Stahl, rostfreiem Stahl und Grauguss.	<ul style="list-style-type: none"> • Diameter range Ø25-Ø35. • The cutting forces are decomposed effectively, realize cutting with high feed rate. • For plunge milling • Double clamping, firm and reliable. • Durchmesserbereich Ø25-Ø35. • Die Schnittkräfte werden axial konzentriert. Der Fräser ist für hohe Vorschübe geeignet. • Tauchfräsen möglich. • Doppeltes Klemmsystem für WSP. 	
	 B167		WPGT**	Face milling and cavity profile milling of steel, alloy steel, stainless steel and cast iron. Plan- und Formfräsen von Stahl, leg. Stahl, rostfreiem Stahl und Grauguss.	<ul style="list-style-type: none"> • Diameter range Ø20-Ø35. • The cutting forces are decomposed effectively, realize cutting with high feed rate. • Double clamping, firm and reliable. • Durchmesserbereich Ø25-Ø35. • Die Schnittkräfte werden axial konzentriert. Der Fräser ist für hohe Vorschübe geeignet. • Doppeltes Klemmsystem für WSP. 	
	 B170		APKT**	Multi-function milling of steel, alloy steel, stainless steel, cast iron and Al alloy. Multi-Funktionsbohren und Fräsen von Stahl, leg. Stahl, rostfr. Stahl und Grauguss.	<ul style="list-style-type: none"> • Diameter range Ø16-Ø30 • Kr 90° , for square shoulder milling • Wiper inserts also suitable for face milling. • Inserts with 3D helical cutting edge, less cutting force. • Durchmesserbereich: 16 – 30 mm • Einstellwinkel 90 Grad zum Eckfräsen • Wiper-Schneidplatten zum Planfräsen • Schneidplatte im 3-D Design • Zirkularschneide zur Reduzierung der Zerspanungskräfte 	
	 B175		RDKW**	Face milling and cavity profile milling of steel, alloy steel, stainless steel and cast iron. Plan- und Formfräsen von Stahl, leg. Stahl, rostfreiem Stahl und Grauguss.	<ul style="list-style-type: none"> • Diameter range Ø16-Ø32. • R-type inserts possess stronger cutting edge • Suitable for machining curved surface of mould • Economical milling cutters with screw clamping. • Durchmesserbereich: 16 – 32 mm • Radiusfräser mit stabiler Schneidkante • Einsatz zur Bearbeitung von Formen und Gesenken. • Wirtschaftliche Fräser mit Schraubklemmung. 	
	 B177		ZOHX**	Profile machining of steel, stainless steel and cast iron. Formfräsen von Stahl, rostfreiem Stahl und Grauguss.	<ul style="list-style-type: none"> • Diameter range Ø16-Ø32 • High precision, for finish profile machining. • Two types of chipbreaker, used at different machining condition • High assembling precision, good stability. • Durchmesserbereich: 16-32 mm • Hohe Präzision zur Fertigbearbeitung beim Formfräsen. • 2 Spanbrechergeometrien für unterschiedliche Anwendungen • Hohe Fräserstabilität und Präzision. 	
	Hard alloy toolholder Hartmetall Verlängerung B179					
	Steel toolholder Stahl Verlängerung B180					

Comparison table for milling Insert - Grades
Fräswendepplatten Übersichtstabelle - Sorten

Workpiece material Workpiece material	ISO	Coatet carbide Beschichtetes Hartmetal		Cermet Cermet	Uncoatet carbide unbeschichtetes Hartmetal	PCBN & PCD PCBN & PKD
		CVD	PVD			
P Steel Stahl	P01					
	P10		YBG202	YNG151	YNG151C	
	P20	YBC301 YBC302 YBM251 YBM253	YBG252			
	P30	YBM351 YBC401			YC30S	
	P40		YBG302			
M Stainless Steel Rostfreier Stahl	M01					
	M10	YBM251 YBM253	YBG202 YBG205 YBG252	YNG151	YNG151C	
	M20	YBM351				
	M30		YBG302		YC30S	
	M40					
K Cast iron Grauguss	K01					
	K10	YBD152	YBG102	YNG151	YNG151C	
	K20	YBD252	YBG152			YD201
	K30					
	K40					
N Non-ferrous materials Ne Metalle	N01					
	N10				YD101	
	N20					YD201
	N30					
S Heat-resistant steel Warmfester Stahl	S01					
	S10		YBG202			
	S20	YBM253				
	S30					
H Hardened material Gehärtete Werkstoffe	H01					
	H10					
	H20					
	H30					

Coated Cemented Carbide **CVD** Beschichtetes Hartmetall

Grade Sorte	Coating Beschicht.	Micro-Structure Micro-Struktur	ISO	Application Anwendung
YBC301	Substrate with high strength, in combination with MT-Ti(CN), thin layer Al ₂ O ₃ and TiN Coating. Beschichtetes Hartmetall mit hoher Schneidkanten-sicherheit. In Kombination mit TiCN Al ₂ O ₃ , und TiN.		P15~35	Suitable for light and medium milling of low alloy steel and non alloy steel, even under unfavorable condition. Gut geeignet für leichte bis mittlere Fräsbearbeitung von niedriglegierten Stählen unter schwierigen Bedingungen.
YBC302 New!	Substrate with high strength in combination with CVD coating of MT-Ti(CN) and Al ₂ O ₃ in fine grain size and stable structure. Substrat mit hoher Festigkeit in Kombination mit CVD-beschichtete MT-Ti(CN) und Al ₂ O ₃ in feinkörnigem und stabilem Struktur.		P15~35	High performance in milling of alloy steel and casting steel. Fräsen von legiertem Stahl und Gussstahl mit hoher zerspannleistung.
YBC401	Substrate with excellent toughness, in combination with CVD coating of Ti(CN), thin layer Al ₂ O ₃ , TiN. CVD beschichtetes Hartmetall mit guter Zähigkeit.		P25~50 M20~40	It is suitable for medium to heavy milling steels and stainless steel. Zum Fräsen von Stahl und rostfreiem Stahl in ungünstiger Bearbeitungsbedingung.
YBM251	Substrate with good toughness and strength, in combination with Ti(CN), thin layer Al ₂ O ₃ , TiN. Universal einsetzbare CVD-beschichtete Hartmetallsorte aus TiN +MT-TiCN + dünner Al ₂ O ₃ + TiN mit guter Zähigkeit und Verschleißfestigkeit.		P15~40 M10~30	Good performance in milling of alloy steel and stainless steel. Gute Leistung beim Fräsen von legiertem und rostfreiem Stahl.
YBM253 New!	Carbide substrate with good toughness and strength, in combination with CVD coating of MT-Ti(CN) and Al ₂ O ₃ in fine grain size and stable structure. Hartmetall mit guter Zähigkeit und Festigkeit in Kombination mit CVD beschichtete MT-Ti(CN) und Al ₂ O ₃ in feinkörnigem und stabilem Struktur.		P20~40 M10~30 S10~30	Universal grade for milling of steel, stainless steel and difficult material. Universal einsetzbar Sorte für Fräsen von Stahl, rostfreiem Stahl und schwierige Material.
YBM351	MT-TiCN+Al ₂ O ₃ coated carbide grade with very good strength and impact resistance. Beschichtete Hartmetallsorte MT-TiCN+Al ₂ O ₃ mit ausgezeichneter Widerstandsfähigkeit und Schneidkantensicherheit.		P25~40 M20~40	It is for milling of steel, alloy steel and stainless steel. Zum Fräsen von Stahl, legiertem und rostfreiem Stahl
YBD152	Hard medium grain Substrate in combination with TiCN, thick Al ₂ O ₃ coating. Hartes mittel-feinkörniges Substrat mit TiCN, dicker Al ₂ O ₃ Beschichtung.		K05~25	It is suitable for machining of gray cast iron and nodular cast iron under normal cutting conditions from low to moderate cutting speeds. Bearbeitung von Guss und Kugelgraphitguss mit niedrigen bis mittleren Schnittgeschwindigkeiten.
YBD252	Tough K-substrate in combination with TiN, TiCN, thick Al ₂ O ₃ coating. For milling of cast iron and alloy steel. Zähes K-Substrat mit TiCN, dicke Al ₂ O ₃ Beschichtung.		K15~35	For milling of cast iron and alloy steel. Zum Fräsen von Guss und legiertem Stahl.

B

Milling Tools
Fräser



Coated Cemented Carbide **PVD** Beschichtetes Hartmetall

Grade Sorte	Coating Beschicht.	ISO	Application Anwendung
YBG102	PVD nano-TiAlN coated fine grain hard carbide grade.	K05~K20	For light milling of cast iron, hard steel.
	Nano-TiAlN PVD-beschichtete, feinkörnige Hartmetallsorte.		Zum Schlichtfräsen von Guss und gehärtetem Stahl.
YBG202	PVD nano-TiAlN coated fine grain hard carbide grade. Good performance in combination of toughness and wear resistance.	P10~30	Milling of steel, finishing and semi-finishing of stainless steel, and hightemperature alloys .
		M10~30	
	Nano-TiAlN PVD-beschichtete, feinkörnige Hartmetallsorte. Hervorragende Kombination von Zähigkeit und Verschleißfestigkeit.	S05~20	Zum Fräsen von Stahl, rostfreiem Stahl und warmfesten Superlegierungen bei leichter und mittlerer Bearbeitung.
YBG205	Special PVD nano-TiAlN coated fine grain hard carbide grade. Good performance in combination of toughness and wear resistance.	M10~30	Milling of steel, finishing and semi-finishing of stainless steel.
	Spezielle Nano-TiAlN PVD-beschichtete, feinkörnige Hartmetallsorte. Hervorragende Kombination von Zähigkeit und Verschleißfestigkeit.		Zum Fräsen von rostfreiem Stahl bei leichter und mittlere Bearbeitung
YBG302	Substrate with reasonable hardness and strength + Nano-TiAlN PVD coating	P25~P40	For rough and semi-finish milling of steel and stainless steel.
	Substrate mit guter Härte und Festigkeit + Nano-TiAlN PVD Beschichtung.	M25~40	Anwendung für mittlere und Schruppbearbeitung von Stahl, und rostfreiem Stahl.
YBG152	Substrate with medium hardness and strength + Nano-TiAlN PVD coating	K 20~35	Applicable for rough and semi-finish milling of cast iron.
	Substrate mit mittlerer Härte und Festigkeit + Nano-TiAlN PVD Beschichtung		Anwendung für Schrupp- und mittlere Bearbeitung. von Guss.
YBG252	Ultra fine carbide substrate plus nano-TiAlN PVD coating with high strength, thoughness and wear resistance.	P05~20	Special for finishing of alloy steel, stainless steel and cast iron.
		M05~20	
	Ultra-Feinkorn-Hartmetall plus Nano-TiAlN PVD-Beschichtung mit guter Zähigkeit und Verschleißfestigkeit.	K05~K20	Speziell zum Schlichten von legiertem Stahl, rostfreiem Stahl und Guss.

B

Milling Tools
Fräser

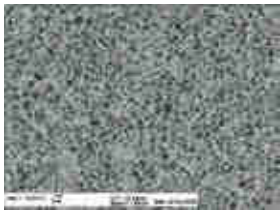
Cermet Cermet

Grade Sorte	Micro-Structure Micro-Struktur	ISO	Application Anwendung
YNG151		P05~20	Applicable for finishing P, M & K ISO Code Anwendung für die Schlichtbearbeitung P,M und K ISO Anwendungsbereich
		M05~20	
		K05~20	
YNG151C		P01~20	Applicable for finish milling P, M and K ISO Code Anwendung für die Schlichtbearbeitung P,M und K ISO Anwendungsbereich
		M01~20	
		K01~20	

Application Anwendung



Machine Maschine	Machining center, dry cutting Bearbeitungscenter, Trockenbearbeitung	Machining center, dry cutting Bearbeitungscenter, Trockenbearbeitung
Workp. material & hardness Werkstückstoff & Härte	45 steel HB 170~220 Stahl	NAK80* HRC42~48
Type of machining Bearbeitung	Face milling finishing Schlichtfräsen	Face milling finishing Schlichtfräsen
Milling tool Fräswerkzeug	FMA03-160-B40-SE12-08	FME03-160-B40-SP12-10
Applicable insert Fräsplatte	YNG151/SEEN1203AFTN	YNG151C/SPEN1203EDER
Cutting data Schnittdaten	Vc=400m/min, fz=0.1mm/z, ap=0.3mm	Vc=420m/min, fz=0.12mm/z, ap=0.35mm

Application results Ergebnis

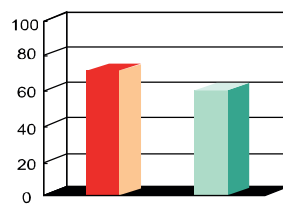

Number of workpiece machined
Anzahl der Werkstücke

■ ZCC-CT ■ Competitor
Wettbewerber

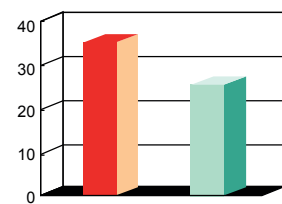

Number of workpiece machined
Anzahl der Werkstücke

■ ZCC-CT ■ Competitor
Wettbewerber

Uncoated Carbide unbeschichtetes Hartmetall

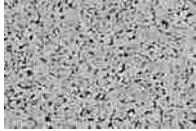
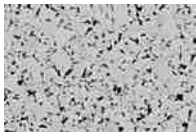
Grade Sorte	Micro-Structure Micro-Struktur	ISO	Application Anwendung
YC30S		P25~40	Applicable for roughing ISO Code P, M
		M25~40	Anwendung für die Schruppbearbeitung ISO Anwendungsbereich P & M.
YD101		N05~25	Applicable for semi-finish and finish milling type ISO Code N. Anwendung für die Mittlere bis Feinbearbeitung ISO Anwendungsbereich N.
YD201		K15~35	Applicable for rough and semi-finish ISO Code K, and for semi-finish ISO Code N.
		N15~30	Anwendung für die mittlere bis Schrupp- Bearbeitung ISO Anwend. K und für die mittlere bearbeitung N ISO Anwendung.

Application Anwendung

Component Werkstück			
Machine Maschine	Verti. machining center, wet machining Vertikales Bearbeitungszentrum, Kühlmittel	Face milling machine, wet machining Planfräsmaschine, Kühlmittel	Face milling machine, dry cutting Planfräsmaschine, Trockenbearbeitung
Workp. material & hardn. Werkstückstoff & Härte	Aluminum alloy HB100 Aluminum Leg.	40CrMnMo HB240	HT250 HB220
Type of machining Bearbeitung	Face milling Planfräser	Face milling Planfräser	Face milling Planfräser
Milling tool Fräswerkzeug	FMA01-100-B32-SE12-07	FMP01-100-B32-TP22-06	FME03-160-B40-SP15-10
Applicable insert Fräsplatte	YD101/SEET12T3-LH	YC30S/TPKN2204PDR	YD201/SPKN1504EDTR
Cutting data Schnittdaten	Vc=300-350m/min, a _p =1-2mm, fz=0.2mm/z	Vc=170m/min, a _p =5-7mm fz=0.3mm/z	Vc=100-130m/min, a _p =7mm, fz=0.35mm/z

Application results Ergebnis

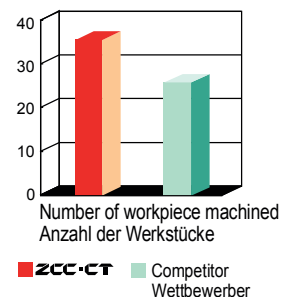
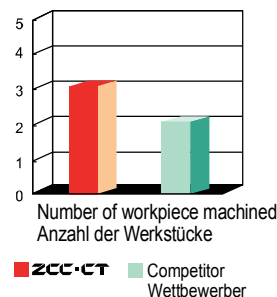
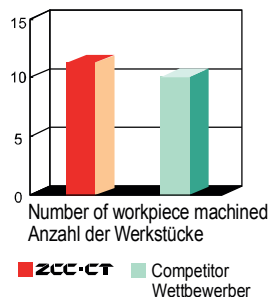

New YBC302

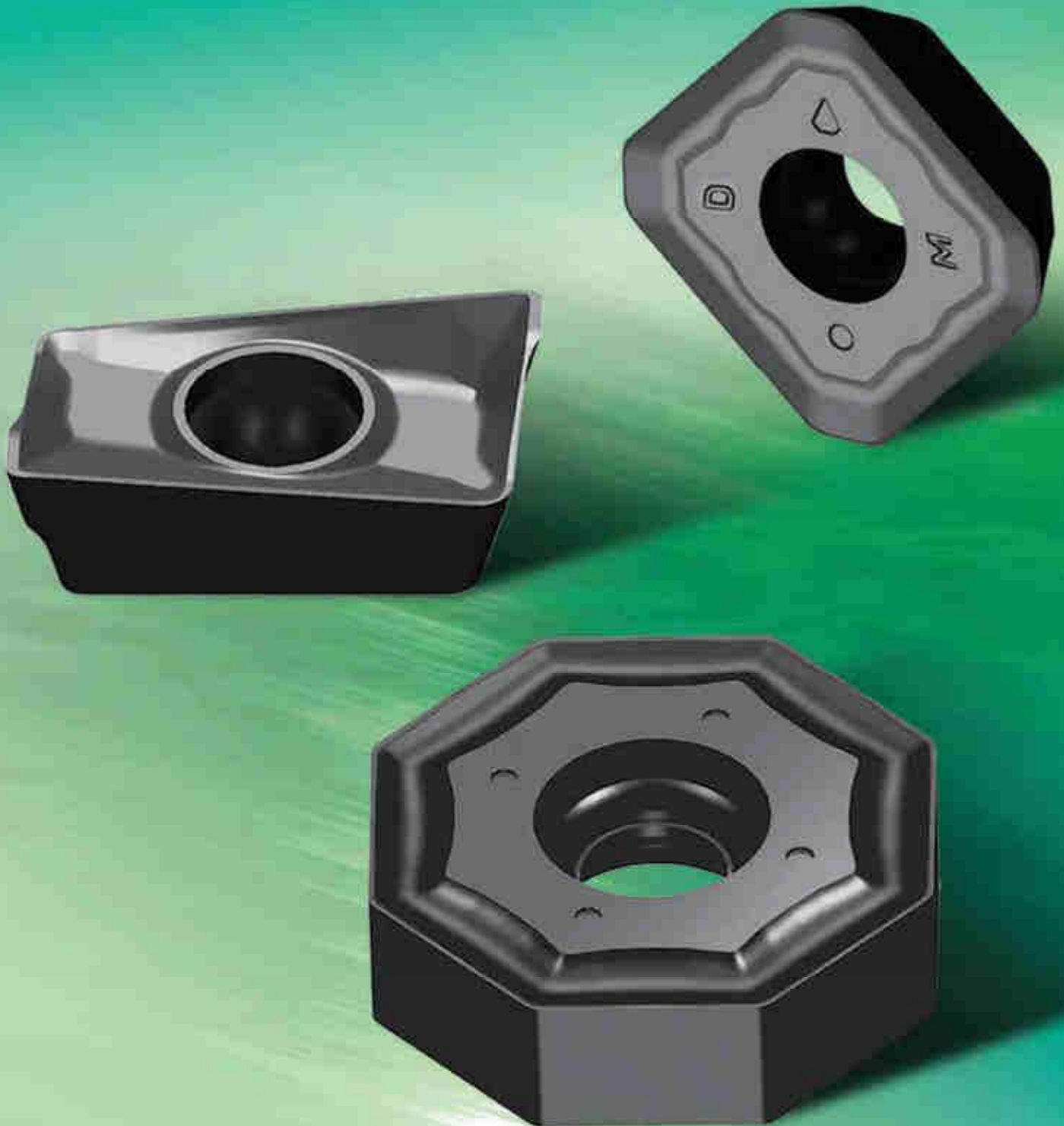

New

Exchangable milling head
Einschraubfräser



QCH

Indexable milling tools code key · Kennzeichnung Fräsen ISO Code

Cutter style Fräser Typ	
FM	Face milling tools Planfräser
EM	Shoulder face milling tools Eck- und Nutenfräser
HM	Helix end milling tools Walzenstirnfräser
SM	Side and face milling tools Scheibenfräser
BM	Profile milling tools Kopierfräser
CM	Chamfering end milling tools Fasfräser
XM	Special milling tools Sonderfräser
TM	

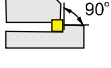
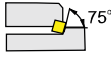
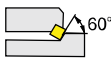
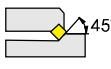
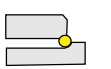
Lead angle Einstellwinkel der Platten		
P	90°	
E	75°	
D	60°	
A	45°	
R		





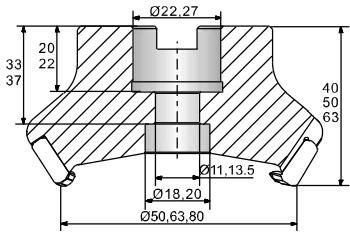
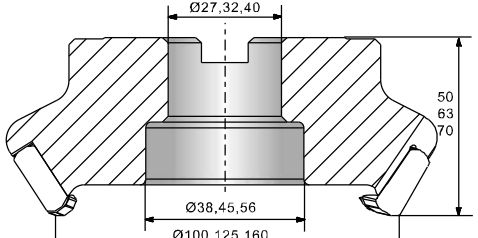
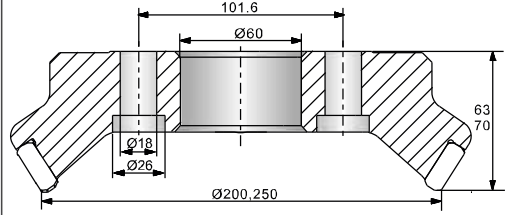
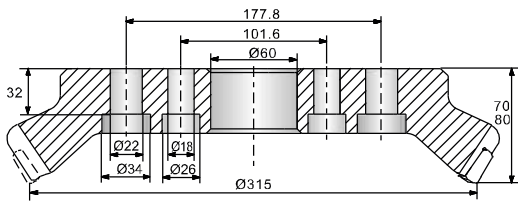



Serial number Serien Nr.
Tool diameter Werkzeug Durchmesser Side and face milling tool : diameter x cutting edge width Plan- und Eckfräser: Durchmesser x WSP-Breite
Coupling size (mm) (as follow figure) Aufnahmetyp

FM E 03 100 - B 32

Structure shape and size of positioning Ausführung und Größe von Werkzeugaufnahme			
A		B	
	Arbor Welle $\varnothing 50\text{-}\varnothing 80$		Arbor Welle $\varnothing 100\text{-}\varnothing 160$
C		D	
	Arbor Welle $\varnothing 200\text{-}\varnothing 250$		Arbor Welle $\varnothing 315$
G	Cylindrical Shank / Zylinderschaft	MW	MW
XP	Weldon / Weldon		

Regarding to the Weldon shank, straight shank and Morse taper shank etc coupling method, please refer to the technical data of tooling systems

Bezüglich der Befestigung beachten Sie bitte die Angabe der Werkzeugaufnahmehersteller.

Insert shape Schneidplattenform	
 C	 D
 R	 S
 T	 L
 H	 O

Insert clearance angle Freiwinkel der Platten	
N	0°
B	5°
C	7°
P	11°
D	15°
E	20°
F	25°

Diameter Durchmesser	Cutting edge length of insert Schneidenlänge					
	Insert Shape Plattenform					
	C	D	R	S	T	L
5.556	—	—	—	—	09	—
6.350	06	07	—	—	11	—
9.525	09	11	09	09	16	—
12.700	12	15	12	12	22	—
15.875	16	19	15	15	27	—
19.050	19	—	19	19	33	—
25.400	25	—	25	25	44	25

S - P 12 - 06 L C

Number of teeth
Anzahl Zähne

Cutting direction
Schnitttrichtung
R= right L=left
R= rechts L= links

With Internal cooling
Mit Innenkühlung

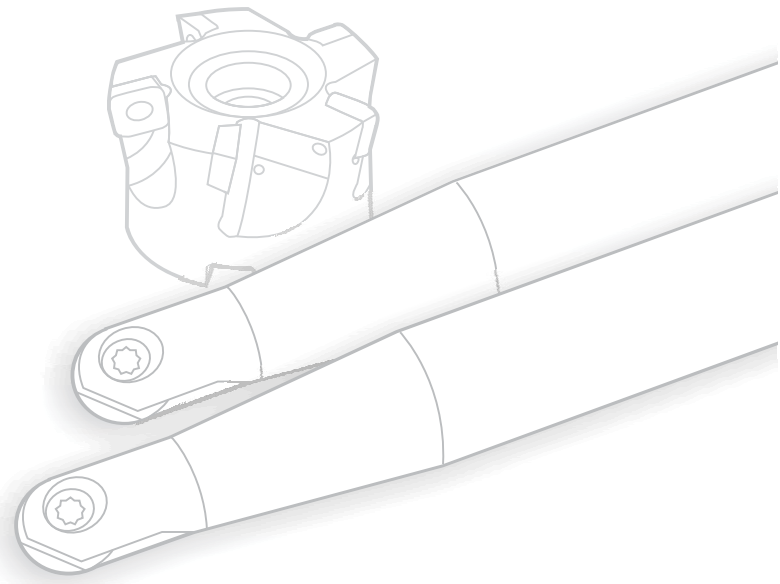
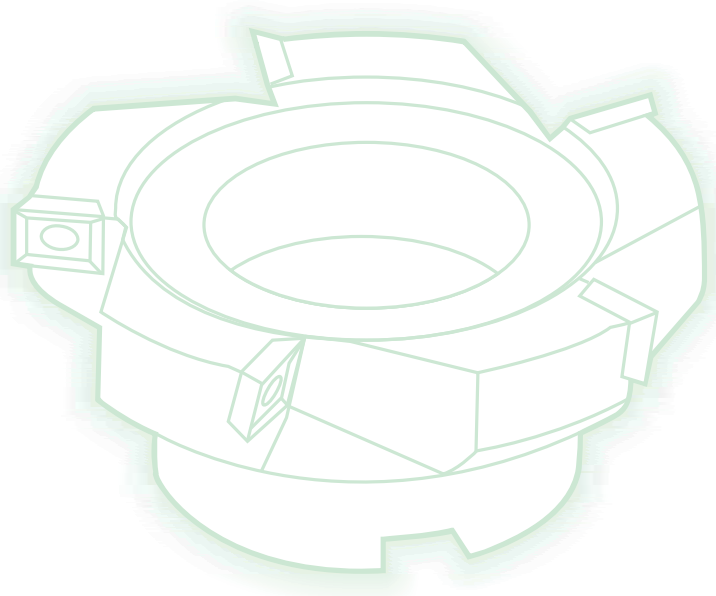

B

Milling Tools
Fräser

Face Milling Tools · Planfräser

Kr:45°



FMA01 P M K N S



Fine pitch
Enge Teilung

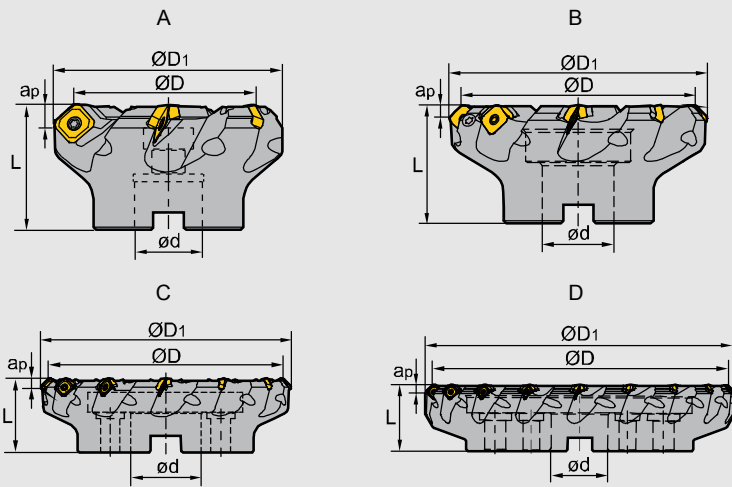

Specification of tools · Werkzeug Beschreibung

Type Typ	Stock Lager	Dimension (mm) Abmessung							No. of teeth Zähne	Coupling Aufnahme	Weight Gewicht (kg)
		R	L	Ø D	Ø D ₁	Ø D	L	ap _{max}			
FMA01											
-050-A22-SE12-04	●	○	50	61	22	40	6	4	A	0.3	
-050-A22-SE12-04C	●	○	50	61	22	40	6	4	A	0.3	
-063-A22-SE12-05	●	○	63	74	22	40	6	5	A	0.5	
-063-A22-SE12-05C	●	○	63	74	22	40	6	5	A	0.5	
-080-A27-SE12-06	●	○	80	91	27	50	6	6	A	1.2	
-080-A27-SE12-06C	●	○	80	91	27	50	6	6	A	1.2	
-100-B32-SE12-07	●	○	100	107	32	50	6	7	B	1.2	
-100-B32-SE12-07C	●	○	100	107	32	50	6	7	B	1.2	
-125-B40-SE12-08	●	○	125	136	40	63	6	8	B	2.6	
-125-B40-SE12-08C	●	○	125	136	40	63	6	8	B	2.6	
-160-B40-SE12-10	●	○	160	170	40	63	6	10	B	4.3	
-160-B40-SE12-10C	○	○	160	170	40	63	6	10	B	4.3	
-200-C60-SE12-12	●	○	200	210	60	63	6	12	C	7.6	
-250-C60-SE12-14	●	○	250	260	60	63	6	14	C	13.5	
-315-D60-SE12-18	●	○	315	325	60	70	6	18	D	20.8	

Spare Parts · Ersatzteile

Diameter Durchmesser Ø D	Screw Schraube	Shim Unterlage	Shim screw Unterlagenschraube	Wrench Schlüssel	Wrench Schlüssel
Ø50 - Ø100	I60M3.5×10	--	--	WT15IS	--
Ø125 - Ø315	I60M3.5×12	S13BS	SM5×7XA		WH35L

● Ex Stock / ab Lager ○ On demand / auf Anfrage

Face Milling Tools · Planfräser

Kr:45°



FMA02 P M K N S



Coarse and differential pitch
Normale und weite Teilung

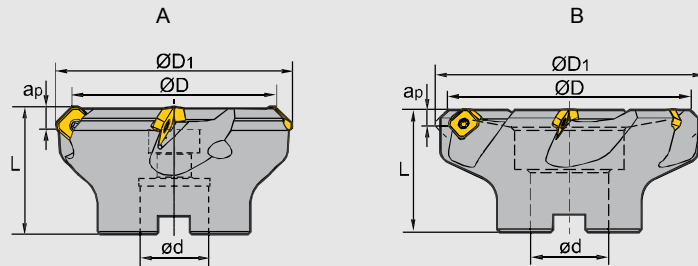

Specification of tools · Werkzeug Beschreibung

Type Typ	Stock Lager		Dimension (mm) Abmessung					No. of teeth Zähne	Coupling Aufnahme	Weight Gewicht (kg)	
	R	L	Ø D	Ø D ₁	Ø D	L	ap _{max}				
FMA02	-050-A22-SE12-03	●	○	50	61	22	40	6	3	A	0.4
	-050-A22-SE12-03C	●	○	50	61	22	40	6	3	A	0.4
	-063-A22-SE12-04	●	○	63	74	22	40	6	4	A	0.6
	-063-A22-SE12-04C	●	○	63	74	22	40	6	4	A	0.6
	-080-A27-SE12-04	●	○	80	91	27	50	6	4	A	1.3
	-080-A27-SE12-04C	●	○	80	91	27	50	6	4	A	1.3
	-100-B32-SE12-05	●	○	100	107	32	50	6	5	B	1.3
	-100-B32-SE12-05C	○	○	100	107	32	50	6	5	B	1.3
	-125-B40-SE12-06	○	○	125	131	40	63	6	6	B	2.6
	-125-B40-SE12-06C	○	○	125	131	40	63	6	6	B	2.6

● Ex Stock / ab Lager ○ On demand / auf Anfrage

Spare Parts · Ersatzteile

Diameter Durchmesser Ø D	Screw Schraube	Wrench Schlüssel
Ø50-Ø125	I60M3.5×10	WT15IS



Applicable tool B11-B18
Werkzeug

Tools code key B26-B27
Werkzeug ISO

Grade selection guide B19-B23
Sortenauswahl

Technical data B215-B220
Technische Daten

Milling · Fräsen

Indexable Milling · Fräswendeplatten

Applicable inserts · Wendschneidplatten

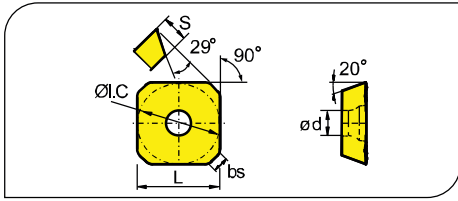

Workpiece Material Werkstoffe	Ideal Machining Condition Gute Bearbeitungsbedingungen		Normal Machining Condition Normale Bearbeitungsbedingungen		Unfavorable Machining Condition Ungünstige Bearbeitungsbedingungen	
	●	●	●	●	●	●
P Steel Stahl	●	●	●	●	●	●
M Stainless Steel Rostfreier Stahl	●	●	●	●	●	●
K Cast iron Gusseisen	●	●	●	●	●	●
N Non-ferrous material Nichte Metalle	●	●	●	●	●	●
S Heat-resistant steel Warmfester Stahl	●	●	●	●	●	●

B

Milling Tools
Fräser

Insert shape Plattenform	Type Typ	Dimension (mm) Abmessung						CVD Coating CVD Beschicht.						PVD Coating PVD Beschicht.						Cermet Cermet	Carbide uncoat. unbe. Hartmetall				
		L	ØI.C	S	ød	bs	R	YBC301	YBC302	YBC401	YBM251	YBM253	YBM351	YBD152	YBD252	YBG102	YBG202	YBG205	YBG302		YBG152	YBG252	YNG151	YNG151C	YC30S
	SEET12T3-DF	13.4	13.4	3.97	4.1	2.55		●	●	●	●	●				●		○			○				
	SEET12T3-CF	13.4	13.4	3.97	4.1	2.55								●		●		○							●
	SEET12T3-EF	13.4	13.4	3.97	4.1	2.55										●		●							
	SEET12T3-DM	13.4	13.4	3.97	4.1	2.55		●	●	●	●	●				●		●							
	SEET12T3-CM	13.4	13.4	3.97	4.1	2.55								●		●		○							○
	SEET12T3-EM	13.4	13.4	3.97	4.1	2.55				●	○	●				●		●							
	SEET12T3-DR	13.4	13.4	3.97	4.1	2.55		●	●			●	●			○		○							
	SEET12T3-CR	13.4	13.4	3.97	4.1	2.55								●	●	○		○							
	SEET12T3-LH	13.4	13.4	3.97	4.1	2.55																		●	●
	SEET12T3-W	17.82	13.4	3.97	4.1	9.46	500				○			○		●		○			○				

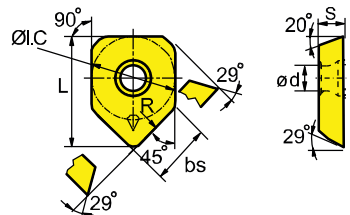

● Ex Stock / ab Lager ○ On demand / auf Anfrage

Chipbreaker Selection for FMA01 · Spanbrecher Auswahl für FMA01

Application Anwendung	Finishing Schlichten	Semi-Finishing Mittlere Bearbeitung	Roughing Schruppen
P	-DF	-DM	-DR
M S	-EF	-EM	
K	-CF	-CM	-CR
N	-LH		

Recommended cutting data · Empfohlene Schnittdaten

Workpiece material Werkstückstoff	Hardness HB Härte	Grade Sorte	Cutting data Schnittdaten			
			V (m/min)	f (mm/z)		
				-DF	-DM	-DR
P	Low-carbon steel Soft steel Niedrig legierter Kohlenstoffstahl Baustahl	YBM251 YBC301	270(220-350)	0.15(0.1-0.2)	0.2 (0.1-0.3)	0.3(0.2-0.4)
		YBG202 YBG205	270(200-360)	0.15(0.1-0.2)	0.2 (0.1-0.3)	0.3(0.2-0.4)
		YBG302	230(180-350)	0.15(0.1-0.2)	0.2 (0.1-0.3)	0.3(0.2-0.4)
		YBM351 YBC401	220(170-300)	0.15(0.1-0.2)	0.2 (0.1-0.3)	0.3(0.2-0.4)
	High-carbon steel Alloy steel Hoch Leg. Kohlenstoffstahl	YBM251 YBC301	240 (200-320)	0.15(0.1-0.2)	0.2 (0.1-0.3)	0.3(0.2-0.4)
		YBG202 YBG205	240 (180-350)	0.15(0.1-0.2)	0.2 (0.1-0.3)	0.3(0.2-0.4)
		YBG302	220 (150-330)	0.15(0.1-0.2)	0.2 (0.1-0.3)	0.3(0.2-0.4)
		YBM351 YBC401	200 (150-280)	0.15(0.1-0.2)	0.2 (0.1-0.3)	0.3(0.2-0.4)
	Alloy tool steel Leg. Werkzeugstahl	YBM251 YBC301 YBD252	220 (180-300)	0.15(0.1-0.2)	0.2 (0.1-0.3)	0.3(0.2-0.4)
		YBG202 YBG205	220 (170-340)	0.15(0.1-0.2)	0.2 (0.1-0.3)	0.3(0.2-0.4)
		YBG302	190 (130-300)	0.15(0.1-0.2)	0.2 (0.1-0.3)	0.3(0.2-0.4)
		YBM351 YBC401	180 (150-250)	0.15(0.1-0.2)	0.2 (0.1-0.3)	0.3(0.2-0.4)
M	Stainless steel Rostfreier Stahl	YBM251	150 (120-240)	0.15(0.1-0.2)	-EM 0.2 (0.1-0.3)	
		YBG202 YBG205	160 (110-270)	0.15(0.1-0.2)	0.2 (0.1-0.3)	
		YBG302	140 (100-250)	0.15(0.1-0.2)	0.2 (0.1-0.3)	
		YBM351 YBC401	140 (100-220)	0.15(0.1-0.2)	0.2 (0.1-0.3)	
K	Cast iron Gusseisen	YBG102	210 (120-300)	0.15(0.1-0.2)	-CF	-CM -CR
		YBD152	240 (180-300)	0.15(0.1-0.2)	0.2 (0.1-0.3)	0.3(0.2-0.4)
N	Al alloy NE-Metalle	YD101	300-	-LH		
		YD201	300-	0.25 (0.1-0.4)		
S	High temperature alloy Hoch warmfeste Leg.	YBG202	40(20-50)	0.1 (0.1-0.2)	-EF	-EM 0.15 (0.1-0.3)

Milling · Fräsen

Indexable Milling Tools · Wendeplattenfräser

Case study for FMA 01 Bearbeitungsbeispiel für FMA 01

Workpiece material: 1Cr18Ni9Ti (HB180)
Werkstückstoff:

Cooling system: dry cutting
Kühlsystem: trocken

Machine: vertical machining center
Maschine: vertikales Maschinen-Center

Cutting data:
Schnittdaten:
Vc=160m/min
ap=1mm
fz=0.2mm/z
ae=60mm

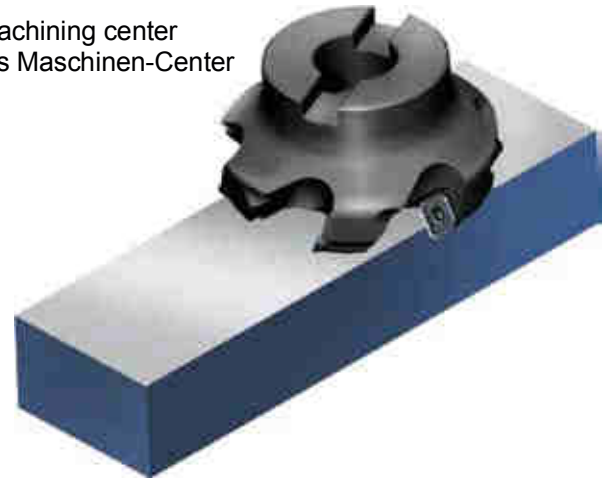

- Tool · Werkzeug : FMR01-080-A27-SE12-06
- Inserts · WSP : SEET12T3-DM/YBG202

Surface roughness of workpiece
Rauhtiefe des Material

ZCC-CT: Ra1.2

Produkt of competitor: Ra1.6
Wettbewerbsprodukt

- Wear comparison of insert.
- Verschleißvergleich der WSP

ZCC-CT

Produkt of competitor
Wettbewerbsprodukt

17'30"

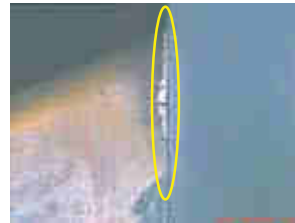

29'30"



33'30"



● Ex Stock / ab Lager ○ On demand / auf Anfrage

Face Milling Tools · Planfräser

Kr:45°



FMA03 P M K

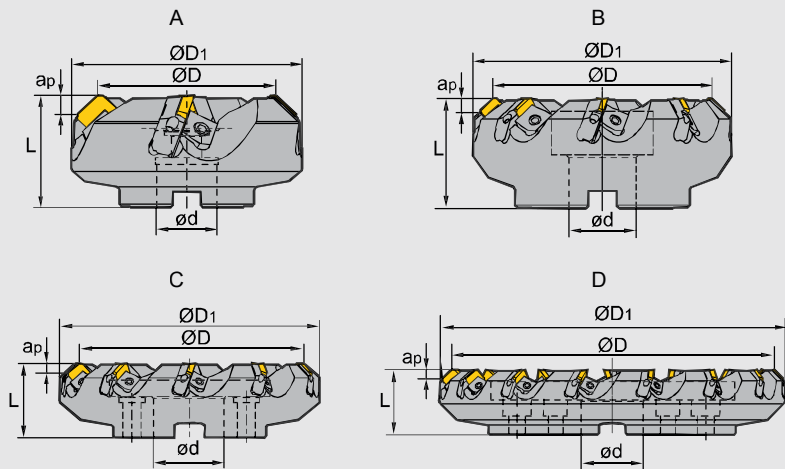

Specification of tools · Werkzeug Beschreibung

Type Typ	Stock Lager	Dimension (mm) Abmessung							No. of teeth Zähne	Coupling Aufnahme	Weight Gewicht (kg)
		R	L	Ø D	Ø D ₁	Ø d	L	ap _{max}			
FMA03											
-080-A27-SE12-04	○ ○			80	103	27	50	5.5	4	A	1.8
-100-B32-SE12-05	○ ○			100	122	32	50	5.5	5	B	2.4
-125-B40-SE12-06	○ ○			125	147	40	63	5.5	6	B	4.4
-160-B40-SE12-08	○ ○			160	181	40	63	5.5	8	B	6.4
-200-C60-SE12-10	○ ○			200	221	60	63	5.5	10	C	8.5
-250-C60-SE12-12	○ ○			250	270	60	63	5.5	12	C	14.1
-315-D60-SE12-15	○ ○			315	353	60	63	5.5	15	D	22.2
-080-A27-SE15-04	○ ○			80	103	27	50	7.5	4	A	1.7
-100-B32-SE15-05	○ ○			100	122	32	50	7.5	5	B	2.3
-125-B40-SE15-06	○ ○			125	147	40	63	7.5	6	B	4.2
-160-B40-SE15-08	○ ○			160	181	40	63	7.5	8	B	6.1
-200-C60-SE15-10	○ ○			200	221	60	63	7.5	10	C	8.3
-250-C60-SE15-12	○ ○			250	270	60	63	7.5	12	C	13.6
-315-D60-SE15-15	○ ○			315	353	60	63	7.5	15	D	21.8

Spare Parts · Ersatzteile

Diameter Durchmesser Ø D	Insert Platte	Cassette Kassette	Wedge Keil	Wedge screw Keilschraube	Locator screw Schraube	Wrench Schlüssel
Ø80-Ø315	SE12	LSE12R/L	W01R/L	DM8×21X	LOM5×15.1	WT20T WH40T
Ø80-Ø315	SE15	LSE15R/L				

● Ex Stock / ab Lager ○ On demand / auf Anfrage

Applicable tool B11-B18
Werkzeug

Tools code key B26-B27
Werkzeug ISO

Grade selection guide B19-B23
Sortenauswahl

Technical data B215-B220
Technische Daten

B

Milling Tools
Fräser

Milling · Fräsen

Indexable Milling · Fräswendeplatten

Applicable inserts · Wendschneidplatten

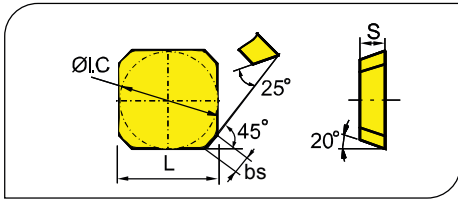

- Ideal Machining Condition
Gute Bearbeitungsbedingungen
- Normal Machining Condition
Normale Bearbeitungsbedingungen
- Unfavorable Machining Condition
Ungünstige Bearbeitungsbedingungen

Workpiece Material Werkstoffe	P	M	K	N	S	YBC301	YBC302	YBC401	YBM251	YBM253	YBM351	YBD152	YBD252	YBG102	YBG202	YBG205	YBG302	YBG152	YBG252	YNG151	YNG151C	YC30S	YD101	YD201	
P Steel Stahl	●	●	●	●	●	●	●	●	●	●	●	●	●	●	●	●	●	●	●	●	●	●	●	●	●
M Stainless Steel Rostfreier Stahl	●	●	●	●	●	●	●	●	●	●	●	●	●	●	●	●	●	●	●	●	●	●	●	●	●
K Cast Iron Gusseisen	●	●	●	●	●	●	●	●	●	●	●	●	●	●	●	●	●	●	●	●	●	●	●	●	●
N Non-ferrous material Nichtmetalle	●	●	●	●	●	●	●	●	●	●	●	●	●	●	●	●	●	●	●	●	●	●	●	●	●
S Heat-resistant steel Wärmebeständiger Stahl	●	●	●	●	●	●	●	●	●	●	●	●	●	●	●	●	●	●	●	●	●	●	●	●	●

Insert shape Plattenform	Type Typ	Dimension (mm) Abmessung				CVD Coating CVD Beschicht.								PVD Coating PVD Beschicht.					Cermets Cermet	Carbide uncoat. unbe. Hartmetall					
		L	I.C	S	bs	YBC301	YBC302	YBC401	YBM251	YBM253	YBM351	YBD152	YBD252	YBG102	YBG202	YBG205	YBG302	YBG152		YBG252	YNG151	YNG151C	YC30S	YD101	YD201
	SEEN1203AFTN	12.7	12.7	3.18	1.8																●				
	SEKN1203AFFN	12.7	12.7	3.18	1.8																				
	SEKN1203AFN	12.7	12.7	3.18	1.8	○																	●	○	
	SEKN1203AFTN	12.7	12.7	3.18	1.8	●			●	●												●	○	●	○
	SEKN1504AFN	15.875	15.875	4.76	1.6	○																		○	○
	SEKN1504AFTN	15.875	15.875	4.76	1.6	●		●	●		●												○		
	SEKR1203AFN	12.7	12.7	3.18	1.8	●		○							●										
	SEKR1504AFN	15.875	15.875	4.76	1.6																				

● Ex Stock / ab Lager ○ On demand / auf Anfrage

Recommended cutting data · Empfohlene Schnittdaten

	Workpiece material Werkstückstoff	Hardness HB Härte	Grade Sorte	Cutting data Schnittdaten	
				V (m/min)	f (mm/z)
P	Low-carbon steel Soft steel Niedriglegierter Kohlenstoffstahl Baustahl	≤180	YNG151	430 (340-500)	0.2 (0.1-0.4)
			YBM251 YBC301	270 (220-350)	0.2 (0.1-0.4)
			YBM351	220 (180-300)	0.25 (0.15-0.3)
			YBG202 YBG205	270 (200-360)	0.2 (0.1-0.3)
			YC30S	140 (100-220)	0.27 (0.1-0.4)
	High-carbon steel Alloy steel Hochleg. Kohlenstoffstahl	180-280	YNG151	400 (320-480)	0.2 (0.1-0.4)
			YBM251 YBC301	240 (200-320)	0.2 (0.1-0.4)
			YBM351	200 (160-280)	0.25 (0.15-0.3)
			YBG202 YBG205	240 (180-350)	0.2 (0.1-0.3)
			YC30S	120 (80-200)	0.27 (0.1-0.4)
	Alloy tool steel Leg. Werkzeugstahl	280-350	YNG151	350 (300-450)	0.2 (0.1-0.4)
			YBM251 YBC301	220 (180-300)	0.2 (0.1-0.4)
			YBM351	180 (150-250)	0.25 (0.15-0.3)
			YBG202 YBG205	220 (170-340)	0.2 (0.1-0.3)
			YC30S	100 (60-180)	0.27 (0.1-0.4)
M	Stainless steel Rostfreier Stahl	≤270	YNG151	220 (160-280)	0.2 (0.1-0.4)
			YBM251	130 (100-220)	0.2 (0.1-0.4)
			YBM351	140 (100-240)	0.25 (0.15-0.3)
			YBG202 YBG205	140 (100-250)	0.2 (0.1-0.3)
			YBG102	210 (120-300)	0.2 (0.1-0.3)
K	Cast iron Gusseisen	180-250	YBD252	200 (150-250)	0.2 (0.1-0.4)
			YD201	100 (80-160)	0.25 (0.1-0.4)

Face Milling Tools · Planfräser

Kr:45°



FMA04 P M K N

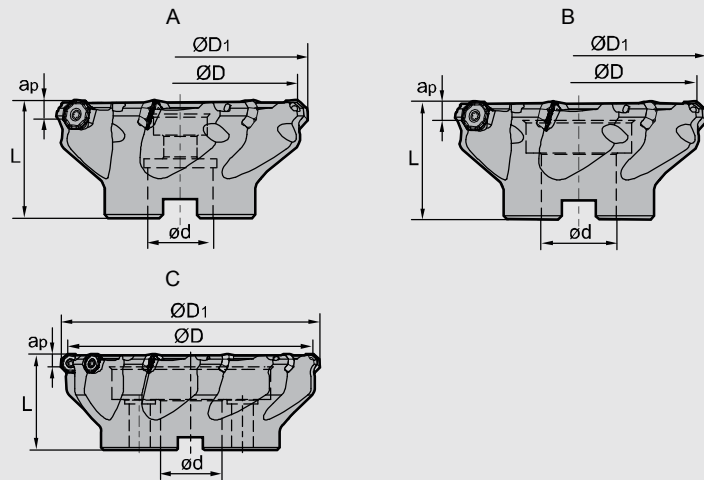

Specification of tools · Werkzeug Beschreibung

Type Typ	Stock Lager		Dimension (mm) Abmessung					No. of teeth Zähne	Coupling Aufnahme	Weight Gewicht (kg)
	R	L	Ø D	Ø D ₁	Ø d	L	ap _{max}			
FMA04 -050-A22-OF05-04	●	○	50	56	22	40	3.5	4	A	0.3
-050-A22-OF05-04C	●	○	50	56	22	40	3.5	4	A	0.3
-050-A22-OF05-05	●	○	50	56	22	40	3.5	5	A	0.4
-050-A22-OF05-05C	●	○	50	56	22	40	3.5	5	A	0.4
-063-A22-OF05-05	●	○	63	69	22	40	3.5	5	A	0.5
-063-A22-OF05-05C	●	○	63	69	22	40	3.5	5	A	0.5
-080-A27-OF05-06	●	○	80	86	27	50	3.5	6	A	0.8
-080-A27-OF05-06C	●	○	80	86	27	50	3.5	6	A	0.8
-100-B32-OF05-07	●	○	100	106	32	50	3.5	7	B	1.2
-100-B32-OF05-07C	●	○	100	106	32	50	3.5	7	B	1.2
-125-B40-OF05-08	●	○	125	130	40	63	3.5	8	B	2.7
-125-B40-OF05-08C	●	○	125	130	40	63	3.5	8	B	2.7
-160-B40-OF05-10	●	○	160	165	40	63	3.5	10	B	5.1

Spare Parts · Ersatzteile

Diameter Durchmesser Ø D	Screw Schraube	Wrench Schlüssel
Ø50-Ø63	I60M4×8.4	WT15IS
Ø80-Ø160	I60M4×10	



● Ex Stock / ab Lager ○ On demand / auf Anfrage

Applicable inserts · Wendeschneidplatten

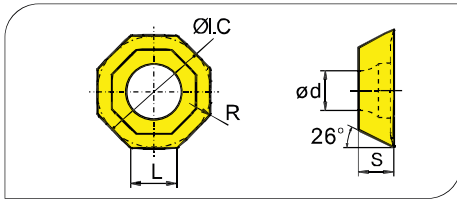

- Ideal Machining Condition / Gute Bearbeitungsbedingungen
- Normal Machining Condition / Normale Bearbeitungsbedingungen
- Unfavorable Machining Condition / Ungünstige Bearbeitungsbedingungen

Workpiece Material / Werkstoffe	P	M	K	N	S	YBC301	YBC302	YBC401	YBM251	YBM253	YBM351	YBD152	YBD252	YBG102	YBG202	YBG205	YBG302	YBG152	YBG252	YNG151	YNG151C	YC30S	YD101	YD201	
P Steel / Stahl	●	●	●	●	●	●	●	●	●	●	●	●	●	●	●	●	●	●	●	●	●	●	●	●	●
M Stainless Steel / Rostfreier Stahl	●	●	●	●	●	●	●	●	●	●	●	●	●	●	●	●	●	●	●	●	●	●	●	●	●
K Cast iron / Gusseisen	●	●	●	●	●	●	●	●	●	●	●	●	●	●	●	●	●	●	●	●	●	●	●	●	●
N Non-ferrous material / Ne Metalle	●	●	●	●	●	●	●	●	●	●	●	●	●	●	●	●	●	●	●	●	●	●	●	●	●
S Heat-resistant steel / Warmfester Stahl	●	●	●	●	●	●	●	●	●	●	●	●	●	●	●	●	●	●	●	●	●	●	●	●	●

Insert shape / Plattenform	Type / Typ	Dimension (mm) / Abmessung					CVD Coating / CVD Beschicht.						PVD Coating / PVD Beschicht.				Cermet / Cermet	Carbide uncoat. / unbe. Hartmetall								
		L	I.C	S	d	R	YBC301	YBC302	YBC401	YBM251	YBM253	YBM351	YBD152	YBD252	YBG102	YBG202	YBG205	YBG302	YBG152	YBG252	YNG151	YNG151C	YC30S	YD101	YD201	
	OFKT05T3-DF	5.26	12.7	3.97	4.4	0.5				○					●	●		○								
	OFKT05T3-DM	5.26	12.7	3.97	4.4	0.5			●			●		●	●	●	●									
	OFKT05T3-LH	5.26	12.7	3.97	4.4	0.5																		●		

Chipbreaker Selection FMA04 · Spanbrecher Auswahl FMA04

Application / Anwendung	Finishing / Schlichten	Semi-Finishing / Mittlere Bearbeitung
P		
M	-DF	-DM
K		
AL	-LH	

Applicable tool / Werkzeug: B11-B18

Tools code key / Werkzeug ISO: B26-B27

Grade selection guide / Sortenauswahl: B19-B23

Technical data / Technische Daten: B215-B220

Milling · Fräsen

Indexable Milling Tools · Wendeplattenfräser

Recommended cutting data · Empfohlene Schnittdaten

Workpiece material Werkstückstoff	Hardness HB Härte	Grade Sorte	Cutting data Schnittdaten			
			V (m/min)	f (mm/z)		
				-DF	-DM	
P Low-carbon steel Soft steel Niedriglegierter Kohlenstoffstahl Baustahl	≤180	YBM251	270 (220-350)	0.2 (0.1-0.3)	0.25 (0.1-0.4)	
		YBG202 YBG205	270 (200-360)	0.2 (0.1-0.3)	0.25 (0.1-0.4)	
		YBM351	220 (180-300)	0.2 (0.1-0.3)	0.25 (0.1-0.4)	
		YBG302	230 (170-350)	0.2 (0.1-0.3)	0.25 (0.1-0.4)	
	High-carbon steel Alloy steel Hochleg. Kohlenstoffstahl	180-280	YBM251	240 (200-320)	0.15 (0.1-0.3)	0.2 (0.1-0.4)
			YBG202 YBG205	240 (180-350)	0.15 (0.1-0.3)	0.2 (0.1-0.4)
			YBM351	200 (160-280)	0.2 (0.1-0.3)	0.25 (0.1-0.4)
			YBG302	220 (150-330)	0.2 (0.1-0.3)	0.25 (0.1-0.4)
	Alloy tool steel Leg. Werkzeugstahl	280-350	YBM251	220 (180-300)	0.15 (0.1-0.3)	0.2 (0.1-0.4)
			YBG202 YBG205	220 (170-340)	0.15 (0.1-0.3)	0.2 (0.1-0.4)
			YBM351	180 (150-250)	0.2 (0.1-0.3)	0.25 (0.1-0.4)
			YBG302	190 (130-300)	0.2 (0.1-0.3)	0.25 (0.1-0.4)
M Stainless steel Rostfreier Stahl	≤270	YBG202 YBG205	160 (110-270)	0.15 (0.1-0.3)	0.2 (0.1-0.4)	
		YBG302	140 (100-250)	0.15 (0.1-0.3)	0.2 (0.1-0.4)	
		YBM251	150 (120-250)	0.15 (0.1-0.3)	0.2 (0.1-0.4)	
K Cast iron Gusseisen	180-250	YBG102	210 (120-300)	0.2 (0.1-0.3)	0.25 (0.1-0.4)	
		YBD152	240 (180-300)	0.2 (0.1-0.3)	0.25 (0.1-0.4)	
				-LH		
N	Al alloy Leg. Alu	-	YD101	300-	0.15 (0.05-0.3)	

B

Milling Tools
Fräser

Case study for FMA04 Bearbeitungsbeispiel für FMA04



- Tool · Werkzeug : FMA04-100-B32-OF05-07
- Inserts · WSP : OFKT05T3-DM/YBG202

Workpiece material
Werkstückstoff: 42CrMo (HB200)
Cooling system: dry cutting
Kühlsystem: trocken

Machine: vertical machining center
Maschine: vertikales Maschinen-Center

Cutting data
Schnittdaten:
Vc=180m/min
ap=1mm
fz=0.2mm/z
ae=60mm

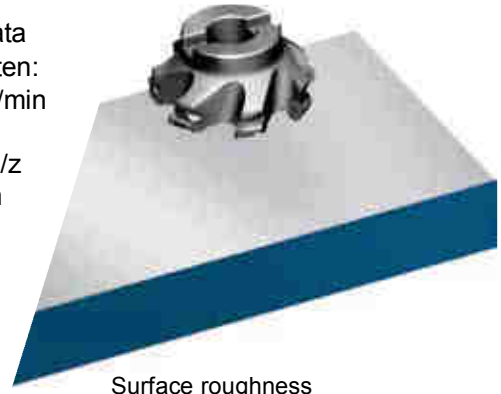

Surface roughness
Rauhtiefe
ZCC-CT: Ra1.2
Wettbewerbsprodukt: **R1.6**

● Wear comparison of insert Verschleißvergleich der WSP

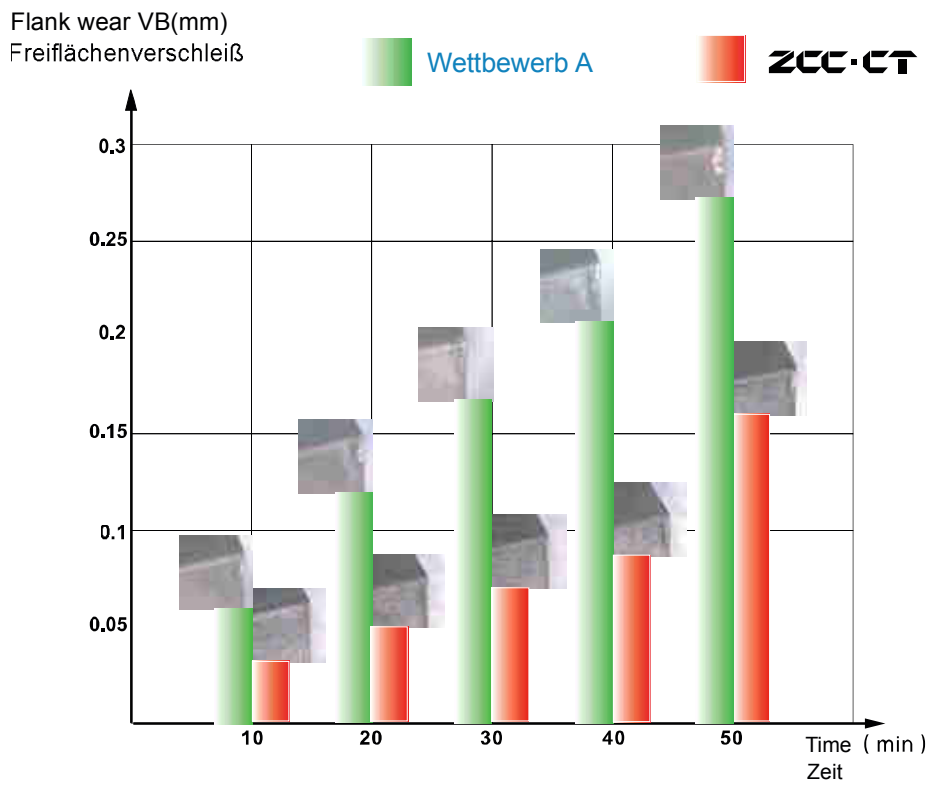

Face Milling Tools · Planfräser

Kr:45°



FMA04 P M K



Wedge
Keil

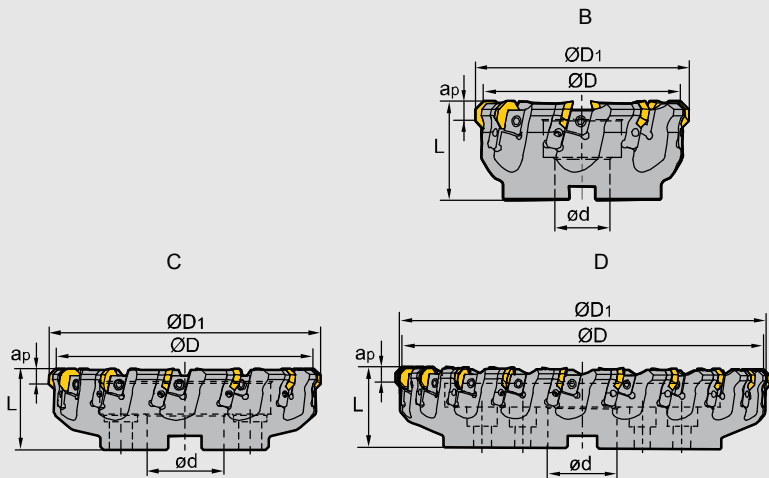

Specification of tools · Werkzeug Beschreibung

Type Typ	Stock Lager	Dimension (mm) Abmessung						No. of teeth Zähne	Coupling Aufnahme	Weight Gewicht (kg)	
		R	L	Ø D	Ø D ₁	Ø d	L				ap _{max}
FMA04		●	○	125	136	40	63	5	8	B	3.9
		●	○	160	171	40	63	5	10	B	5.9
		●	○	200	211	60	63	5	12	C	7.6
		●	○	250	261	60	63	5	16	C	13.3
		○	○	315	321	60	63	5	20	D	20.3

Spare Parts · Ersatzteile

Diameter Durchmesser Ø D	Cassette Kassette	Wedge Keil	Wedge screw Keilschraube	Locator screw Einstellschraube	Wrench Schlüssel	
Ø125-Ø315	LOF07R/L	W02R/L	DM8×21X	LOM5×15.1	WT20T WH40T	

● Ex Stock / ab Lager ○ On demand / auf Anfrage

Applicable inserts · Wendeschneidplatten

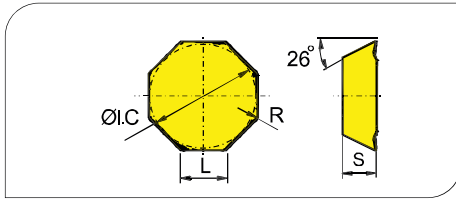

- Ideal Machining Condition / Gute Bearbeitungsbedingungen
- Normal Machining Condition / Normale Bearbeitungsbedingungen
- Unfavorable Machining Condition / Ungünstige Bearbeitungsbedingungen

Workpiece Material / Werkstoffe	P	M	K	N	S	YBC301	YBC302	YBC401	YBM251	YBM253	YBM351	YBD152	YBD252	YBG102	YBG202	YBG205	YBG302	YBG152	YBG252	YNG151	YNG151C	YC30S	YD101	YD201
P Steel / Stahl	●	●	●	●	●	●	●	●	●	●	●	●	●	●	●	●	●	●	●	●	●	●	●	●
M Stainless Steel / Rostfreier Stahl	●	●	●	●	●	●	●	●	●	●	●	●	●	●	●	●	●	●	●	●	●	●	●	●
K Cast iron / Gusseisen	●	●	●	●	●	●	●	●	●	●	●	●	●	●	●	●	●	●	●	●	●	●	●	●
N Non-ferrous material / Ne Metalle	●	●	●	●	●	●	●	●	●	●	●	●	●	●	●	●	●	●	●	●	●	●	●	●
S Heat-resistant steel / Warmfester Stahl	●	●	●	●	●	●	●	●	●	●	●	●	●	●	●	●	●	●	●	●	●	●	●	●

Insert shape / Plattenform	Type / Typ	Dimension (mm) / Abmessung				CVD Coating / CVD Beschicht.								PVD Coating / PVD Beschicht.				Cermets / Cermet	Carbide uncoat. / unbe. Hartmetall						
		L	I.C.	S	R	YBC301	YBC302	YBC401	YBM251	YBM253	YBM351	YBD152	YBD252	YBG102	YBG202	YBG205	YBG302		YBG152	YBG252	YNG151	YNG151C	YC30S	YD101	YD201
	OFKR0704-DF	7.45	17.94	4.76	0.8				○						●										
	OFKR0704-DM	7.45	17.94	4.76	0.8	●	●	●		●	●	●	●	●	○		●								
	OFKR0704 <u>W</u> -DM <i>wiper</i>	7.45	17.94	4.76		○							○		●	●									
	OFKR0704-LH	7.45	19.94	4.76																				○	

Chipbreaker Selection FMA04 · Spanbrecher Auswahl FMA04

Application / Anwendung	Finishing / Schlichten	Semi-Finishing / Mittlere Bearbeitung
P		
M	-DF	-DM
K		
N	LH	LH

Applicable tool / Werkzeug: B11-B18

Tools code key / Werkzeug ISO: B26-B27

Grade selection guide / Sortenauswahl: B19-B23

Technical data / Technische Daten: B215-B220

Recommended cutting data · Empfohlene Schnittdaten

Workpiece material Werkstückstoff	Hardness HB Härte	Grade Sorte	Cutting data Schnittdaten		
			V (m/min)	f (mm/z)	
				-DF	-DM
P Low-carbon steel Soft steel Niedriglegierter Kohlenstoffstahl Baustahl High-carbon steel Alloy steel Hochleg. Kohlenstoffstahl Alloy tool steel Leg. Werkzeugstahl	≤180	YBM251 YBC301	270 (220-350)	0.2 (0.1-0.3)	0.25 (0.1-0.4)
		YBG202 YBG205	270 (200-360)	0.2 (0.1-0.3)	0.25 (0.1-0.4)
		YBM351	220 (180-300)	0.2 (0.1-0.3)	0.25 (0.1-0.4)
		YBG302	230 (170-350)	0.2 (0.1-0.3)	0.25 (0.1-0.4)
	180-280	YBM251 YBC301	240 (200-320)	0.15 (0.1-0.3)	0.2 (0.1-0.4)
		YBG202 YBG205	240 (180-350)	0.15 (0.1-0.3)	0.2 (0.1-0.4)
		YBM351	200 (160-280)	0.2 (0.1-0.3)	0.25 (0.1-0.4)
		YBG302	220 (150-330)	0.2 (0.1-0.3)	0.25 (0.1-0.4)
	280-350	YBM251 YBC301 YBD252	220 (180-300)	0.15 (0.1-0.3)	0.2 (0.1-0.4)
		YBG202 YBG205	220 (170-340)	0.15 (0.1-0.3)	0.2 (0.1-0.4)
		YBM351	180 (150-250)	0.2 (0.1-0.3)	0.25 (0.1-0.4)
		YBG302	190 (130-300)	0.2 (0.1-0.3)	0.25 (0.1-0.4)
M Stainless steel Rostfreier Stahl	≤270	YBG202 YBG205	160 (110-270)	0.15 (0.1-0.3)	0.2 (0.1-0.4)
		YBG302	140 (100-250)	0.15 (0.1-0.3)	0.2 (0.1-0.4)
		YBM251	150 (120-250)	0.15 (0.1-0.3)	0.2 (0.1-0.4)
K Cast iron Gusseisen	180-250	YBG102	210 (120-300)	0.2 (0.1-0.3)	0.25 (0.1-0.4)
		YBD152	240 (180-300)	0.2 (0.1-0.3)	0.25 (0.1-0.4)
		YBD252	200 (150-250)	0.2 (0.1-0.3)	0.25 (0.1-0.4)

B

Milling Tools
Fräser

FMA07

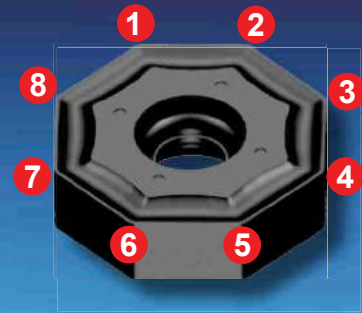

Stable double side insert with 16 cutting edge for high productivity / Stabile doppelseitige Wendeschneidplatte mit 16 Schneidecken für hohe Wirtschaftlichkeit

Positive light cutting chip breaker for finishing to roughing in wide application field / Positive, leicht schneidende Spanbrecherform für die Schlicht- bis Schruppbearbeitung mit weitem Anwendungsspektrum

Cutter body diameter $\varnothing 25$ to $\varnothing 315$, inserts ONHU06**-PM and ONHU08**-PM, Grades YBM253, YBD152, YBM351 and YBG202 / Fräserdurchmesser $\varnothing 25$ bis $\varnothing 315$, WSP ONHU06**-PM und ONHU08**-PM, in den Sorten YBM253, YBD152, YBM351 und YBG202.

Face milling / Planfräser

Kr:45°



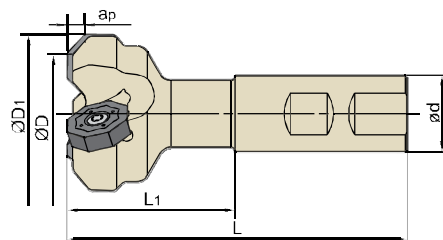

FMA07 P M K



Type Typ	Stock Lager		Dimension Abmessung (mm)						Tooth Zähne Z	Weight Gewicht (kg)	
	R	L	ØD	ØD ₁	ød	L	L ₁	a _{pmax}			
FMA07	-025-XP20-ON06-02	○	○	25	37	20	95	45	4	2	0.2
	-040-XP25-ON06-03	○	○	40	52	25	106	50	4	3	0.4
	-032-XP25-ON08-02	●	○	32	47	25	111	55	5	2	0.4
	-032-XP25-ON08-02C	●	○	32	47	25	111	55	5	2	0.4
	-040-XP25-ON08-03	●	○	40	55	25	111	55	5	3	0.5
	-040-XP25-ON08-03C	●	○	40	55	25	111	55	5	3	0.5
	-050-XP25-ON08-04	●	○	50	65	25	111	55	5	4	0.6

● Ex stock / ab Lager ○ On demand / auf Anfrage

Spare Parts · Ersatzteile

Diameter Durchmesser ØD	Insert WSP	Screw Schraube	Wrench Schlüssel	
				
Ø25 - Ø40	ONHU06**-PF/PM/W	I60M4×10	--	WT15IS
Ø32 - Ø50	ONHU08**-PF/PM/W	I60M5×13	WT20IT	--



Milling · Fräsen

Indexable Milling Tools · Wendeplattenfräser

Face milling / Planfräser

Kr:45°



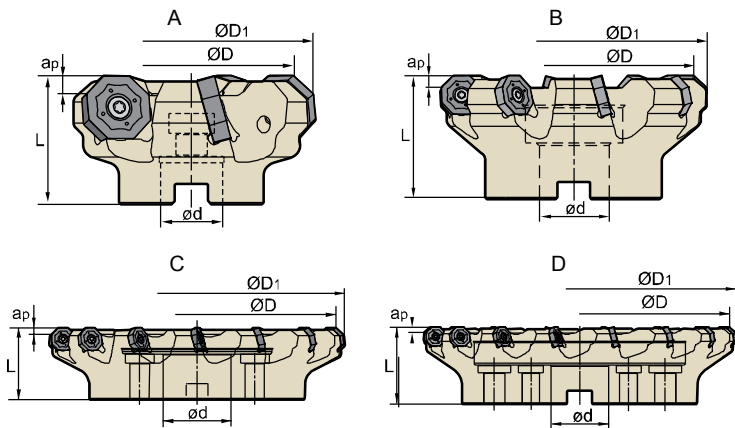

FMA07 P M K



Type Typ	Stock Lager	Dimension Abmessung (mm)						Tooth Zähne Z	Coupling Aufnahme	Weight Gewicht (kg)
		R	L	ØD	ØD1	ød	L			
FMA07	● ○	○	50	62	22	40	4	5	A	0.3
	● ○	○	50	62	22	40	4	5	A	0.3
	● ○	○	63	75	22	40	4	6	A	0.5
	● ○	○	63	75	22	40	4	6	A	0.5
	● ○	○	80	92	27	50	4	7	B	1.0
	● ○	○	80	92	27	50	4	7	B	1.0
	● ○	○	100	112	32	63	4	8	B	1.9
	● ○	○	100	112	32	63	4	8	B	1.9
	● ○	○	125	137	40	63	4	9	B	3.5
	● ○	○	125	137	40	63	4	9	B	3.5
	○ ○	○	160	172	40	63	4	11	C	4.3
	○ ○	○	200	212	60	63	4	13	C	6.4
	○ ○	○	250	262	60	63	4	15	C	13.4
	○ ○	○	315	327	60	80	4	17	D	21.9
	● ○	○	63	78	22	40	5	5	A	0.5
	● ○	○	63	78	22	40	5	5	A	0.5
● ○	○	80	95	27	50	5	6	B	0.9	
● ○	○	80	95	27	50	5	6	B	0.9	
● ○	○	100	115	32	63	5	7	B	1.8	
● ○	○	100	115	32	63	5	8	B	3.1	
● ○	○	125	140	40	63	5	8	B	3.1	
○ ○	○	125	140	40	63	5	8	B	3.1	
● ○	○	160	175	40	63	5	10	C	4.1	
● ○	○	200	215	60	63	5	12	C	6.1	
● ○	○	250	265	60	63	5	14	C	12.0	
● ○	○	315	330	60	80	5	16	D	21.0	

● Ex stock / ab Lager ○ On demand / auf Anfrage

Spare Parts · Ersatzteile

Diameter Durchmesser ØD	Insert WSP	Screw Schraube	Wrench Schlüssel	
				
Ø50 - Ø315	ONHU06** - PF/PM/W	I60M4×10	--	WT15IS
Ø63 - Ø315	ONHU08** - PF/PM/W	I60M5×13	WT20IT	--

● Ex Stock / ab Lager ○ On demand / auf Anfrage

Applicable inserts
Wendeschneidplatten

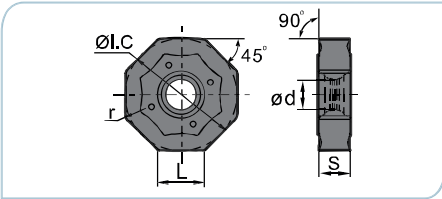

● Ideal Machining Condition
Gute Bearbeitungsbedingungen
● Normal Machining Condition
Normale Bearbeitungsbedingungen
● Unfavorable Machining Condition
Ungünstige Bearbeitungsbedingungen

Workpiece Material Werkstoffe	P	M	K	N	S	1	2	3	4	5	6	7	8	9	10	11	12	13	14	15	16	17	18	19	20
Steel Stahl	●	●	●	●	●	●	●	●	●	●	●	●	●	●	●	●	●	●	●	●	●	●	●	●	●
Stainless Steel Rostfreier Stahl	●	●	●	●	●	●	●	●	●	●	●	●	●	●	●	●	●	●	●	●	●	●	●	●	●
Cast iron Gusseisen	●	●	●	●	●	●	●	●	●	●	●	●	●	●	●	●	●	●	●	●	●	●	●	●	●
Non-ferrite material Nf Metalle	●	●	●	●	●	●	●	●	●	●	●	●	●	●	●	●	●	●	●	●	●	●	●	●	●
Heat-resistant steel Warmfester Stahl	●	●	●	●	●	●	●	●	●	●	●	●	●	●	●	●	●	●	●	●	●	●	●	●	●

Insert WSP	Type Typ	Dimension Abmessung (mm)					CVD Coating CVD Beschicht.					PVD Coating PVD Beschicht.					Cermets Cermet	Carbide uncoat unb. Hartmetall								
		L	ØI.C	S	ød	r	YBC301	YBC302	YBC401	YBM253	YBM351	YBD152	YBD252	YBG102	YBG202	YBG205		YBG302	YBG152	YBG252	YNG151	YNG151C	YC30S	YD101	YD201	
	ONHU060408-PF	6.58	15.875	4.76	4.4	0.83	●							●												
	ONHU08T508-PF	8.39	20.2	5.79	5.3	0.83	●		●		○			●												
	ONHU060408-PM	6.58	15.875	4.76	4.4	0.83	●		●	●	●															
	ONHU08T508-PM	8.39	20.2	5.79	5.3	0.83	●		●	●	●															
	ONHU08T508-W	6.9	20.5	6.00	5.3	0.80					●			○												

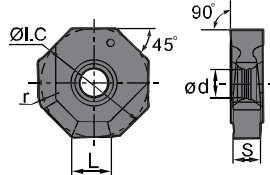

Cutting Data / Schnittdaten

● Ex Stock / ab Lager ○ On demand / auf Anfrage

Workpiece material Werkstück Material	Hardness HB Härte	Grade Sorte	Cutting data · Schnittdaten			
			V _c (m/min)	f _z (mm/z)	a _e (mm)	
					ONHU06**-PM	ONHU08**-PM
P Low-carbon steel Soft steel Niedriglegierter Kohlenstoffstahl Baustahl	≤180	YBG202	270 (220-350)	0.2 (0.1-0.4)	4	5
		YBM253				
		YBM351				
		YBG202				
		YBM253				
High-carbon steel Alloy steel Hochleg. Kohlenstoffstahl Leg. Stahl	180-280	YBM351	240 (180-350)	0.2 (0.1-0.4)	4	5
		YBM253	260 (200-320)	0.2 (0.1-0.4)	4	5
		YBM351	200 (180-280)	0.2 (0.1-0.4)	4	5
Alloy tool steel Leg. Werkzeugstahl	280-350	YBM253	240 (180-300)	0.2 (0.1-0.4)	4	5
		YBM351	180 (150-250)	0.2 (0.1-0.4)	4	5
M Stainless steel Rostfreier Stahl	≤270	YBM253	230(180-300)	0.2(0.1-0.3)	4	5
K Cast iron Gusseisen	180-250	YBD152	270 (150-300)	0.4 (0.1-0.5)	4	5

For Example / Beispiele

Milling Tools / Fräser: FMA07-100-B32-ON08-07
 Insert / WSP: ONHU08T508-PM YBD152
 Parts / Teile: Case of gear pump / Pumpengehäuse
 Workpiece material / Werkstückstoff: HT400
 Cooling system / Kühlsystem: dry cutting / trocken
 Machine / Maschine: CNC floor Type / CNC Maschine
 Cutting data / Schnittdaten: V_c=267m/min f_z=0.42mm/z
 a_p=1.5mm a_e=80mm
 Direction / Richtung: Climb milling / Gleichlaufräsen
 Processing site / Bearbeitungsebene: End face / Planfläche



● Wear comparison of insert
Verschleißvergleich der WSP

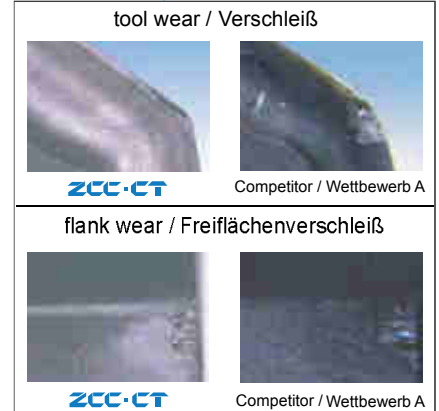

Applicable tool B11-B18
Werkzeug

Tools code key B26-B27
Werkzeug ISO

Grade selection guide B19-B23
Sortenauswahl

Technical data B215-B220
Technische Daten

FMA11

New generation of face milling
with double side insert

Neue Planfräser mit doppelseitiger WSP

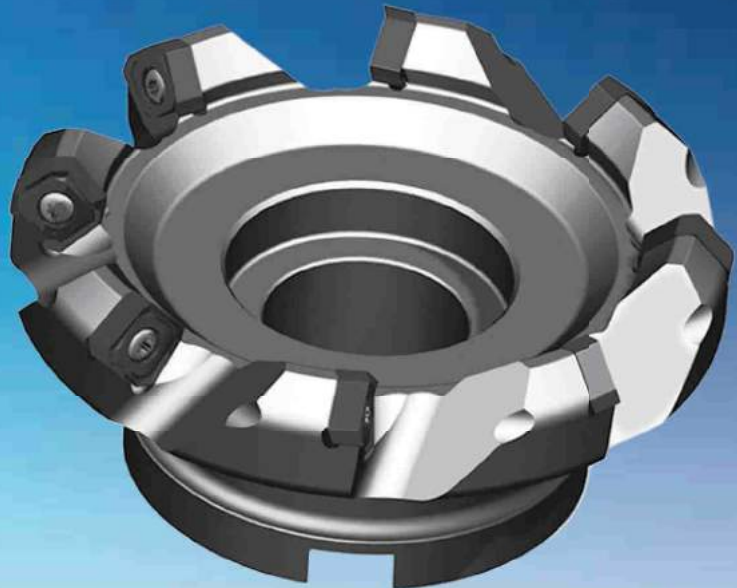

- 8 cutting edge.
- Inserts with big rake angle, reducing power consumption.
- Milling cutter with double negative angle and with thicker inserts for high stability and big cutting depth.
- Inserts with wiper cutting dege for good surface quality.

- 8 Schneidkanten für höhere Auslastung der Wendschneidplatte.
- Großer Spanwinkel für weichen Schnitt.
- Doppelseitige, extra dicke Wendschneidplatte für große Spantiefen bei hoher Bruchsicherheit.
- Wiper Geometrie für beste Oberflächengüte.



Face milling with
double side inserts.

Kr:45°



Face Milling Tools · Planfräser

FMA11 P K

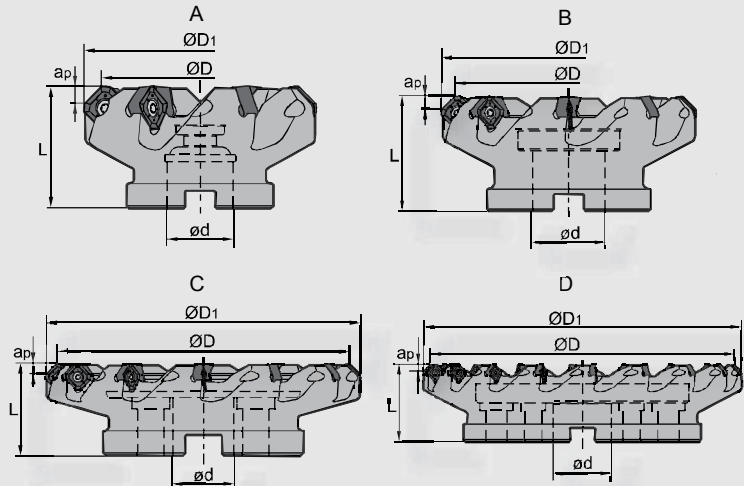

Specification of tools · Werkzeug Beschreibung

Type Typ	Stock Lager	Dimension (mm) Abmessung						No. of teeth Zähne	Coupling Aufnahme	Weight Gewicht (kg)	
		R	L	ØD	ØD ₁	Ød	L				a _{pmax}
FMA11	-063-A22-SN12-05C	●		63	74.47	22	40	5.5	5	A	0.55
	-080-A27-SN12-06C	●		80	91.47	27	50	5.5	6	A	1.14
	-100-B32-SN12-07	●		100	111.47	32	50	5.5	7	B	1.42
	-100-B32-SN12-07C	○		100	111.47	32	50	5.5	7	B	1.42
	-125-B40-SN12-08	●		125	136.47	40	63	5.5	8	B	2.86
	-125-B40-SN12-08C	○		125	136.47	40	63	5.5	8	B	2.86
	-160-C40-SN12-10	●		160	171.47	40	63	5.5	10	C	4.06
FMA11	-063-A22-SN15-05C	●		63	77.4	22	40	7.0	5	A	0.56
	-080-A27-SN15-06C	●		80	94.4	27	50	7.0	6	A	1.06
	-100-B32-SN15-07	●		100	114.4	32	50	7.0	7	B	1.47
	-100-B32-SN15-07C	○		100	114.4	32	50	7.0	7	B	1.47
	-125-B40-SN15-08	●		125	139.4	40	63	7.0	8	B	2.70
	-125-B40-SN15-08C	○		125	139.4	40	63	7.0	8	B	2.70
	-160-C40-SN15-10	●		160	174.4	40	63	7.0	10	C	3.92
	-200-C60-SN15-12	●		200	214.4	60	63	7.0	12	C	5.46
	-250-C60-SN15-14	○		250	264.4	60	63	7.0	14	C	11.26
FMA11	-315-D60-SN15-18	○		315	329.4	60	80	7.0	18	D	20.00
	-125-B40-SN19-07	○		125	142.63	40	63	9.0	7	B	3.00
	-160-C40-SN19-09	○		160	167.63	40	63	9.0	9	C	4.25
	-200-C60-SN19-11	○		200	217.63	60	63	9.0	11	C	6.18
	-250-C60-SN19-13	○		250	267.63	60	63	9.0	13	C	11.55
-315-D60-SN19-16	○		315	332.63	60	80	9.0	16	D	20.90	

Spare Parts · Ersatzteile

Diameter Durchmesser Ø D	Cassette Kassette	Locator screw Keilschraube	Wrench Schlüssel	
Ø63 - Ø160	SNEG1205ANR-GR	DM8×21X	LOM5×15.1	
Ø63 - Ø315	SNEG1506ANR-GR			
Ø125 - Ø315	SNEG1907ANR-GR			

Applicable tool B11-B18
Werkzeug

Tools code key B26-B27
Werkzeug ISO

Grade selection guide B19-B23
Sortenauswahl

Technical data B215-B220
Technische Daten

Milling · Fräsen

Indexable Milling · Fräswendeplatten

Applicable inserts · Wendeschneidplatten

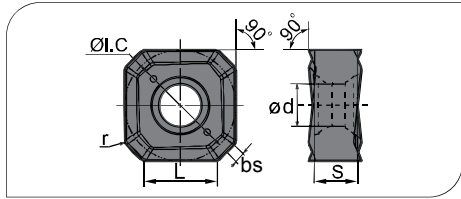

- Ideal Machining Condition / Gute Bearbeitungsbedingungen
- Normal Machining Condition / Normale Bearbeitungsbedingungen
- Unfavorable Machining Condition / Ungünstige Bearbeitungsbedingungen

Workpiece Material / Werkstoffe	P	M	K	N	S	YBC301	YBC302	YBC401	YBM251	YBM253	YBM351	YBD152	YBD252	YBG102	YBG202	YBG205	YBG302	YBG152	YBG252	YNG151	YNG151C	YC30S	YD101	YD201
P Steel / Stahl	●	●	●	●	●	●	●	●	●	●	●	●	●	●	●	●	●	●	●	●	●	●	●	●
M Stainless Steel / Rostfreier Stahl	●	●	●	●	●	●	●	●	●	●	●	●	●	●	●	●	●	●	●	●	●	●	●	●
K Cast Iron / Gusseisen	●	●	●	●	●	●	●	●	●	●	●	●	●	●	●	●	●	●	●	●	●	●	●	●
N Non-ferrous material / Ne Metalle	●	●	●	●	●	●	●	●	●	●	●	●	●	●	●	●	●	●	●	●	●	●	●	●
S Heat-resistant steel / Warmfester Stahl	●	●	●	●	●	●	●	●	●	●	●	●	●	●	●	●	●	●	●	●	●	●	●	●

Insert shape / Plattenform	Type / Typ	Dimension (mm) / Abmessung						CVD Coating / CVD Beschicht.						PVD Coating / PVD Beschicht.						Cermet / Cermet	Carbide uncoat. / unbe. Hartmetall						
		L	I.C.	S	bs	Ød	r	YBC301	YBC302	YBC401	YBM251	YBM253	YBM351	YBD152	YBD252	YBG102	YBG202	YBG205	YBG302		YBG152	YBG252	YNG151	YNG151C	YC30S	YD101	YD201
	SNEG1205ANR-GM	7.6	12.0	4.76	1.05	4.6	0.8	●				●															
	SNEG1506ANR-GM	9.4	15.0	5.54	1.30	5.5	0.9	●				●															
	SNEG1506ANR-GR	9.4	15.0	5.54	1.30	5.5	0.9					●	●														
	SNEG1907ANR-GR	12.1	19.0	7.0	1.67	7.2	1.0					○															

Recommended cutting data · Empfohlene Schnittdaten

Workpiece material / Werkstückstoff	Hardness HB / Härte	Grade / Sorte	Cutting data / Schnittdaten		
			V (m/min)	f (mm/z)	a _{pmax}
P Low-carbon steel / Soft steel / Niedriglegierter Kohlenstoffstahl / Baustahl	≤180	YBM253	270 (220-350)	0.2 (0.1-0.4)	5.5-9.0
		YBC302	270 (220-350)	0.2 (0.1-0.4)	5.5-9.0
	180-280	YBM253	260 (200-320)	0.2 (0.1-0.4)	5.5-9.0
		YBC302	260 (200-320)	0.2 (0.1-0.4)	5.5-9.0
Alloy tool steel / Leg. Werkzeugstahl	280-350	YBM253	240 (180-300)	0.2 (0.1-0.4)	5.5-9.0
		YBC302	240 (180-300)	0.2 (0.1-0.4)	5.5-9.0
K Cast iron / Gusseisen	180-250	YBD152	270 (150-300)	0.4 (0.1-0.5)	5.5-9.0

● Ex Stock / ap Lager ○ On demand / auf Anfrage

FMD02

Rake angle $K_r=67^\circ$
Anstellwinkel $K_r=67^\circ$

Wiper / Wiper

10 Cutting edges
10 Schneidkanten

Screw clamping
Schraubenspannsystem

Clamping by wedge for highest accuracy and reliability.
Klemmkeilspannung für höchste Stabilität und Wiederholgenauigkeit.

Machining of cast iron, $a_{p\ max}=5\text{mm}$
Gussbearbeitung, $a_{p\ max}=5\text{mm}$

Steel. Alloy steel, $a_{p\ max}=7.5\text{mm}$
Stahl. Legierterstahl, $a_{p\ max}=7.5\text{mm}$

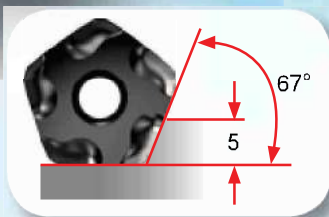

Holder/Halter	FMD02-100-B32-PN11-10 ZCC-CT	Competitor A / Wettbewerb A
Insert/ WSP	PNEG110512R-CR/YBD152	
Cutting data Schnittdaten	D=100mm $a_p=3\sim5\text{mm}$ Vc=243m/min $f_z=0.15\text{mm/Z}$ 145~155 pcs/Stück	D=100mm $a_p=3\sim5\text{mm}$ Vc=243m/min $f_z=0.12\text{mm/Z}$ 120~133 pcs/Stück

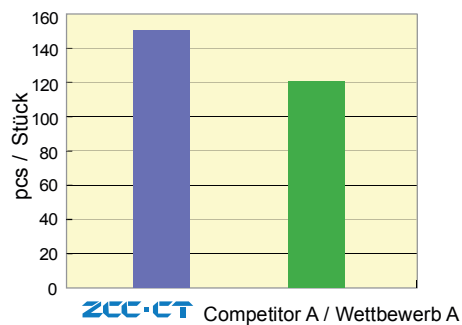

• Comparing of wear / Vergleich



Milling · Fräsen

Indexable Milling Tools · Wendepplattenfräser

Face milling / Planfräser **Kr:67°**



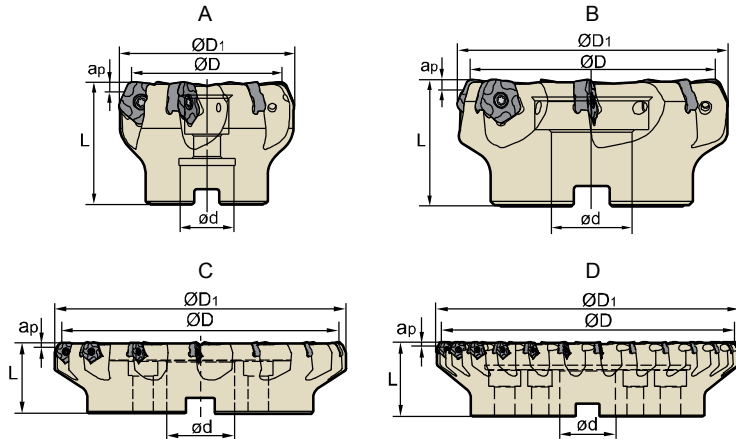

FMD02 **K**



Type Typ	Stock Lager		Dimension Abmessung (mm)						Tooth Zähne Z	Coupling Aufnahme	Weight Gewicht (kg)
	R	L	ØD	ØD ₁	ød	L	a _{pmax}				
FMD02	-050-A22-PN11-04	● ●	50	60.1	22	50	5	4	A	0.6	
	-050-A22-PN11-04C	● ○	50	60.1	22	50	5	4	A	0.6	
	-063-A22-PN11-05	● ○	63	73.1	22	50	5	5	A	0.8	
	-063-A22-PN11-05C	● ○	63	73.1	22	50	5	5	A	0.8	
	-080-A27-PN11-06	● ○	80	90.1	27	50	5	6	A	1.1	
	-080-A27-PN11-06C	● ○	80	90.1	27	50	5	6	A	1.1	
	-100-B32-PN11-07	● ○	100	110.1	32	50	5	7	B	1.8	
	-100-B32-PN11-07C	● ○	100	110.1	32	50	5	7	B	1.8	
	-125-B40-PN11-08	● ○	125	135.1	40	63	5	8	B	2.9	
	-125-B40-PN11-08C	● ○	125	135.1	40	63	5	8	B	2.9	
	-160-B40-PN11-10	● ○	160	170.1	40	63	5	10	B	5.6	
	-200-C60-PN11-12	● ○	200	210.1	60	63	5	12	C	7.9	
-250-C60-PN11-14	● ○	250	260.1	60	63	5	14	C	13.4		
FMD02	-050-A22-PN11-05	● ○	50	60.1	22	50	5	5	A	0.6	
	-050-A22-PN11-05C	● ○	50	60.1	22	50	5	5	A	0.6	
	-063-A22-PN11-06	● ○	63	73.1	22	50	5	6	A	0.9	
	-063-A22-PN11-06C	● ○	63	73.1	22	50	5	6	A	0.9	
	-080-A27-PN11-08	● ○	80	90.1	27	50	5	8	A	1.2	
	-080-A27-PN11-08C	● ○	80	90.1	27	50	5	8	A	1.2	
	-100-B32-PN11-10	● ○	100	110.1	32	50	5	10	B	1.9	
	-100-B32-PN11-10C	● ○	100	110.1	32	50	5	10	B	1.9	
	-125-B40-PN11-12	● ○	125	135.1	40	63	5	12	B	3.2	
	-125-B40-PN11-12C	● ○	125	135.1	40	63	5	12	B	3.2	
	-160-B40-PN11-14	● ○	160	170.1	40	63	5	14	B	6.4	
	-200-C60-PN11-16	● ○	200	210.1	60	63	5	16	C	8.5	
	-200-C60-PN11-20	○ ○	200	210.1	60	63	5	20	C	8.5	
	-250-C60-PN11-18	● ○	250	260.1	60	63	5	18	C	18.0	
-315-D60-PN11-26	● ○	315	325.1	60	80	5	26	D	24.5		

■ Spare Parts · Ersatzteile

ØD	Screw / Schraube	Wrench / Schlüssel	
Ø50 - Ø315	 I60M4×10	 WT15IS	

● Ex Stock / ab Lager ○ On demand / auf Anfrage

Face Milling Tools · Planfräser

Kr:67°



FMD02 K

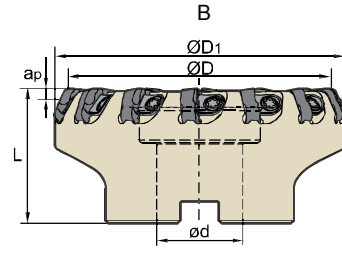
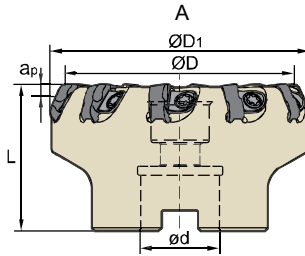



Type Typ	Stock Lager	Dimension Abmessung (mm)						Tooth Zähne Z	Coupling Aufnahme	Weight Gewicht (kg)
		R	L	ØD	ØD1	ød	L			
FMD02	● ○	○	80	90.1	27	50	5	10	A	1.3
	● ○	○	80	90.1	27	50	5	10	A	1.3
	● ○	○	100	110.1	32	50	5	14	B	1.6
	● ○	○	100	110.1	32	50	5	14	B	1.6
	● ○	○	125	135.1	40	63	5	18	B	3.2
	● ○	○	125	135.1	40	63	5	18	B	3.2
	○ ○	○	160	170.1	40	63	5	22	B	5.8
	○ ○	○	200	210.1	60	63	5	28	C	8.5

B

Milling Tools
Fräser

■ Spare Parts · Ersatzteile

ØD	Shim / Unterlage	Screw / Schraube	Wrench / Schlüssel	
Ø80 - Ø160	 W18N	 DM6x20A	 WT15IT	

Applicable tool B11-B18
Werkzeug

Tools code key B26-B27
Werkzeug ISO

Grade selection guide B19-B23
Sortenauswahl

Technical data B215-B220
Technische Daten

Milling - Fräsen

Indexable Milling Tools - Wendeschleiffräser

Applicable inserts Wendeschleifplatten

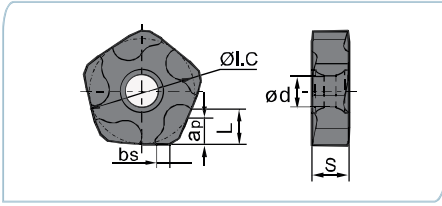

- Ideal Machining Condition
Gute Bearbeitungsbedingungen
- ⊗ Normal Machining Condition
Normale Bearbeitungsbedingungen
- ⊗ Unfavorable Machining Condition
Ungünstige Bearbeitungsbedingungen

Workpiece Material Werkstoff	P Steel Stahl	M Stainless Steel Rostfreier Stahl	K Cast iron Gusseisen	N Non-ferrite material Ne Metalle	S Heat-resistant steel Wärmefester Stahl	YBC301	YBC302	YBC401	YBM251	YBM253	YBM351	YBD152	YBD252	YBG102	YBG202	YBG205	YBG302	YBG152	YBG252	YNG151	YNG151C	YC30S	YD101	YD201	
P	●	●	●	●	●	●	●	●	●	●	●	●	●	●	●	●	●	●	●	●	●	●	●	●	●
M	●	●	●	●	●	●	●	●	●	●	●	●	●	●	●	●	●	●	●	●	●	●	●	●	●
K	●	●	●	●	●	●	●	●	●	●	●	●	●	●	●	●	●	●	●	●	●	●	●	●	●
N	●	●	●	●	●	●	●	●	●	●	●	●	●	●	●	●	●	●	●	●	●	●	●	●	●
S	●	●	●	●	●	●	●	●	●	●	●	●	●	●	●	●	●	●	●	●	●	●	●	●	●

Insert WSP	Type Typ	Dimension Abmessung (mm)						CVD Coating CVD Beschicht.						PVD Coating PVD Beschicht.				Cermet Cermet	Carbide uncoat. unb.Hartmetall								
		L	ØI.C	S	ød	bs	ap	YBC301	YBC302	YBC401	YBM251	YBM253	YBM351	YBD152	YBD252	YBG102	YBG202		YBG205	YBG302	YBG152	YBG252	YNG151	YNG151C	YC30S	YD101	YD201
	PNEG110512R-CF	5.4	15.875	5.56	4.64	1.6	5																				
	PNEG110512L-CF	5.4	15.875	5.56	4.64	1.6	5																				
	PNEG110512R-CM	5.4	15.875	5.56	4.64	1.6	5																				
	PNEG110512L-CM	5.4	15.875	5.56	4.64	1.6	5																				
	PNEG110512R-CR	5.4	15.875	5.56	4.64	1.6	5																				
	PNEG110512L-CR	5.4	15.875	5.56	4.64	1.6	5																				

Applicable inserts Wendeschleifplatten

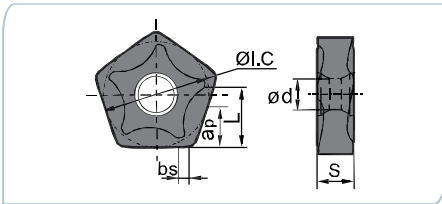

- Ideal Machining Condition
Gute Bearbeitungsbedingungen
- ⊗ Normal Machining Condition
Normale Bearbeitungsbedingungen
- ⊗ Unfavorable Machining Condition
Ungünstige Bearbeitungsbedingungen

Workpiece Material Werkstoff	P Steel Stahl	M Stainless Steel Rostfreier Stahl	K Cast iron Gusseisen	N Non-ferrite material Ne Metalle	S Heat-resistant steel Wärmefester Stahl	YBC301	YBC302	YBC401	YBM251	YBM253	YBM351	YBD152	YBD252	YBG102	YBG202	YBG205	YBG302	YBG152	YBG252	YNG151	YNG151C	YC30S	YD101	YD201	
P	●	●	●	●	●	●	●	●	●	●	●	●	●	●	●	●	●	●	●	●	●	●	●	●	●
M	●	●	●	●	●	●	●	●	●	●	●	●	●	●	●	●	●	●	●	●	●	●	●	●	●
K	●	●	●	●	●	●	●	●	●	●	●	●	●	●	●	●	●	●	●	●	●	●	●	●	●
N	●	●	●	●	●	●	●	●	●	●	●	●	●	●	●	●	●	●	●	●	●	●	●	●	●
S	●	●	●	●	●	●	●	●	●	●	●	●	●	●	●	●	●	●	●	●	●	●	●	●	●

Insert WSP	Type Typ	Dimension Abmessung (mm)						CVD Coating CVD Beschicht.						PVD Coating PVD Beschicht.				Cermet Cermet	Carbide uncoat. unb.Hartmetall								
		L	ØI.C	S	ød	bs	ap	YBC301	YBC302	YBC401	YBM251	YBM253	YBM351	YBD152	YBD252	YBG102	YBG202		YBG205	YBG302	YBG152	YBG252	YNG151	YNG151C	YC30S	YD101	YD201
	PNEG110512R-PF	5.4	15.875	5.56	4.64	1.6	7.5	●																			
	PNEG110512L-PF	5.4	15.875	5.56	4.64	1.6	7.5																				
	PNEG110512R-PM	5.4	15.875	5.56	4.64	1.6	7.5	●																			
	PNEG110512L-PM	5.4	15.875	5.56	4.64	1.6	7.5																				
	PNEG110512R-PR	5.4	15.875	5.56	4.64	1.6	7.5	●																			
	PNEG110512L-PR	5.4	15.875	5.56	4.64	1.6	7.5																				

Cutting Data / Schnittdaten

Workpiece material Werkstück Material	Hardness HB Härte	Grade Sorte	Cutting data / Schnittdaten												
			Vc(m/min)	fz(mm/z)			apmax(mm)								
				PF	PM	PR									
P Low-carbon steel Soft steel Niedriglegierter Kohlenstoffstahl Baustahl	≤180	YBM253 YBC302	270 (220-350)	0.15 (0.1-0.2)	0.2 (0.1-0.3)	0.3 (0.2-0.4)	7.5								
								High-carbon steel Alloy steel Hochleg. Kohlenstoffstahl	180-280	YBM253 YBC302	260 (200-320)	0.15 (0.1-0.2)	0.2 (0.1-0.3)	0.3 (0.2-0.4)	7.5
K Cast iron Gusseisen	180-250	YBD152	270 (150-300)	CF 0.15 (0.1-0.2)	CM 0.2 (0.1-0.3)	CR 0.3 (0.2-0.4)	5								

● Ex Stock / ab Lager ○ On demand / auf Anfrage

Face Milling Tools · Planfräser

Kr:55°



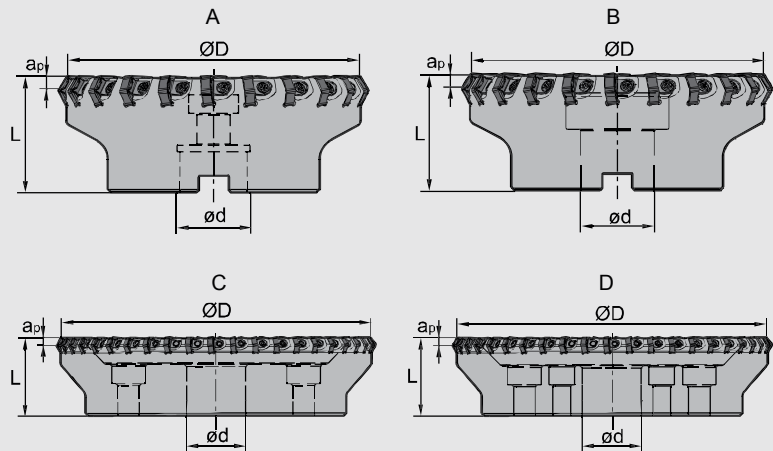

FMD02 K



Specification of tools · Werkzeug Beschreibung

Type Typ	Stock Lager		Dimension (mm) Abmessung				No. of teeth Zähne	Coupling Aufnahme	Weight Gewicht (kg)	
	R	L	ØD	ød	L	apmax				
FMD02	-080-A27-HN09-10	○	○	80	27	50	6	10	A	1.1
	-100-B32-HN09-14	○	○	100	32	63	6	14	B	2.6
	-125-B40-HN09-18	○	○	125	40	70	6	18	B	3.7
	-160-B40-HN09-22	○	○	160	40	63	6	22	B	5.6
	-200-C60-HN09-28	○	○	200	60	63	6	28	C	6.3
	-250-C60-HN09-36	○	○	250	60	63	6	36	C	10.3
	-315-D60-HN09-44	○	○	315	60	63	6	44	D	21.7

Spare Parts · Ersatzteile

Diameter Durchmesser Ø D	Wedge Keil	Wedge screw Keilschraube	Wrench Schlüssel
Ø80-Ø315	 W18N	 DM6×20A	 WT15IT

Applicable tool B11-B18
Werkzeug

Tools code key B26-B27
Werkzeug ISO

Grade selection guide B19-B23
Sortenauswahl

Technical data B215-B220
Technische Daten

B

Milling Tools
Fräser

Milling · Fräsen

Indexable Milling · Fräswendeplatten

Applicable inserts · Wendeschneidplatten

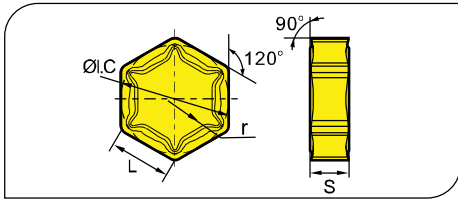

- Ideal Machining Condition / Gute Bearbeitungsbedingungen
- Normal Machining Condition / Normale Bearbeitungsbedingungen
- Unfavorable Machining Condition / Ungünstige Bearbeitungsbedingungen

Workpiece Material / Werkstoffe	P	M	K	N	S
Steel / Stahl	●	●	●	●	●
Stainless Steel / Rostfreier Stahl	●	●	●	●	●
Cast Iron / Gusseisen	●	●	●	●	●
Non-ferrous material / Ne Metalle	●	●	●	●	●
Heat-resistant steel / Warmfester Stahl	●	●	●	●	●

Insert shape / Plattenform	Type / Typ	Dimension (mm) / Abmessung				CVD Coating / CVD Beschicht.						PVD Coating / PVD Beschicht.				Cermet / Cermet	Carbide uncoat. / unbe. Hartmetall								
		L	I.C	S	r	YBC301	YBC302	YBC401	YBM251	YBM253	YBM351	YBD152	YBD252	YBG102	YBG202		YBG205	YBG302	YBG152	YBG252	YNG151	YNG151C	YC30S	YD101	YD201
	HNEX090512-DF	9.16	15.875	5.56	1.2																				
	HNEX090512-DM	9.16	15.875	5.56	1.2																				
	HNEX090512-DR	9.16	15.875	5.56	1.2						●	●													

Chipbreaker Selection FMD02 · Spanbrecher Auswahl FMD02

Application / Anwendung	Finishing / Schlichten	Semi-Finishing / Mittlere Bearbeitung	Roughing / Schruppen
K	-DF	-DM	-DR

Recommended cutting data · Empfohlene Schnittdaten

Workpiece material / Werkstückstoff	Hardness HB / Härte	Grade / Sorte	Cutting data / Schnittdaten			
			V (m/min)	f (mm/z)		
				-DF	-DM	-DR
K Cast iron / Gusseisen	180-250	YBD152	180 (110-250)	0.15(0.1-0.2)	0.2 (0.1-0.3)	0.3(0.2-0.5)
		YBD252	130 (110-200)	0.2(0.1-0.2)	0.25 (0.1-0.3)	0.3(0.2-0.5)

● Ex Stock / ab Lager ○ On demand / auf Anfrage

Face Milling Tools · Planfräser

Kr:60°



FMD03 P M K

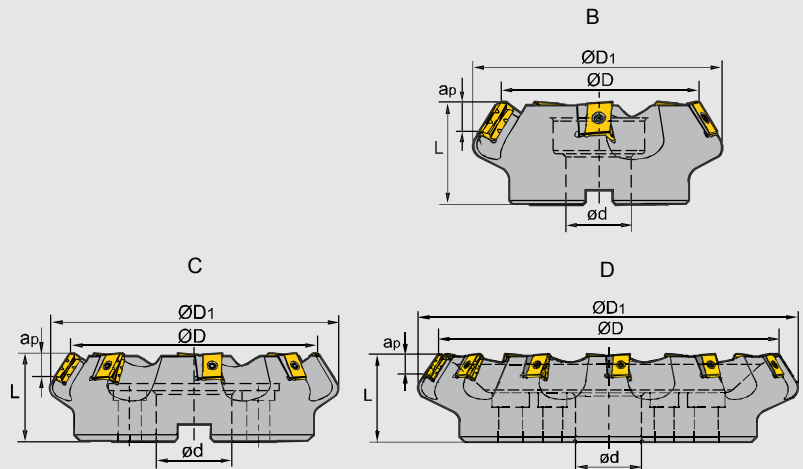

Specification of tools · Werkzeug Beschreibung

Type Typ	Stock Lager	Dimension(mm) Abmessung							No. of Teeth Zähne	Insert WSP	Coupling Aufnahme	Weight Gewicht (kg)
		R	L	ØD	ØD ₁	Ød	L	a _{pmax}				
FMD03	-125-B40-LN20-06	●	○	125	153	40	63	12	6	LNKT2007DN-ZR	B	4.5
	-160-C40-LN20-08	●	○	160	187	40	63	12	8		C	6.9
	-200-C60-LN20-10	●	○	200	227	60	70	12	10		C	10.5
	-250-C60-LN20-12	●	○	250	276	60	70	12	12		C	13.4
	-315-D60-LN20-15	○	○	315	339	60	80	12	15		D	26.2
	-125-B40-LN25-05	○	○	125	154	40	63	16	5	LNKT2510-ZR	B	4.5
	-160-C40-LN25-06	●	○	160	189	40	63	16	6		C	6.9
	-200-C60-LN25-08	●	○	200	229	60	70	16	8		C	10.5
	-250-C60-LN25-10	●	○	250	278	60	70	16	10		C	16.7
	-315-D60-LN25-12	○	○	315	346	60	80	16	12		D	27.3
-400-D60-LN25-16	○	○	400	427	60	80	16	16	D	47.1		

Spare Parts · Ersatzteile

Insert Platte	Cassette Kassette	Wedge screw Plattenschraube	Locator screw Unterlagsschraube	Wrench Schlüssel	
LNKT2007DN-ZR	LLN20R-ZR	I60M4×15	I60M3×7	WT15IS	WT10IS
LNKT2510-ZR	LLN25R-ZR	I60M5×17	I60M3.5×10.4	WT20IT	WT15IS



Applicable tool B11-B18
Werkzeug

Tools code key B26-B27
Werkzeug ISO

Grade selection guide B19-B23
Sortenauswahl

Technical data B215-B220
Technische Daten

Milling · Fräsen

Indexable Milling Tools · Wendepplattenfräser

Applicable inserts · Wendeschneidplatten

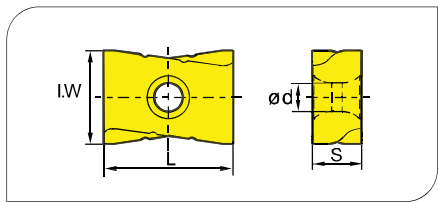

- Ideal Machining Condition / Gute Bearbeitungsbedingungen
- Normal Machining Condition / Normale Bearbeitungsbedingungen
- Unfavorable Machining Condition / Ungünstige Bearbeitungsbedingungen

Workpiece Material / Werkstoff	P	M	K	N	S	YBC301	YBC302	YBC401	YBM251	YBM253	YBM351	YBD152	YBD252	YBG102	YBG202	YBG205	YBG302	YBG152	YBG252	YNG151	YNG151C	YCG305	YD101	YD201
P Steel / Stahl	●	●	●	●	●	●	●	●	●	●	●	●	●	●	●	●	●	●	●	●	●	●	●	●
M Stainless Steel / Rostfreier Stahl	●	●	●	●	●	●	●	●	●	●	●	●	●	●	●	●	●	●	●	●	●	●	●	●
K Cast iron / Gusseisen	●	●	●	●	●	●	●	●	●	●	●	●	●	●	●	●	●	●	●	●	●	●	●	●
N Non-ferrous material / Ne Metalle	●	●	●	●	●	●	●	●	●	●	●	●	●	●	●	●	●	●	●	●	●	●	●	●
S Heat-resistant steel / Warmfester Stahl	●	●	●	●	●	●	●	●	●	●	●	●	●	●	●	●	●	●	●	●	●	●	●	●

Insert shape / Plattenform	Type / Typ	Dimension (mm) / Abmessung				CVD Coating / CVD Beschicht						PVD Coating / PVD Beschicht				Cement / Cemet	Carbide uncoat. / unbe. Hartmetall							
		L	I.W	S	ød	YBC301	YBC302	YBC401	YBM251	YBM253	YBM351	YBD152	YBD252	YBG102	YBG202		YBG205	YBG302	YBG152	YBG252	YNG151	YNG151C	YCG305	YD101
	LNKT2007DN-ZR	20	17	7.94	4.6						●	●					●							
	LNKT2510-ZR	25	18	9.525	5.5						●	●					●							

Recommended cutting data · Empfohlene Schnittdaten

Workpiece material / Werkstückstoff	Hardness HB / Härte	Grade / Sorte	Cutting data / Schnittdaten	
			V (m/min)	f (mm/z)
P Low-carbon steel / Soft steel / Niederlegierter Kohlenstoffstahl / Baustahl	≤180	YBG302	180 (150-300)	0.5 (0.2-0.8)
		YBM351	180 (150-300)	0.5 (0.2-0.8)
	180-280	YBG302	150 (120-280)	0.5 (0.2-0.8)
		YBM351	140 (120-280)	0.5 (0.2-0.8)
	280-350	YBG302	120 (80-250)	0.45 (0.2-0.6)
		YBM351	100 (80-250)	0.45 (0.2-0.6)
M Stainless steel / Rostfreier Stahl	≤270	YBG302	120 (80-200)	0.45 (0.2-0.6)
		YBM351	100 (80-200)	0.45 (0.2-0.6)
K Cast iron / Gusseisen	180-250	YBM351	100 (80-180)	0.5 (0.2-0.8)
		YBD252	130 (110-200)	0.5 (0.2-0.8)

Applicable tool / Werkzeug **B11-B18**

Tools code key / Werkzeug ISO **B26-B27**

Grade selection guide / Sortenauswahl **B19-B23**

Technical data / Technische Daten **B215-B220**

Case study for FMD03 Bearbeitungsbeispiel für FMD03



- Tool · Werkzeug: FMD03-315-D60-LN25-12
- Inserts · WSP: LNKT2510-ZR/YBG302

Workpiece material
Werkstückstoff: ASTMA743 CA-6NM class(HB200)

Cooling system: dry cutting
Kühlsystem: trocken

Machine
Maschine: vertikales Maschinen-Center
NC floor Type · Typ boring and milling machine,
spindle power ≥ 30 KW
Bohr-Fräszentrum Spindelkraft 230 KW

Cutting data
Schnittdaten: $V_c=200$ m/min
 $f_z=0.6$ mm/z
 $a_p=10$ mm



● Wear comparison of insert Verschleißvergleich der WSP

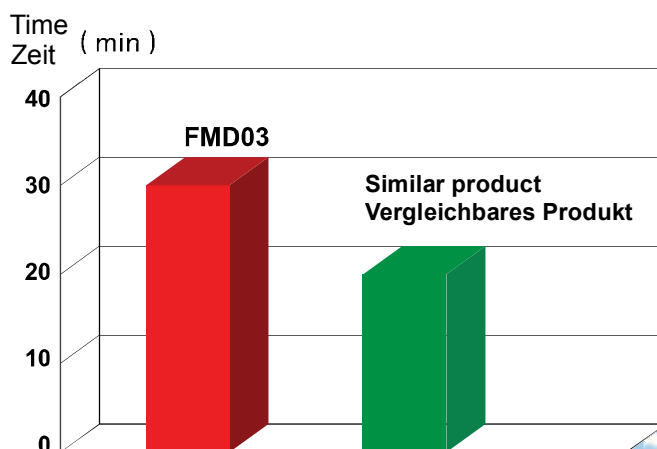

Face Milling Tools · Planfräser

Kr:75°



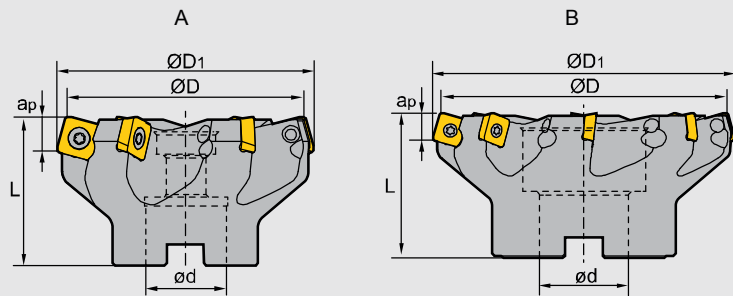

FME02 P M K



Specification of tools · Werkzeug Beschreibung

Type Typ	Stock Lager	Dimension (mm) Abmessung					No. of teeth Zähne	Coupling Aufnahme	Weight Gewicht (kg)
		Ø D	Ø D ₁	Ø d	L	ap _{max}			
FME02	●	50	54	22	40	6	4	A	0.3
	●	63	66	22	50	6	5	A	0.6
	●	80	83	27	50	6	6	A	0.9
	●	100	103	32	50	6	7	B	1.4
	●	125	128	40	63	6	8	B	2.5

Spare Parts · Ersatzteile

Diameter Durchmesser Ø D	Screw Schraube	Wrench Schlüssel
Ø50-Ø125	 I60M5×13.2	 WT20IS



● Ex Stock / ab Lager ○ On demand / auf Anfrage

Applicable inserts · Wendeschneidplatten

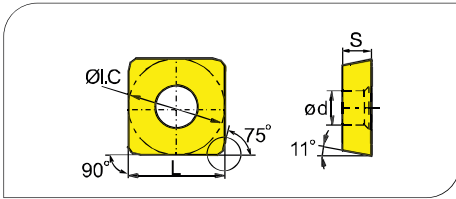

- Ideal Machining Condition / Gute Bearbeitungsbedingungen
- Normal Machining Condition / Normale Bearbeitungsbedingungen
- Unfavorable Machining Condition / Ungünstige Bearbeitungsbedingungen

Workpiece Material / Werkstoffe	P	M	K	N	S	YBC301	YBC302	YBC401	YBM251	YBM253	YBM351	YBD152	YBD252	YBG102	YBG202	YBG205	YBG302	YBG152	YBG252	YNG151	YNG151C	YC30S	YD101	YD201
P Steel / Stahl	●	●	●	●	●	●	●	●	●	●	●	●	●	●	●	●	●	●	●	●	●	●	●	●
M Stainless Steel / Rostfreier Stahl	●	●	●	●	●	●	●	●	●	●	●	●	●	●	●	●	●	●	●	●	●	●	●	●
K Cast iron / Gusseisen	●	●	●	●	●	●	●	●	●	●	●	●	●	●	●	●	●	●	●	●	●	●	●	●
N Non-ferrous material / Ne Metalle	●	●	●	●	●	●	●	●	●	●	●	●	●	●	●	●	●	●	●	●	●	●	●	●
S Heat-resistant steel / Warmfester Stahl	●	●	●	●	●	●	●	●	●	●	●	●	●	●	●	●	●	●	●	●	●	●	●	●

Insert shape / Plattenform	Type / Typ	Dimension (mm) / Abmessung				CVD Coating / CVD Beschicht.				PVD Coating / PVD Beschicht.				Cermets / Cermet	Carbide uncoat. / unbe. Hartmetall										
		L	I.C	S	d	YBC301	YBC302	YBC401	YBM251	YBM253	YBM351	YBD152	YBD252		YBG102	YBG202	YBG205	YBG302	YBG152	YBG252	YNG151	YNG151C	YC30S	YD101	YD201
	SPKW1204EDFR	12.7	12.7	4.76	5.56										●										
	SPKW1204EDSR	12.7	12.7	4.76	5.56										●										
	SPKT1204EDR	12.7	12.7	4.76	5.56										●										

Chipbreaker Selection FME02 · Spanbrecher Auswahl FME02

Application / Anwendung	Finishing / Schlichten	Semi-Finishing / Mittlere Bearbeitung	Roughing / Schruppen
P	EDFR	EDR	EDSR
M	EDFR	EDR	
K	EDFR	EDR	

Recommended cutting data · Empfohlene Schnittdaten

Workpiece material / Werkstückstoff	Hardness HB / Härte	Grade / Sorte	Cutting data / Schnittdaten	
			V (m/min)	f (mm/z)
P Low-carbon steel / Soft steel / Niedriglegierter Kohlenstoffstahl / Baustahl	≤180	YBG202	270 (200-360)	0.2 (0.1-0.3)
	180-280	YBG202	240 (180-350)	0.2 (0.1-0.3)
	280-350	YBG202	220 (170-340)	0.2 (0.1-0.3)
M Stainless steel / Rostfreier Stahl	≤270	YBG202	160 (110-270)	0.2 (0.1-0.3)
K Cast iron / Gusseisen	180-250	YBG202	160 (120-200)	0.2 (0.1-0.3)

Applicable tool / Werkzeug **B11-B18**

Tools code key / Werkzeug ISO **B26-B27**

Grade selection guide / Sortenauswahl **B19-B23**

Technical data / Technische Daten **B215-B220**

Face Milling Tools · Planfräser

Kr:75°



FME03 P M K

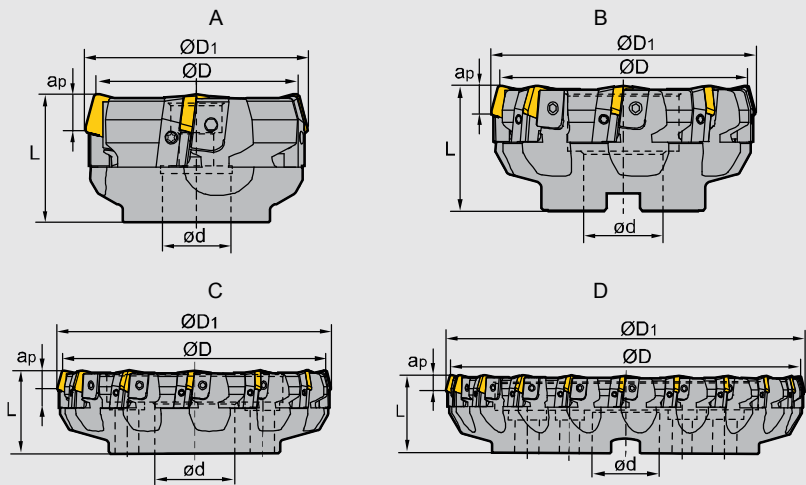

Specification of tools · Werkzeug Beschreibung

Type Typ	Stock Lager		Dimension (mm) Abmessung					No. of teeth Zähne	Coupling Aufnahme	Weight Gewicht (kg)
	R	L	Ø D	Ø D ₁	Ø d	L	ap _{max}			
FME03										
-080-A27-SP12-04	●	○	80	84	27	50	6	4	A	1.1
-100-B32-SP12-06	●	○	100	104	32	50	6	6	B	1.9
-125-B40-SP12-08	○	○	125	129	40	63	6	8	B	3.5
-160-B40-SP12-10	●	○	160	164	40	63	6	10	B	5.7
-200-C60-SP12-12	○	○	200	203	60	63	6	12	C	8.2
-250-C60-SP12-16	○	○	250	253	60	63	6	16	C	13.8
-315-D60-SP12-20	○	○	315	318	60	70	6	20	D	23.5
-080-A27-SP15-04	○	○	80	84	27	50	8	4	A	1.0
-100-B27-SP15-06	○	○	100	104	27	50	8	6	B	1.8
-125-B40-SP15-08	●	○	125	129	40	63	8	8	B	3.3
-160-B40-SP15-10	○	○	160	164	40	63	8	10	B	5.4
-200-C60-SP15-12	○	○	200	204	60	63	8	12	C	7.9
-250-C60-SP15-16	○	○	250	253	60	63	8	16	C	13.6
-315-D60-SP15-20	○	○	315	318	60	70	8	20	D	23.1

Spare Parts · Ersatzteile

Diameter Durchmesser Ø D	Insert Platte	Cassette Kassette	Wedge Keil	Screw Schraube	Locator screw Schraube	Wrench Schlüssel	
Ø80-Ø100	SP12	LSP12R/L	W04R/L	WM8×17	LOM5×15.1	WT20T WT25T	
Ø125-Ø315				WM8×22			
Ø80-Ø315	SP15	LSP15R/L	W04R/L	WM8×22			

● Ex Stock / ab Lager ○ On demand / auf Anfrage

Milling · Fräsen

Indexable Milling · Fräswendeplatten

Applicable inserts · Wendeschneidplatten

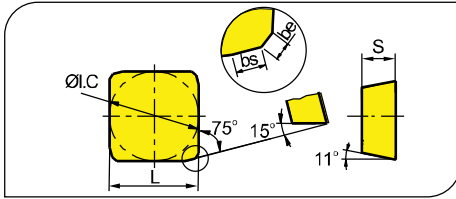

- Ideal Machining Condition
Gute Bearbeitungsbedingungen
- Normal Machining Condition
Normale Bearbeitungsbedingungen
- Unfavorable Machining Condition
Ungünstige Bearbeitungsbedingungen

Workpiece Material Werkstoffe	Steel Stahl	Stainless Steel Rostfreier Stahl	Cast iron Gusseisen	Non-ferite material Ne Metalle	Heat-resistant steel Wärmfester Stahl
P	●●●●●●●●●●	●●●●●●●●●●	●●●●●●●●●●	●●●●●●●●●●	●●●●●●●●●●
M	●●●●●●●●●●	●●●●●●●●●●	●●●●●●●●●●	●●●●●●●●●●	●●●●●●●●●●
K	●●●●●●●●●●	●●●●●●●●●●	●●●●●●●●●●	●●●●●●●●●●	●●●●●●●●●●
N	●●●●●●●●●●	●●●●●●●●●●	●●●●●●●●●●	●●●●●●●●●●	●●●●●●●●●●
S	●●●●●●●●●●	●●●●●●●●●●	●●●●●●●●●●	●●●●●●●●●●	●●●●●●●●●●

Insert WSP	Type Typ	Dimensions (mm) Abmessungen					CVD Coating CVD Beschicht.						PVD Coating PVD Beschicht.					Cermet Cermet	Carbide uncoat. unbe. Hartmetall						
		L	I.C	S	be	bs	YBC301	YBC302	YBC401	YBM251	YBM253	YBM351	YBD152	YBD252	YBG102	YBG202	YBG205		YBG302	YBG152	YBG252	YNG151	YNG151C	YC30S	YD101
	SPKN1203EDER	12.7	12.7	3.18	1	1.4																			
	SPKN1203EDEL	12.7	12.7	3.18	1	1.4																			
	SPKN1203EDFR	12.7	12.7	3.18	1	1.4	○								○								○	●	
	SPKN1203EDFL (SPKN1203EDL)	12.7	12.7	3.18	1	1.4																			●
	SPKN1203EDSKR (SPKN1203EDR)	12.7	12.7	3.18	1	1.4	●	●							●	●	●						○		
	SPKN1203EDSKL (SPKN1203EDL)	12.7	12.7	3.18	1	1.4	●									●								●	
	SPKN1203EDTKR	12.7	12.7	3.18	1	1.4		○				○												●	
	SPKN1203EDTKL	12.7	12.7	3.18	1	1.4																			
	SPKN1203EDS31PR (SPKN1203EDT31R)	12.7	12.7	3.18	1	1.4										○									
	SPKN1203EDS31PL (SPKN1203EDT31L)	12.7	12.7	3.18	1	1.4																			
	SPKR1203EDR-GM	12.7	12.7	3.18	1	1.4				●						○									
	SPKR1203EDL-GM	12.7	12.7	3.18	1	1.4				●						○									
	SPKN1204EDFL (SPKN1204EDL)	12.7	12.7	4.76	1	1.4																			
	SPKN1204EDER (SPKN1204EDR)	12.7	12.7	4.76	1	1.4	●	●															●		
	SPKN1204EDFR	12.7	12.7	4.76	1	1.4																			
	SPKN1204EDSKR	12.7	12.7	4.76	1	1.4							●												
	SPKN1504EDER	15.875	15.875	4.76	1	1.4																			
	SPKN1504EDEL	15.875	15.875	4.76	1	1.4																			
	SPKN1504EDFR	15.875	15.875	4.76	1	1.4																			
	SPKN1504EDFL (SPKN1504EDL)	15.875	15.875	4.76	1	1.4																			
	SPKN1504EDSKR (SPKN1504EDR)	15.875	15.875	4.76	1	1.4	●						●		●	●	●						●		
	SPKN1504EDSKL (SPKN1504EDL)	15.875	15.875	4.76	1	1.4												○					●		
	SPKN1504EDTKR (SPKN1504EDR)	15.875	15.875	4.76	1	1.4									●	●									
	SPKN1504EDTKL	15.875	15.875	4.76	1	1.4																			
	SPKN1504EDS32PR (SPKN1504EDT32R)	15.875	15.875	4.76	1	1.4	○									●									
	SPKN1504EDS32PL (SPKN1504EDTL)	15.875	15.875	4.76	1	1.4																			
SPKN1504EDT32PR (SPKN1504EDTR)	15.875	15.875	4.76	1	1.4	●									○										
SPKN1504EDT32PL (SPKN1504EDTL)	15.875	15.875	4.76	1	1.4																				
	SPKR1904EDFL	19.05	19.05	4.76	1	1.4																			
	SPKR1904EDFR	19.05	19.05	4.76	1	1.4																			
	SPKR1504EDR-GM	19.05	19.05	4.76	1	1.4				●						●									
	SPKR1504EDL-GM	19.05	19.05	4.76	1	1.4				●						●									



B

Milling Tools
Fräser

Milling - Fräsen

Indexable Milling - Fräswendeplatten

Applicable inserts · Wendeschneidplatten

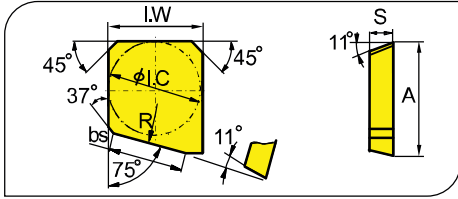

- Ideal Machining Condition
Gute Bearbeitungsbedingungen
- Normal Machining Condition
Normale Bearbeitungsbedingungen
- Unfavorable Machining Condition
Ungünstige Bearbeitungsbedingungen

Workpiece Material Werkstoffe	P	M	K	N	S
Steel Stahl	●	●	●	●	●
Stainless Steel Rostfreier Stahl	●	●	●	●	●
Cast Iron Gusseisen	●	●	●	●	●
Non-ferrous material Nichtmetalle	●	●	●	●	●
Heat-resistant steel Wärmebeständiger Stahl	●	●	●	●	●

Insert shape Plattenform	Type Typ	Dimension (mm) Abmessung						CVD Coating CVD Beschicht.						PVD Coating PVD Beschicht.				Cermet Cermet	Carbide uncoat. unbe. Hartmetall								
		A	I.C	I.W	S	bs	R	YBC301	YBC302	YBC401	YBM251	YBM253	YBM351	YBD152	YBD252	YBG102	YBG202		YBG205	YBG302	YBG152	YBG252	YNG151	YNG151C	YC30S	YD101	YD201
	SPEX1203EDL-1	15	12.7	12.7	3.18	10	500																				○
	SPEX1203EDR-1	15	12.7	12.7	3.18	10	500																				●
	SPEX1504EDL-1	18.2	15.875	15.875	4.76	10	500																				●
	SPEX1504EDR-1	18.2	15.875	15.875	4.76	10	500																				●

Edge preparation for FME03 Schneidkantenausführung für FME03

Edge preparation Schneidkantenausführung	Recommended selection Beschreibung
SP**EDER/L	Honing edge is suitable for semi-finish and finish machining steel and stainless steel. Verrundete Schneidkante für mittlere bis Schlichtbearbeitung von Stahl und rostfreiem Stahl.
SP**EDFR/L	Sharp cutting edge is suitable for finish machining cast iron materials. Scharfe Schneidkante für die Schlichtbearbeitung von Gussmaterial.
SP**EDSKR/L SP**EDS**R/L	After chamfering and honing, the edge has strong capability of anti-breakage, suitable for rough machining steel parts in poor conditions. Gefaste Schneidkante mit Verrundung und guter Stabilität. Für Schruppbearbeitung von Stahl auch bei ungünstigen Verhältnissen.
SP**EDTKR/L SP**EDT**R/L	Chamfering edge is suitable for semi-finish and finish machining steel, stainless steel and cast iron materials. Gefaste Schneide für mittlere bis Schlichtbearbeitung von Stahl und rostfreiem Stahl sowie Guss.
SP**EDR/L-GM	3D chipbreaker to reduce cutting force, reinforce the capability of chip control, improve insert life. Widely applied for semi-finish machining steel, stainless steel and cast iron materials. 3-D Spanbrecher für weniger Schnittkräfte, für gute Spankontrolle und höhere Standzeiten. Großer Anwendungsbereich bei mittlerer Bearbeitung von Stahl, rostfreiem Stahl und Guss.

● Ex Stock / ab Lager ○ On demand / auf Anfrage

Recommended cutting data · Empfohlene Schnittdaten

Workpiece material Werkstückstoff	Hardness HB Härte	Grade Sorte	Cutting data Schnittdaten		
			V (m/min)	f (mm/z)	
P Low-carbon steel Soft steel Niedrig legierter Kohlenstoffstahl Baustahl	≤180	YBG202 YBG205	270(200-360)	0.2 (0.1-0.4)	
		YBG302	230 (170-350)	0.24 (0.1-0.3)	
		YBM251 YBC301	270(220-350)	0.2 (0.1-0.4)	
		YBM351	220 (180-300)	0.25 (0.15-0.3)	
		YC30S	140 (100-220)	0.22 (0.1-0.3)	
	High-carbon steel Alloy steel Hoch Leg. Kohlenstoffstahl	180-280	YBG202 YBG205	240 (180-350)	0.2 (0.1-0.3)
			YBG302	220 (150-330)	0.24 (0.1-0.3)
			YBM251 YBC301	240 (200-320)	0.2 (0.1-0.4)
			YBM351	200 (160-280)	0.25 (0.15-0.3)
			YC30S	120 (80-200)	0.22 (0.1-0.3)
	Alloy tool steel Leg. Werkzeugstahl	280-350	YBG202 YBG205	220 (170-340)	0.2 (0.1-0.3)
			YBG302	190 (130-300)	0.24 (0.1-0.3)
			YBM251 YBC301	220 (180-300)	0.2 (0.1-0.4)
			YBM351	180 (150-250)	0.25 (0.15-0.3)
			YC30S	100 (60-180)	0.22 (0.1-0.3)
M Stainless steel Rostfreier Stahl	≤270	YBG202 YBG205	160 (110-270)	0.2 (0.1-0.3)	
		YBG302	140 (100-250)	0.24 (0.1-0.3)	
		YBM251	150 (120-240)	0.2 (0.1-0.4)	
		YBM351	140 (100-240)	0.25 (0.15-0.3)	
K Cast iron Gusseisen	180-250	YBG102	210 (120-300)	0.12 (0.08-0.3)	
		YBG302	160 (120-200)	0.2 (0.1-0.3)	
		YD201	100 (80-160)	0.24 (0.15-0.4)	

Milling · Fräsen

Indexable Milling Tools · Wendeplattenfräser

Face Milling Tools · Planfräser

Kr:75°



FME04 P M K

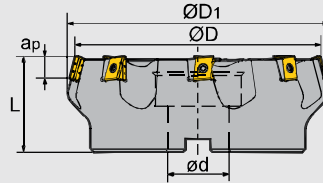

Specification of tools · Werkzeug Beschreibung

Type Typ	Stock Lager	Dimension (mm) Abmessung							No. of teeth Zähne	Coupling Aufnahme	Weight Gewicht (kg)
		R	L	Ø D	Ø D ₁	Ø d	L	apmax			
FME04	-125-B40-LN15-06	●	○	125	137	40	63	10	6	B	3.8
	-160-B40-LN15-08	●	○	160	170	40	63	10	8	C	6.6
	-200-C60-LN15-10	●	○	200	208	60	70	10	10	C	9.6
	-250-C60-LN15-12	○	○	250	257	60	70	10	12	C	13.4
	-315-D60-LN15-16	○	○	315	328	60	80	10	16	D	25.2

Spare Parts · Ersatzteile

Diameter Durchmesser Ø D	Shim Unterlage	Wedge screw Plattenschraube	Locator screw Unterlagsschraube	Wrench Schlüssel
Ø80 Ø100	LLN15-ZR	I60M4×12	I60M3×7	WT15IS
Ø125 ~ Ø315				WT10IS



● Ex Stock / ab Lager ○ On demand / auf Anfrage

Applicable inserts · Wendeschneidplatten

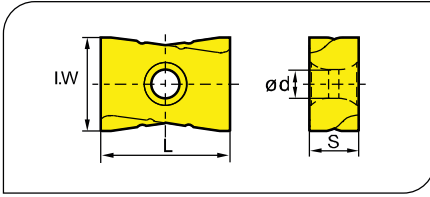

- Ideal Machining Condition / Gute Bearbeitungsbedingungen
- Normal Machining Condition / Normale Bearbeitungsbedingungen
- Unfavorable Machining Condition / Ungünstige Bearbeitungsbedingungen

Workpiece Material / Werkstoff	P	M	K	N	S	YBC301	YBC302	YBC401	YBM251	YBM253	YBM351	YBD152	YBD252	YBG102	YBG202	YBG205	YBG302	YBG152	YBG252	YNG151	YNG151C	YC30S	YD101	YD201	
P Steel / Stahl	●	●	●	●	●	●	●	●	●	●	●	●	●	●	●	●	●	●	●	●	●	●	●	●	●
M Stainless Steel / Rostfreier Stahl	●	●	●	●	●	●	●	●	●	●	●	●	●	●	●	●	●	●	●	●	●	●	●	●	●
K Cast iron / Gusseisen	●	●	●	●	●	●	●	●	●	●	●	●	●	●	●	●	●	●	●	●	●	●	●	●	●
N Non-ferrous material / Ne Metalle	●	●	●	●	●	●	●	●	●	●	●	●	●	●	●	●	●	●	●	●	●	●	●	●	●
S Heat-resistant steel / Warmfester Stahl	●	●	●	●	●	●	●	●	●	●	●	●	●	●	●	●	●	●	●	●	●	●	●	●	●

Insert shape / Plattenform	Type / Typ	Dimension (mm) / Abmessung				CVD Coating / CVD Beschicht.								PVD Coating / PVD Beschicht.				Cermet / Cermet	Carbide uncoat. / unbe. Hartmetall							
		L	I.W	S	d	YBC301	YBC302	YBC401	YBM251	YBM253	YBM351	YBD152	YBD252	YBG102	YBG202	YBG205	YBG302		YBG152	YBG252	YNG151	YNG151C	YC30S	YD101	YD201	
	LNKT1506EN-ZR	15.875	14	6.35	4.6	●			●		●	●	●					●								

Recommended cutting data · Empfohlene Schnittdaten

Workpiece material / Werkstückstoff	Hardness HB / Härte	Grade / Sorte	Cutting data / Schnittdaten	
			V (m/min)	f (mm/z)
P Low-carbon steel / Soft steel / Niedrig legierter Kohlenstoffstahl / Baustahl	≤180	YBG302	180 (150-300)	0.5 (0.2-0.8)
		YBM351	180 (150-300)	0.5 (0.2-0.8)
	180-280	YBG302	150 (120-280)	0.5 (0.2-0.8)
		YBM351	140 (120-280)	0.5 (0.2-0.8)
	280-350	YBG302	120 (80-250)	0.45 (0.2-0.6)
		YBM351	100 (80-250)	0.45 (0.2-0.6)
M Stainless steel / Rostfreier Stahl	≤270	YBG302	120 (80-200)	0.45 (0.2-0.6)
		YBM351	100 (80-200)	0.45 (0.2-0.6)
K Cast iron / Gusseisen	180-250	YBD152	150 (120-200)	0.3 (0.2-0.5)
		YBD252	130 (110-200)	0.3 (0.2-0.5)

B
Milling Tools / Fräser

Face Milling Tools · Planfräser

Kr:90°



FMP01 **P** **M** **K**

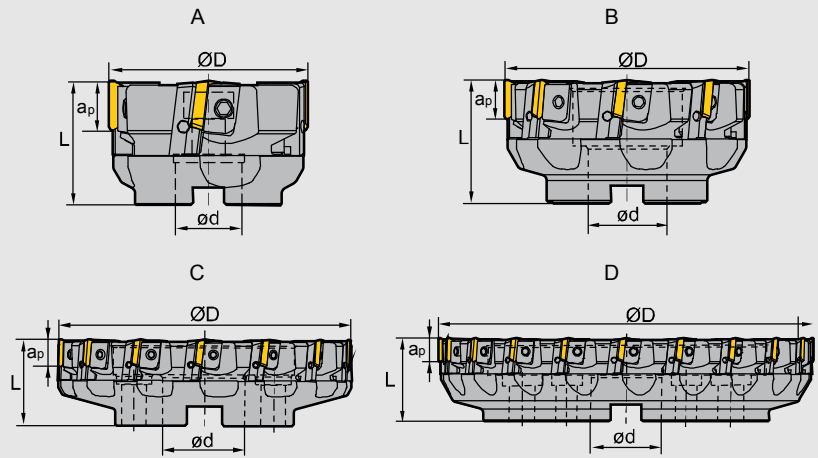

Specification of tools · Werkzeug Beschreibung

Type Typ	Stock Lager		Dimension (mm) Abmessung				No. of teeth Zähne	Coupling Aufnahme	Weight Gewicht (kg)
	R	L	Ø D	Ø d	L	apmax			
FMP01 -080-A27-TP22-04	●	○	80	27	50	18	4	A	1.2
-100-B32-TP22-06	●	○	100	32	50	18	6	B	1.7
-125-B40-TP22-08	●	○	125	40	63	18	8	B	3.2
-160-B40-TP22-10	●	○	160	40	63	18	10	B	5.1
-200-C60-TP22-12	●	○	200	60	63	18	12	C	7.4
-250-C60-TP22-16	○	○	250	60	63	18	16	C	12.3
-315-D60-TP22-20	○	○	315	60	70	18	20	D	21.9

Spare Parts · Ersatzteile

Diameter Durchmesser Ø D	Cassette Kassette	Wedge Keil	Screw Schraube	Locator screw Schraube	Wrench Schlüssel
Ø80 Ø100	LTP4R1/L1	W04R/L	WM8×17	LOM5×15.1	WT20T
Ø125 ~ Ø315	LTP4R/L		WM8×22		WT25T



● Ex Stock / ab Lager ○ On demand / auf Anfrage

Kr:90°



Face Milling Tools · Planfräser

FMP02 P M K

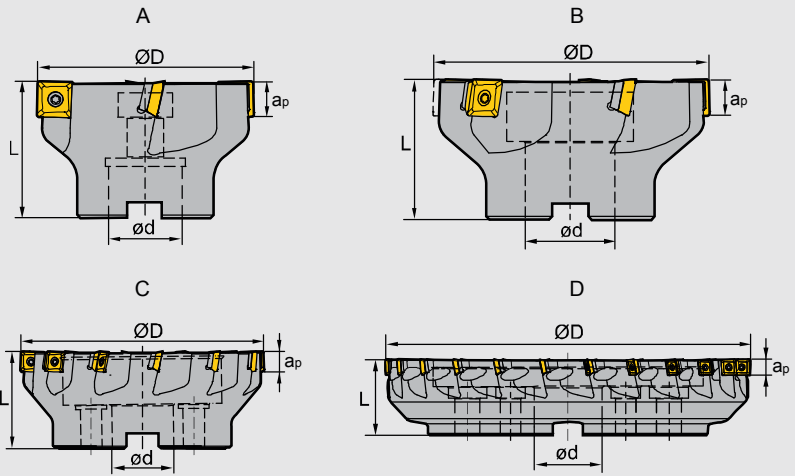

Specification of tools · Werkzeug Beschreibung

Type Typ	Stock Lager	Dimension (mm) Abmessung				No. of teeth Zähne	Coupling Aufnahme	Weight Gewicht (kg)
		Ø D	Ø D	L	apmax			
FMP02								
-050-A22-SE09-05	●	50	22	40	6.7	5	A	0.3
-050-A22-SE09-05C	●	50	22	40	6.7	5	A	0.3
-063-A22-SE09-06	●	63	22	40	6.7	6	A	0.5
-063-A22-SE09-06C	●	63	22	40	6.7	6	A	0.5
-080-A27-SE09-08	●	80	27	50	6.7	8	A	0.9
-080-A27-SE09-08C	●	80	27	50	6.7	8	A	0.9
-100-B32-SE09-08	○	100	32	50	6.7	8	B	1.7
-100-B32-SE09-08C	○	100	32	50	6.7	8	B	1.7
-100-B32-SE09-10	○	100	32	50	6.7	10	B	1.7
-100-B32-SE09-10C	○	100	32	50	6.7	10	B	1.7
-125-B40-SE09-12	○	125	40	63	6.7	12	B	2.6
-125-B40-SE09-12C	○	125	40	63	6.7	12	B	2.6

● Ex Stock / ab Lager ○ On demand / auf Anfrage

■ Specification of tools · Werkzeug Beschreibung

Type Typ	Stock Lager	Dimension (mm) Abmessung				No. of teeth Zähne	Coupling Aufnahme	Weight Gewicht (kg)
		Ø D	Ø D	L	a _{pmax}			
FMP02								
-050-A22-SE12-03	○	50	22	40	10.8	3	A	0.3
-050-A22-SE12-03C	○	50	22	40	10.8	3	A	0.3
-063-A22-SE12-04	○	63	22	40	10.8	4	A	0.4
-063-A22-SE12-04C	○	63	22	40	10.8	4	A	0.4
-080-A27-SE12-04	●	80	27	50	10.8	4	A	0.9
-080-A27-SE12-04C	●	80	27	50	10.8	4	A	0.9
-100-B32-SE12-05	●	100	32	50	10.8	5	B	1.2
-100-B32-SE12-05C	●	100	32	50	10.8	5	B	1.2
-125-B40-SE12-06	○	125	40	63	10.8	6	B	3.1
-125-B40-SE12-06C	○	125	40	63	10.8	6	B	3.1
-160-C40-SE12-08	○	160	40	63	10.8	8	C	4.1
-250-C60-SE12-12	○	250	60	63	10.8	12	C	11.1
-050-A22-SE12-04	●	50	22	40	10.8	4	A	0.3
-050-A22-SE12-04C	●	50	22	40	10.8	4	A	0.3
-063-A22-SE12-05	●	63	22	40	10.8	5	A	0.4
-063-A22-SE12-05C	●	63	22	40	10.8	5	A	0.4
-080-A27-SE12-06	●	80	27	50	10.8	6	A	0.8
-080-A27-SE12-06C	●	80	27	50	10.8	6	A	0.8
-100-B32-SE12-07	●	100	32	50	10.8	7	B	1.2
-100-B32-SE12-07C	●	100	32	50	10.8	7	B	1.2
-125-B40-SE12-08	●	125	40	63	10.8	8	B	3.0
-125-B40-SE12-08C	●	125	40	63	10.8	8	B	3.0
-160-C40-SE12-12	●	160	40	63	10.8	12	C	3.9
-050-A22-SE12-05	●	50	22	40	10.8	5	A	0.2
-050-A22-SE12-05C	●	50	22	40	10.8	5	A	0.2
-063-A22-SE12-06	●	63	22	40	10.8	6	A	0.4
-063-A22-SE12-06C	●	63	22	40	10.8	6	A	0.4
-080-A27-SE12-08	●	80	27	50	10.8	8	A	0.8
-080-A27-SE12-08C	●	80	27	50	10.8	8	A	0.8
-100-B32-SE12-10	●	100	32	50	10.8	10	B	1.2
-100-B32-SE12-10C	●	100	32	50	10.8	10	B	1.2
-125-B40-SE12-12	●	125	40	63	10.8	12	B	2.9
-125-B40-SE12-12C	●	125	40	63	10.8	12	B	2.9
-200-C60-SE12-16	●	200	60	63	10.8	16	C	6.1
-250-C60-SE12-18	●	250	60	63	10.8	18	C	10.9
-315-D60-SE12-24	○	315	60	63	10.8	24	D	21.6

■ Spare Parts · Ersatzteile

Diameter Durchmesser Ø D	Insert Platte	shim Unterlage	Screw Schraube	shim Unterlage Schraube	Wrench Schlüssel	Wrench Schlüssel	
Ø50 ~ Ø125	SE09	--	I60M3×7	--	WT09IS	--	
Ø50	SE12	--	I60M3.5×10	--	WT15IS	--	
Ø63 ~ Ø315		S12BSX	I60M3.5×12	SM5×7XA		WH35L	

Applicable tool B11-B18
Werkzeug

Tools code key B26-B27
Werkzeug ISO

Grade selection guide B19-B23
Sortenauswahl

Technical data B215-B220
Technische Daten

Milling · Fräsen

Indexable Milling · Fräswendepplatten

Applicable inserts · Wendeschneidplatten

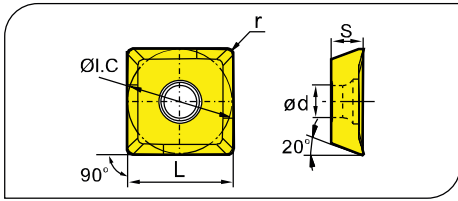

- Ideal Machining Condition / Gute Bearbeitungsbedingungen
- Normal Machining Condition / Normale Bearbeitungsbedingungen
- Unfavorable Machining Condition / Ungünstige Bearbeitungsbedingungen

Workpiece Material / Werkstoffe	P	M	K	N	S
Steel / Stahl	●	●	●	●	●
Stainless Steel / Rostfreier Stahl	●	●	●	●	●
Cast Iron / Guss Eisen	●	●	●	●	●
Non-ferrous material / Ne Metalle	●	●	●	●	●
Heat-resistant steel / Warmfester Stahl	●	●	●	●	●

Insert shape / Plattenform	Type / Typ	Dimension (mm) / Abmessung					CVD Coating / CVD Beschicht.						PVD Coating / PVD Beschicht.					Cermet / Cermet	Carbide uncoat. / unbe. Hartmetall							
		L	I.C.	S	d	r	YBC301	YBC302	YBC401	YBM251	YBM253	YBM351	YBD152	YBD252	YBG102	YBG202	YBG205		YBG302	YBG152	YBG252	YNG151	YNG151C	YC30S	YD101	YD201
	SEET09T308PER-PF	9.525	9.525	4.01	3.3	0.8																				
	SEET09T308PER-PM	9.525	9.525	4.01	3.3	0.8							●													
	SEET09T308PER-PR	9.525	9.525	4.01	3.3	0.8								●												
	SEET120308PER-PF	13.308	13.308	4.04	4.1	0.8	●	●				○														
	SEET120308PER-PM	13.308	13.308	4.04	4.1	0.8		●	●	●	●	●	●	●	●	●	●									
	SEET120308PER-PR	13.308	13.308	4.04	4.1	0.8		●	●	●	●	●	●	○	○	○										
	SEET120308-LH	13.308	13.308	4.04	4.1	0.8									○										●	

Chipbreaker Selection FMP02 · Spanbrecher Auswahl FMP02

Application / Anwendung	Finishing / Schlichten		Semi-Finishing / Mittlere Bearbeitung		Roughing / Schruppen	
P	PF		PM		PR	
M						
K						
N	LH					

● Ex Stock / ab Lager ○ On demand / auf Anfrage

Features of **FMP02** series milling cutters Merkmale des Frässystems

High economical efficiency

Hohe wirtschaftliche Effizienz



FMP02 series square shoulder mills can carry out a variety of cutting operations including face, vertical square shoulder, slot etc. Coarse pitch, fine pitch and extra fine pitch, each has a unique merit. Inserts' chipbreakers and grades are applied and optimized for a long tool life, they can achieve high efficiency machining in different condition. Each insert has 4 cutting edge, high economical efficiency.

Das universelle Frässystem FMP02 wird für unterschiedliche Fräsoperationen eingesetzt, z.B. Planfräsen, Eckfräsen, Nutenfräsen etc. Fräser mit weiter, enger und extraenger Teilung, Wendeschneidplatten in verschiedenen Sorten und Spanbrechern ermöglichen eine optimale Bearbeitung mit hoher Wirtschaftlichkeit; jede Wendeschneidplatte hat 4 Schneidkanten.

High productivity
Hohe Produktivität

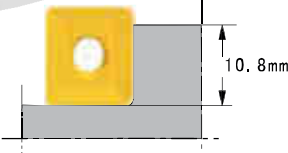

The major cutting edge is a α -curve, therefore the S Type inserts makes the tool obtain a ideal 90° approach angle while the minor cutting edge angle is enough. It ensures stable cutting operation. The maximum cutting depth can reach 10.8 mm, and the maximum feed rate can reach 0.3mm/z

Die Hauptschneide ist wellenförmig ausgebildet, erzielt einen idealen 90 Grad Einstellwinkel und eine stabile Bearbeitung. Die maximale Schnitttiefe beträgt 10,8 mm bei einem maximalen Vorschub von 0,3 mm/z.

Special structure design and fine manufacture make the tools possess very high precision, greatly improve the workpiece precision and surface quality.

Die spezielle Konstruktion und die präzise Herstellung der Schneidplatte garantieren eine verbesserte Genauigkeit und Oberfläche des Werkstückes.

High precision
Hohe Präzision

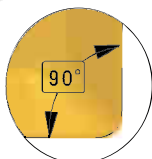

Large positive rake angle design makes cutting light and fast.

Großer positiver Spanwinkel für leichte und schnelle Bearbeitung.

Less cutting force
Geringe Schnittkräfte

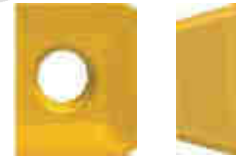

Simple screw clamping, inserts displacement is convenient. The chip pocket of rake face is big enough for smooth chip removal.

Durch die Schraubenklammerung ist einfacher Schneiden- bzw. Schneidplattenwechsel gegeben.

Easy & convenient to apply
Einfacher & schneller Schneidenwechsel

Adopting the carbide shim machined precisely to protect tool body, enable tool durable and long life.

Die präzise Hartmetall-Zwischenlage schützt den Fräskörper und bringt eine hohe Werkzeuglebensdauer.

High reliability
Hohe Werkzeugstabilität & Sicherheit



Milling · Fräsen

Indexable Milling Tools · Wendeplattenfräser

Recommended cutting data · Empfohlene Schnittdaten

Workpiece material Werkstückstoff	Hardness HB Härte	Grade Sorte	Cutting data Schnittdaten			
			V (m/min)	f (mm/z)		
				-PF	-PM	-PR
P Low-carbon steel Soft steel Niedriglegierter Kohlenstoffstahl Baustahl High-carbon steel Alloy steel Hochleg. Kohlenstoffstahl Leg. Stahl Alloy tool steel Leg. Werkzeugstahl	≤180	YBM251	270(220-350)	0.15(0.1-0.2)	0.2 (0.1-0.3)	0.3 (0.2-0.4)
		YBG202	270(200-360)	0.15(0.1-0.2)	0.2 (0.1-0.3)	0.3 (0.2-0.4)
		YBG302	230 (170-350)	0.15(0.1-0.2)	0.2 (0.1-0.3)	0.3 (0.2-0.4)
	180—280	YBM251	240 (200-320)	0.15(0.1-0.2)	0.2 (0.1-0.3)	0.3 (0.2-0.4)
		YBG202	240 (180-350)	0.15(0.1-0.2)	0.2 (0.1-0.3)	0.3 (0.2-0.4)
		YBG302	220 (150-330)	0.15(0.1-0.2)	0.2 (0.1-0.3)	0.3 (0.2-0.4)
	280—350	YBM251	220 (180-300)	0.1(0.1-0.2)	0.2 (0.1-0.3)	0.3 (0.2-0.4)
		YBG202	220 (170-340)	0.1(0.1-0.2)	0.2 (0.1-0.3)	0.3 (0.2-0.4)
		YBG302	190 (130-300)	0.15(0.1-0.2)	0.2 (0.1-0.3)	0.3 (0.2-0.4)
M Stainless steel Rostfreier Stahl	≤270	YBM251	150 (120-240)	0.1(0.1-0.2)	0.2 (0.1-0.3)	0.3 (0.2-0.4)
		YBG202	160 (110-270)	0.1(0.1-0.2)	0.2 (0.1-0.3)	0.3 (0.2-0.4)
		YBG302	140 (100-250)	0.15(0.1-0.2)	0.2 (0.1-0.3)	0.3 (0.2-0.4)
K Cast iron Gusseisen	180—250	YBG102	210 (120-300)	0.15(0.1-0.2)	0.2 (0.1-0.3)	0.3 (0.2-0.4)
		YBD152	240 (180-300)	0.15(0.1-0.2)	0.2 (0.1-0.3)	0.3 (0.2-0.4)
		YBD252	200 (150-250)	0.15(0.1-0.2)	0.2 (0.1-0.3)	0.3 (0.2-0.4)
				-LH		
N	Al alloy Leg. Alu	-	YD101	300-	0.15 (0.05-0.3)	

B

Milling Tools
Fräser

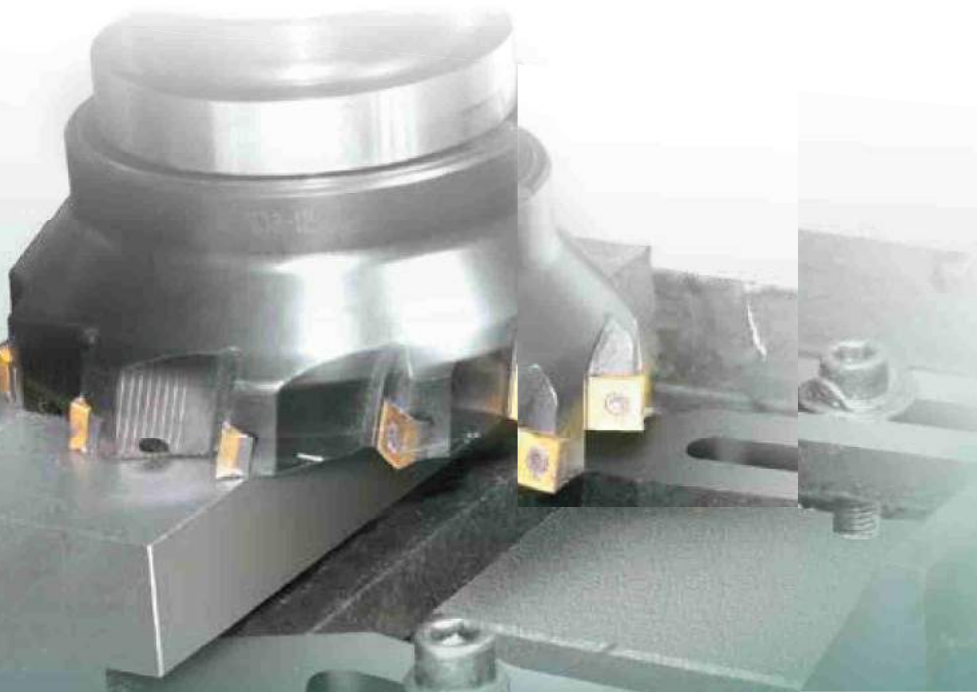

Case study for FMP02 Bearbeitungsbeispiel für FMP02



- Tool · Werkzeug: FMP02-100-B32-SE12-054
- Inserts · WSP: SEET120308PER-PM/YBD252

Workpiece material
Werkstückstoff: HT300/ GG30 (HB150)
Cooling system: dry cutting
Kühlsystem: trocken

Machine: vertical machining center
Maschine: vertikales Maschinen-Center

Cutting data
Schnittdaten:
 $V_c=200\text{m/min}$
 $a_p=3\text{mm}$
 $f_z=0.2\text{mm/z}$
 $a_e=80\text{mm}$

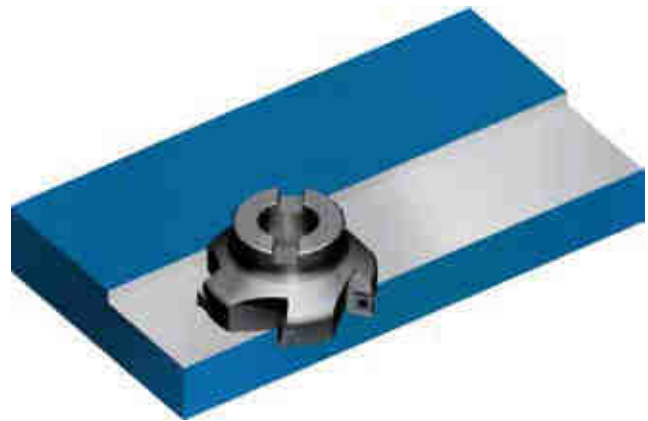

B

Milling Tools
Fräser

● Wear comparison of insert Verschleißvergleich der WSP

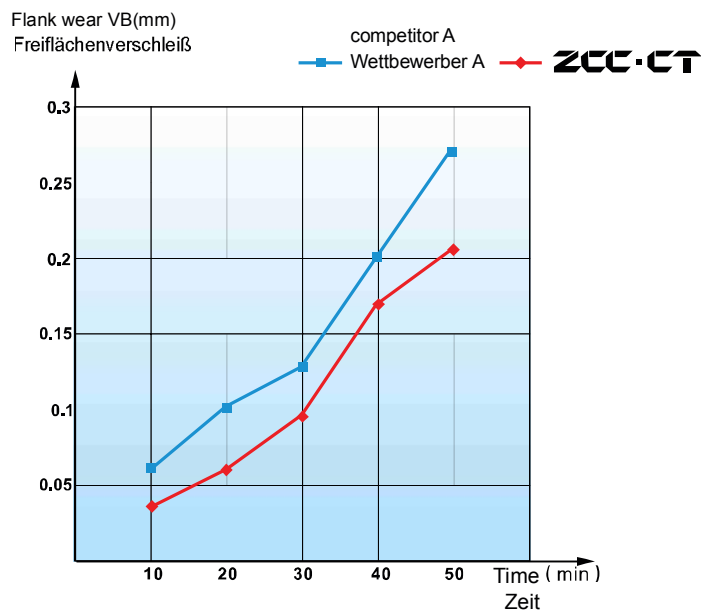

Milling · Fräsen

Indexable Milling Tools · Wendepplattenfräser

Face Milling Tools · Planfräser

Kr:89°



FMP03 P M K

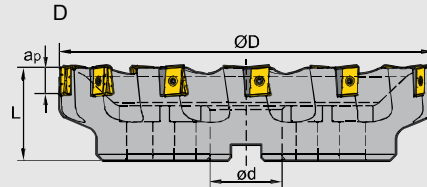
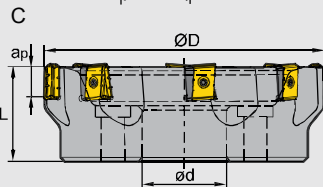
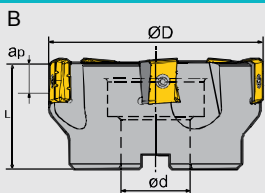

Type Typ	Stock Lager		Ø D	Ø d	L	apmax	No. of teeth Zähne	Insert WSP	Coupling Aufnahme	Weight Gewicht (kg)
	R	L								
FMP03 -125-B40-LN15-06	●	○	125	40	63	12	6	LNKT1506EN-ZR	B	3.2
-160-C40-LN15-08	●	○	160	40	63	12	8		C	5.1
-200-C60-LN15-10	●	○	200	60	70	12	10		C	7.5
-250-C60-LN15-12	●	○	250	60	70	12	12		C	12.2
-315-D60-LN15-16	○	○	315	60	80	12	16		D	23.7
-125-B40-LN20-06	○	○	125	40	63	16	6	LNKT2007DN-ZR	B	3.3
-160-C40-LN20-08	●	○	160	40	63	16	8		C	5.3
-200-C60-LN20-10	●	○	200	60	70	16	10		C	8.8
-250-C60-LN20-12	●	○	250	60	70	16	12		C	14.0
-315-D60-LN20-15	○	○	315	60	80	16	15		D	23.9
-125-B40-LN25-05	○	○	125	40	63	20	5	LNKT2510-ZR	B	3.3
-160-C40-LN25-06	○	○	160	40	63	20	6		C	5.1
-200-C60-LN25-08	○	○	200	60	70	20	8		C	8.9
-250-C60-LN25-10	●	○	250	60	70	20	10		C	12.0
-315-D60-LN25-12	○	○	315	60	80	20	12		D	21.9

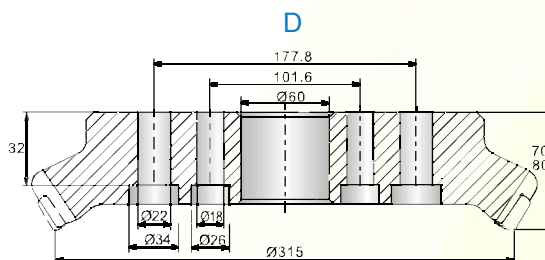
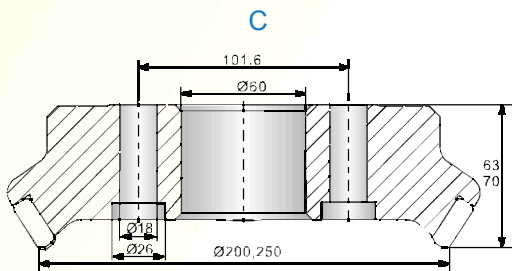
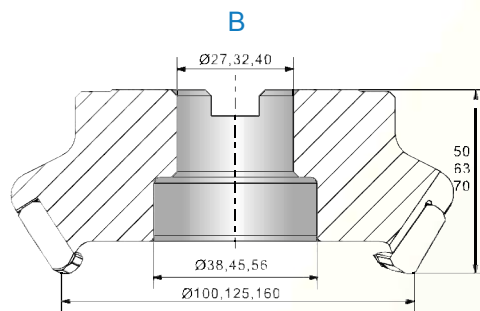
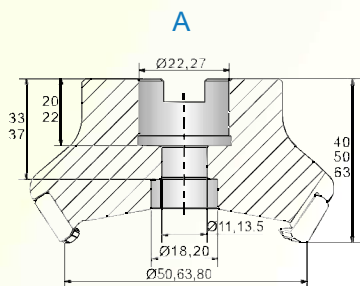

● Ex Stock / ab Lager ○ On demand / auf Anfrage

Spare Parts · Ersatzteile

Diameter Durchmesser Ø D	Insert Platte	shim Unterlage	Screw Schraube	Shim Screw Unterlagschraube	Wrench Schlüssel	Wrench Schlüssel	
Ø125 ~ Ø315	LN15	LLN15-ZR	I60M4×12	I60M3×7	WT15IS	WT10IS	
Ø125 ~ Ø315	LN20	LLN20R-ZR	I60M4×15	I60M3×7	WT15IS	WT10IS	
Ø125 ~ Ø315	LN25	LLN25R-ZR	I60M5×17	I60M3.5×10.4	WT20IT	WT15IS	

Applicable inserts · Wendeschneidplatten

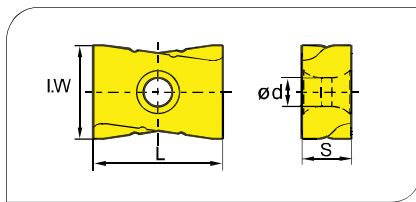

- Ideal Machining Condition / Gute Bearbeitungsbedingungen
- Normal Machining Condition / Normale Bearbeitungsbedingungen
- Unfavorable Machining Condition / Ungünstige Bearbeitungsbedingungen

Workpiece Material / Werkstoffe	P	M	K	N	S	YBC301	YBC302	YBC401	YBM251	YBM253	YBM351	YBD152	YBD252	YBG102	YBG202	YBG205	YBG302	YBG152	YBG252	YNG151	YNG151C	YC30S	YD101	YD201
P Steel / Stahl	●	●	●	●	●	●	●	●	●	●	●	●	●	●	●	●	●	●	●	●	●	●	●	●
M Stainless Steel / Rostfreier Stahl	●	●	●	●	●	●	●	●	●	●	●	●	●	●	●	●	●	●	●	●	●	●	●	●
K Cast iron / Gusseisen	●	●	●	●	●	●	●	●	●	●	●	●	●	●	●	●	●	●	●	●	●	●	●	●
N Non-ferrous material / Ne Metalle	●	●	●	●	●	●	●	●	●	●	●	●	●	●	●	●	●	●	●	●	●	●	●	●
S Heat-resistant steel / Warmfester Stahl	●	●	●	●	●	●	●	●	●	●	●	●	●	●	●	●	●	●	●	●	●	●	●	●

Insert shape Plattenform	Type Typ	Dimension (mm) / Abmessung				CVD Coating / CVD Beschicht.								PVD Coating / PVD Beschicht.				Cement / Zement	Carbide uncoat. / unbe. Hartmetall						
		L	I.W	S	d	YBC301	YBC302	YBC401	YBM251	YBM253	YBM351	YBD152	YBD252	YBG102	YBG202	YBG205	YBG302	YBG152	YBG252	YNG151	YNG151C	YC30S	YD101	YD201	
	LNKT1506EN-ZR	15.875	14	6.35	4.6	●			●		●	●	●				●								
	LNKT2007DN-ZR	20	17	7.94	4.6						●	●					●								
	LNKT2510-ZR	25	18	9.525	5.5						●	●					●								

Recommended cutting data · Empfohlene Schnittdaten

Workpiece material / Werkstückstoff	Hardness HB / Härte	Grade / Sorte	Cutting data / Schnittdaten	
			V (m/min)	f (mm/z)
P Low-carbon steel / Soft steel / Niedriglegierter Kohlenstoffstahl / Baustahl	≤180	YBG302	180 (150-300)	0.5 (0.2-0.8)
		YBM351	180 (150-300)	0.5 (0.2-0.8)
	180-280	YBG302	150 (120-280)	0.5 (0.2-0.8)
		YBM351	140 (120-280)	0.5 (0.2-0.8)
Alloy tool steel / Leg. Werkzeugstahl	280-350	YBG302	120 (80-250)	0.45 (0.2-0.6)
		YBM351	100 (80-250)	0.45 (0.2-0.6)
M Stainless steel / Rostfreier Stahl	≤270	YBG302	120 (80-200)	0.45 (0.2-0.6)
		YBM351	100 (80-200)	0.45 (0.2-0.6)
K Cast iron / Gusseisen	180-250	YBD152	150 (120-200)	0.3 (0.2-0.5)
		YBD252	130 (110-200)	0.3 (0.2-0.5)

Applicable tool / Werkzeug
B11-B18

Tools code key / Werkzeug ISO
B26-B27

Grade selection guide / Sortenauswahl
B19-B23

Technical data / Technische Daten
B215-B220

Face Milling Tools · Planfräser



FMR01 **P** **M** **K**

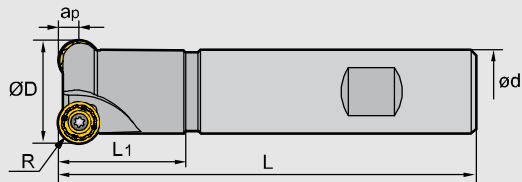

Specification of tools · Werkzeug Beschreibung

Type Typ	Stock Lager	Dimension (mm) Abmessung						No. of teeth Zähne	Weight Gewicht (kg)
		Ø D	Ø d	L	L1	R	apmax		
FMR01									
-025-XP20-RC10-02	●	25	20	100	30	5	5	2	0.2
-025-XP20-RC10-02C	○	25	20	100	30	5	5	2	0.2
-032-XP25-RC10-02	●	32	25	120	35	5	5	2	0.5
-032-XP25-RC10-02C	○	32	25	120	35	5	5	2	0.5
-040-XP32-RC12-03	●	40	32	120	40	6	6	3	0.7
-040-XP32-RC12-03C	○	40	32	120	40	6	6	3	0.7
-050-XP32-RC12-03	●	50	32	120	40	6	6	3	0.8
-050-XP32-RC12-03C	○	50	32	120	40	6	6	3	0.8

Spare Parts · Ersatzteile

Diameter Durchmesser Ø D	Screw Schraube	Wrench Schlüssel
Ø25 - Ø32	I60M4×8.4	WT15S
Ø40 - Ø50	I60M3.5×10	



● Ex Stock / ab Lager ○ On demand / auf Anfrage

Applicable inserts · Wendeschneidplatten

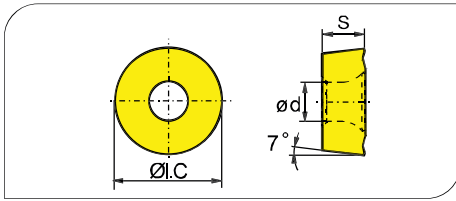

- Ideal Machining Condition / Gute Bearbeitungsbedingungen
- Normal Machining Condition / Normale Bearbeitungsbedingungen
- Unfavorable Machining Condition / Ungünstige Bearbeitungsbedingungen

Workpiece Material / Werkstoff	P	M	K	N	S	YBC301	YBC302	YBC401	YBM251	YBM253	YBM351	YBD152	YBD252	YBG102	YBG202	YBG205	YBG302	YBG152	YBG252	YNG151	YNG151C	YC30S	YD101	YD201	
P Steel / Stahl	●	●	●	●	●	●	●	●	●	●	●	●	●	●	●	●	●	●	●	●	●	●	●	●	●
M Stainless Steel / Rostfreier Stahl	●	●	●	●	●	●	●	●	●	●	●	●	●	●	●	●	●	●	●	●	●	●	●	●	●
K Cast iron / Gusseisen	●	●	●	●	●	●	●	●	●	●	●	●	●	●	●	●	●	●	●	●	●	●	●	●	●
N Non-ferrous material / Ne Metalle	●	●	●	●	●	●	●	●	●	●	●	●	●	●	●	●	●	●	●	●	●	●	●	●	●
S Heat-resistant steel / Warmfester Stahl	●	●	●	●	●	●	●	●	●	●	●	●	●	●	●	●	●	●	●	●	●	●	●	●	●

Insert shape / Plattenform	Type / Typ	Dimension (mm) / Abmessung			CVD Coating / CVD Beschicht.								PVD Coating / PVD Beschicht.				Cermets / Cermet		Carbide uncoat. / unbe. Hartmetall					
		I.C	S	d	YBC301	YBC302	YBC401	YBM251	YBM253	YBM351	YBD152	YBD252	YBG102	YBG202	YBG205	YBG302	YBG152	YBG252	YNG151	YNG151C	YC30S	YD101	YD201	
	RCKT10T3MO-DM	10.0	3.97	4.4	●	●								●	○									
	RCKT1204MO-DM	12.0	4.76	4.0	●	●	●		●	○				●	○									
	RCKT1204MO-DR	12.0	4.76	4.0	●	●	●		●						○									
	RCKT1204MO-ER	12.0	4.76	4.0					●	○														

Recommended cutting data · Empfohlene Schnittdaten

Workpiece material / Werkstückstoff	Hardness HB / Härte	Grade / Sorte	Cutting data · Schnittdaten			
			V (m/min)	f (mm/z)		
				-DM	-DR	
P Low-carbon steel / Soft steel / Niedriglegierter Kohlenstoffstahl / Baustahl	≤180	YBM251	270 (220-350)	0.2(0.1-0.5)	0.3 (0.2-0.8)	
		YBC301				
		YBM351	220 (180-300)	0.25(0.1-0.5)	0.3 (0.2-0.8)	
	YBC401					
		YBG202	270 (200-360)	0.2(0.1-0.5)	0.3 (0.2-0.8)	
	High-carbon steel / Alloy steel / Hochleg. Kohlenstoffstahl / Leg. Stahl	180-280	YBM251	240 (200-320)	0.2(0.1-0.5)	0.3 (0.2-0.8)
			YBM253			
			YBC301	200 (160-280)	0.25(0.1-0.5)	0.3 (0.2-0.8)
			YBM351			
YBC401	240 (180-350)	0.2(0.1-0.5)	0.3 (0.2-0.8)			
Alloy tool steel / Leg. Werkzeugstahl	280-350	YBM251	220 (180-300)	0.2(0.1-0.4)	0.3 (0.2-0.6)	
		YBM253				
		YBC301	180 (150-250)	0.2(0.1-0.5)	0.3 (0.2-0.8)	
		YBM351				
YBC401	220 (170-340)	0.2(0.1-0.4)	0.3 (0.2-0.6)			
M Stainless steel / Rostfreier Stahl	≤270	YBM251	150 (120-240)	0.2(0.1-0.4)	0.3 (0.2-0.6)	
		YBM253				
		YBM351	150 (100-220)	0.2(0.1-0.4)	0.3 (0.2-0.6)	
YBC401						
	YBG202	160 (110-270)	0.2(0.1-0.4)	0.3 (0.2-0.6)		
K Cast iron / Gusseisen	180-250	YBD152	210 (120-300)	0.2(0.1-0.5)	0.3 (0.2-0.8)	

Applicable tool / Werkzeug: **B11-B18**

Tools code key / Werkzeug ISO: **B26-B27**

Grade selection guide / Sortenauswahl: **B19-B23**

Technical data / Technische Daten: **B215-B220**

Milling · Fräsen

Indexable Milling Tools · Wendeplattenfräser

Case study for FMR01
Bearbeitungsbeispiel für FMR01

Workpiece material
Werkstückstoff: 42CrMo (HRC35)
Cooling system: dry cutting
Kühlsystem: trocken

Machine: vertical machining center
Maschine: vertikales Maschinen-Center

Cutting data
Schnittdaten:
 $V_c=200\text{m/min}$
 $a_p=3\text{mm}$
 $f_z=0.2\text{mm/z}$



- Tool · Werkzeug: FMR01-025-XP20-RC10-02
- Inserts · WSP: RCKT10T3MO-DM/YBG202



● Wear comparison of insert Verschleißvergleich der WSP

ZCC-CT

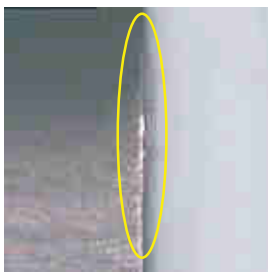

22 minutes later

Competitor A
Wettbewerber A



22 minutes later

● Ex Stock / ab Lager ○ On demand / auf Anfrage

Face Milling Tools · Planfräser



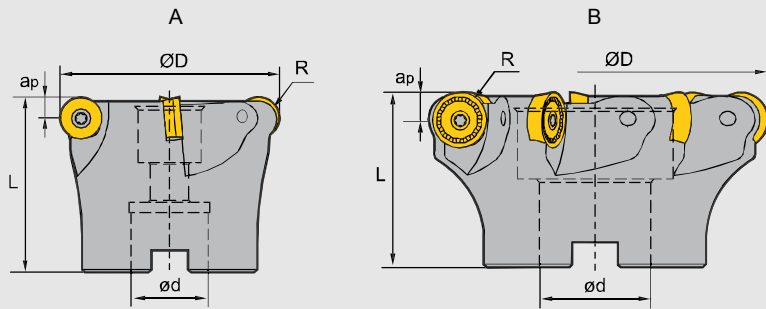

FMR02 P M K



Specification of tools · Werkzeug Beschreibung

Type Typ	Stock Lager	Dimension (mm) Abmessung					No. of teeth Zähne	Coupling Aufnahme	Weight Gewicht (kg)
		Ø D	Ø d	L	R	apmax			
FMR02 050-A22-RC12-05C	●	50	22	50	6	6	5	A	0.7
052-A22-RC12-05C	●	52	22	50	6	6	5	A	0.7
063-A22-RC12-04	●	63	22	50	6	6	4	A	0.7
063-A22-RC12-04C	●	63	22	50	6	6	4	A	0.7
063-A22-RC12-06	●	63	22	50	6	6	4	A	0.7
063-A22-RC12-06C	●	63	22	50	6	6	6	A	0.7
063-A22-RC16-04	●	63	22	50	8	8	4	A	0.7
063-A22-RC16-04C	●	63	22	50	8	8	4	A	0.7
080-A27-RC12-07C	●	80	27	50	6	6	7	B	0.7
080-B27-RC16-05	●	80	27	50	8	8	5	B	0.7
080-B27-RC16-05C	○	80	27	50	8	8	5	B	0.7
080-A27-RC20-04	●	80	27	50	10	10	4	A	0.7
080-A27-RC20-04C	●	80	27	50	10	10	4	A	0.7
100-B32-RC16-06	●	100	32	63	8	8	6	B	1.2
100-B32-RC16-06C	●	100	32	63	8	8	6	B	1.2
100-B32-RC20-05	●	100	32	63	10	10	5	B	1.2
100-B32-RC20-05C	●	100	32	63	10	10	5	B	1.2
100-B32-RC20-06	●	100	32	63	10	10	6	B	1.2
100-B32-RC20-06C	●	100	32	63	10	10	6	B	1.2
125-B40-RC20-06	●	125	40	63	10	10	6	B	1.2
125-B40-RC20-06C	●	125	40	63	10	10	6	B	1.2
125-B40-RC20-07	●	125	40	63	10	10	7	B	2.2
125-B40-RC20-07C	●	125	40	63	10	10	7	B	2.2
160-B40-RC20-08	●	160	40	63	10	10	8	B	4.2
160-B40-RC20-08C	○	160	40	63	10	10	8	B	4.2
250-B40-RC20-10	○	250	40	63	10	10	10	B	-

Spare Parts · Ersatzteile

Diameter Durchmesser Ø D	Insert WSP	Screw Schraube	Wrench Schlüssel	
				
Ø63-Ø80	RC12	I60M3.5×10	WT15IS	--
Ø63-Ø100	RC16	I60M5×13	--	WT20IT
Ø80-Ø250	RC20	I43M6×16	--	WT25IT



Applicable tool B11-B18
Werkzeug

Tools code key B26-B27
Werkzeug ISO

Grade selection guide B19-B23
Sortenauswahl

Technical data B215-B220
Technische Daten

Milling · Fräsen

Indexable Milling Tools · Wendepplattenfräser

Applicable inserts · Wendeschneidplatten

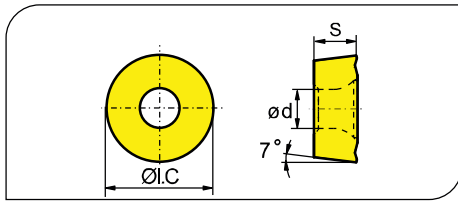

- Ideal Machining Condition / Gute Bearbeitungsbedingungen
- Normal Machining Condition / Normale Bearbeitungsbedingungen
- Unfavorable Machining Condition / Ungünstige Bearbeitungsbedingungen

Workpiece Material / Werkstückstoff	P	M	K	N	S	Steel / Stahl	Stainless Steel / Rostfreier Stahl	Cast iron / Gusseisen	Non-ferrous material / Ne Metalle	Heat-resistant steel / Warmfester Stahl
P	●	●	●	●	●	●	●	●	●	●
M	●	●	●	●	●	●	●	●	●	●
K	●	●	●	●	●	●	●	●	●	●
N	●	●	●	●	●	●	●	●	●	●
S	●	●	●	●	●	●	●	●	●	●

Insert shape / Plattenform	Type / Typ	Dimension (mm) / Abmessung			CVD Coating / CVD Beschicht.						PVD Coating / PVD Beschicht.						Cermet / Cermet	Carbide uncoat. / unbe. Hartmetall				
		I.C	S	d	YBC301	YBC302	YBC401	YBM251	YBM253	YBM351	YBD152	YBD252	YBG102	YBG202	YBG205	YBG302		YBG152	YBG252	YNG151	YNG151C	YC30S
	RCKT1204MO-DM	12.0	4.76	4.0	●	●	●	●	○				●		○							
	RCKT1606MO-DM	16.0	6.35	5.56	●	●	○							○	●							
	RCKT2006MO-DM	20.0	6.35	6.55	○	○	○															
	RCKT1204MO-DR	12.0	4.76	4.0	●	●	●	●						○								
	RCKT1606MO-DR	16.0	6.35	5.56	●	●			●	●												
	RCKT2006MO-DR	20.0	6.35	6.55	●	●			●	●												
	RCKT1204MO-ER	12.0	4.76	4.0					●	○												
	RCKT1606MO-ER	16.0	6.35	5.56					●	○												
	RCKT2006MO-ER	20.0	6.35	6.55					●	○												

Recommended cutting data · Empfohlene Schnittdaten

Workpiece material / Werkstückstoff	Hardness HB / Härte	Grade / Sorte	Cutting data · Schnittdaten			
			V (m/min)	f (mm/z)		
				-DM	-DR	
P Low-carbon steel / Soft steel / Niedriglegierter Kohlenstoffstahl / Baustahl High-carbon steel / Alloy steel / Hochleg. Kohlenstoffstahl Alloy tool steel / Leg. Werkzeugstahl	≤180	YBM251 / YBC301	270 (220-350)	0.2(0.1-0.5)	0.3 (0.2-0.8)	
		YBM351 / YBC401	220 (180-300)	0.25(0.1-0.5)	0.3 (0.2-0.8)	
		YBG202	270 (200-360)	0.2(0.1-0.5)	0.3 (0.2-0.8)	
	180-280	YBM251 / YBC301	240 (200-320)	0.2(0.1-0.5)	0.3 (0.2-0.8)	
		YBM351 / YBC401	200 (160-280)	0.25(0.1-0.5)	0.3 (0.2-0.8)	
		YBG202	240 (180-350)	0.2(0.1-0.5)	0.3 (0.2-0.8)	
	280-350	YBM251 / YBC301	220 (180-300)	0.2(0.1-0.4)	0.3 (0.2-0.6)	
		YBM351 / YBC401	180 (150-250)	0.2(0.1-0.5)	0.3 (0.2-0.8)	
		YBG202	220 (170-340)	0.2(0.1-0.4)	0.3 (0.2-0.6)	
M Stainless steel / Rostfreier Stahl	≤270	YBM251 / YBM253	150 (120-240)	0.2(0.1-0.4)	0.3 (0.2-0.6)	
		YBM351 / YBC401	150 (100-220)	0.2(0.1-0.4)	0.3 (0.2-0.6)	
		YBG202	160 (110-270)	0.2(0.1-0.4)	0.3 (0.2-0.6)	
K Cast iron / Gusseisen	180-250	YBD152	210 (120-300)	0.2(0.1-0.5)	0.3 (0.2-0.8)	

● Ex Stock / ab Lager ○ On demand / auf Anfrage

Face Milling Tools · Planfräser



FMR03 P M K



Walter-System

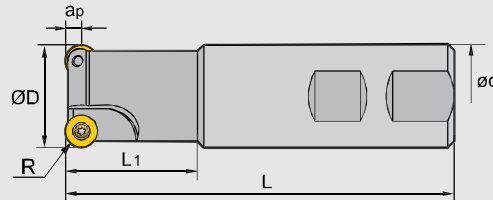

Specification of tools · Werkzeug Beschreibung

Type Typ	Stock Lager	Dimension (mm) Abmessung							No. of teeth Zähne	Weight Gewicht (kg)
		Ø D	Ø d	L	L1	R	apmax			
FMR03	-016-XP16-RD08-02	○	16	16	100	25	4	4	2	0.1
	-016-XP16-RD08-02C	○	16	16	100	25	4	4	2	0.1
	-025-XP25-RD08-02	●	25	25	100	30	4	4	2	0.3
	-025-XP25-RD08-02C	●	25	25	100	30	4	4	2	0.3
	-032-XP32-RD10-02	●	32	32	120	40	5	5	2	0.7
	-032-XP32-RD10-02C	●	32	32	120	40	5	5	2	0.7
	-040-XP32-RD12-03	●	40	32	120	40	6	6	3	0.7
	-040-XP32-RD12-03C	●	40	32	120	40	6	6	3	0.7
	-050-XP32-RD12-04	●	50	32	120	40	6	6	4	0.8
	-050-XP32-RD12-04C	●	50	32	120	40	6	6	4	0.8

Spare Parts · Ersatzteile

Diameter Durchmesser Ø D	Screw Schraube	Wrench Schlüssel
Ø25	I60M3×7	WT09IP
Ø32-Ø50	I60M4×10	WT15IP



Applicable tool B11-B18
Werkzeug

Tools code key B26-B27
Werkzeug ISO

Grade selection guide B19-B23
Sortenauswahl

Technical data B215-B220
Technische Daten

Face Milling Tools · Planfräser

FMR03 P M K

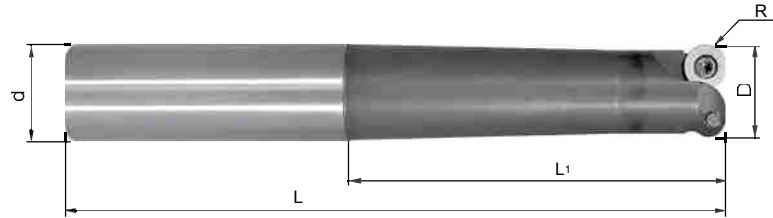

Depo-System

Type Typ	Stock Lager	Dimension (mm) Abmessung						No. of teeth Zähne	
		Ø D	Ø d	L	L ₁	R	a _{pmax}		
FMR03	-015-G16-XS RD0702-02	○	15	16	88	40	3.5	3.5	2
	-015-G16-XS RD0702-02C	○	15	16	88	40	3.5	3.5	2
	-015-G16-S RD0702-02	○	15	16	108	60	3.5	3.5	2
	-015-G16-S RD0702-02C	○	15	16	108	60	3.5	3.5	2
	-015-G20-M RD0702-02	○	15	20	130	80	3.5	3.5	2
	-015-G20-M RD0702-02C	○	15	20	130	80	3.5	3.5	2
	-015-G20-L RD0702-02	○	15	20	150	100	3.5	3.5	2
	-015-G20-L RD0702-02C	○	15	20	150	100	3.5	3.5	2
	-015-G25-XL RD0702-02	○	15	25	120	176	3.5	3.5	2
	-015-G25-XL RD0702-02C	○	15	25	120	176	3.5	3.5	2



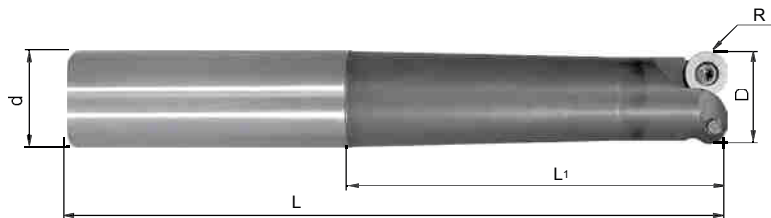

Inserts · WSP: RDKW0702MO**/ RDKW1003MO**



Type Typ	Stock Lager	Dimension (mm) Abmessung						No. of teeth Zähne	
		Ø D	Ø d	L	L ₁	R	a _{pmax}		
FMR03	-020-G20-XS RD1003-02	○	20	20	90	40	5	5	2
	-020-G20-XS RD1003-02C	○	20	20	90	40	5	5	2
	-020-G20-S RD1003-02	○	20	20	110	60	5	5	2
	-020-G20-S RD1003-02C	○	20	20	110	60	5	5	2
	-020-G25-M RD1003-02	○	20	25	136	80	5	5	2
	-020-G25-M RD1003-02C	○	20	25	136	80	5	5	2
	-020-G25-L RD1003-02	○	20	25	156	100	5	5	2
	-020-G25-L RD1003-02C	○	20	25	156	100	5	5	2
	-020-G25-XL RD1003-02	○	20	25	176	120	5	5	2
	-020-G25-XL RD1003-02C	○	20	25	176	120	5	5	2

Inserts · WSP: RDKW0702MO**/ RDKW1003MO**

Spare Parts · Ersatzteile

Type Typ	Screw Schraube	Wrench Schlüssel
FMR03**RD0702	 I60M2,5 x 5,0	 WT07P
FMR03**RD1003	 I60M3,5 x 7,7	 WT15P

● Ex Stock / ab Lager ○ On demand / auf Anfrage

Face Milling Tools · Planfräser



FMR04 P M K



Walter-System

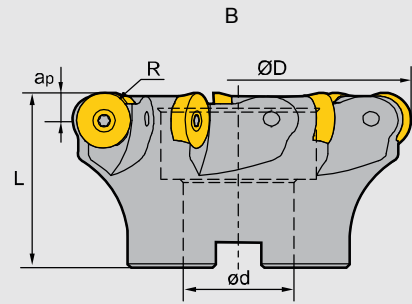
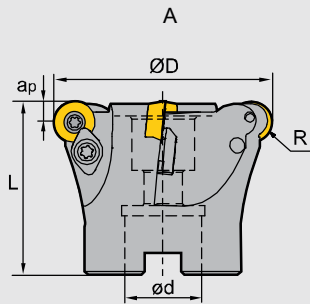

Specification of tools · Werkzeug Beschreibung

Type Typ	Stock Lager	Dimension (mm) Abmessung					No. of teeth Zähne	Coupling Aufnahme	Weight Gewicht (kg)
		Ø D	Ø d	L	R	apmax			
FMR04									
050-A22-RD12-03	●	50	22	40	6	6	3	A	0.3
050-A22-RD12-03C	●	50	22	40	6	6	3	A	0.3
063-A22-RD12-04	●	63	22	50	6	6	4	A	0.5
063-A22-RD12-04C	●	63	22	50	6	6	4	A	0.5
080-B27-RD16-05	●	80	27	50	8	8	5	B	1.2
080-B27-RD16-05C	●	80	27	50	8	8	5	B	1.2
100-B32-RD16-06	●	100	32	50	8	8	6	B	1.0
100-B32-RD16-06C	●	100	32	50	8	8	6	B	1.0
125-B40-RD20-06	○	125	40	63	10	10	6	B	1.9
125-B40-RD20-06C	○	125	40	63	10	10	6	B	1.9
160-B40-RD20-07	○	160	40	63	10	10	7	B	3.7
160-B40-RD20-07C	○	160	40	63	10	10	7	B	3.7

Inserts · WSP : RDKW1204MO**/ RDKW1605MO**/ RDKW2006MO

Spare Parts · Ersatzteile

Diameter Durchmesser Ø D	Screw Schraube	Clamp Pratze	Clamp Screw Schraube (Pratze)	Wrench Schlüssel	
Ø50-Ø63					
Ø80 -Ø100	I60M3.5×10	WD-204	I60M4×10	WT15IP	--
Ø125 -Ø160	I60M5×13	--	--	--	WT20IT
	I43M6×16				WT25IT



● Ex Stock / ab Lager ○ On demand / auf Anfrage

Face Milling Tools - Planfräser



FMR04 P M K

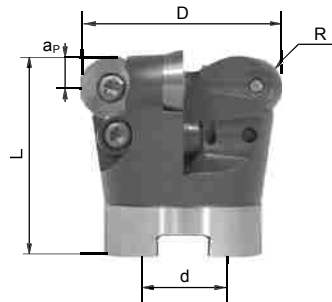

Depo-System

Type Typ	Stock Lager	Dimension (mm) Abmessung					No. of teeth Zähne	
		Ø D	Ø d	L	R	apmax		
FMR04	042-A16-RD1003-06	●	42	16	44	5	5	6
	042-A16-RD1003-06C	●	42	16	44	5	5	6
	052-A22-RD1003-07	●	52	22	50	5	5	7
	052-A22-RD1003-07C	●	52	22	50	5	5	7

Inserts - WSP: RDKW1003MO**

Type Typ	Stock Lager	Dimension (mm) Abmessung					No. of teeth Zähne	
		Ø D	Ø d	L	R	apmax		
FMR04	042-A16-RD12T3-05	●	42	16	42	6	6	5
	042-A16-RD12T3-05C	●	42	16	42	6	6	5
	052-A22-RD12T3-05	●	52	22	50	6	6	5
	052-A22-RD12T3-05C	●	52	22	50	6	6	5
	066-A27-RD12T3-06	●	66	27	50	6	6	6
	066-A27-RD12T3-06C	●	66	27	50	6	6	6
	080-A27-RD12T3-07	●	80	27	50	6	6	7
	080-A27-RD12T3-07C	●	80	27	50	6	6	7

Inserts - WSP: RDKW12T3MO**













Type Typ	Stock Lager	Dimension (mm) Abmessung					No. of teeth Zähne	
		Ø D	Ø d	L	R	apmax		
FMR04	*052-A22-RD1604-04	●	52	22	50	8	8	4
	*052-A22-RD1604-04C	●	52	22	50	8	8	4
	*052-A22-RD1604-05	●	52	22	50	8	8	5
	*052-A22-RD1604-05C	●	52	22	50	8	8	5
	066-A27-RD1604-05	●	66	27	50	8	8	5
	066-A27-RD1604-05C	●	66	27	50	8	8	5
	080-A27-RD1604-06	●	80	27	52	8	8	6
	080-A27-RD1604-06C	●	80	27	52	8	8	6
	100-B32-RD1604-07	●	100	32	52	8	8	7
	100-B32-RD1604-07C	●	100	32	52	8	8	7
	125-B40-RD1604-08	●	125	40	52	8	8	8
	125-B40-RD1604-08C	●	125	40	52	8	8	8
	160-B40-RD1604-09	●	160	40	52	8	8	9
	160-B40-RD1604-09C	○	160	40	52	8	8	9

Inserts - WSP: RDKW1604MO**

*= WX16N (außer für FMP04-052) (except for FMP04-052)

**= nur ab (Ø 052) from (Ø 052)

Spare Parts - Ersatzteile

Type Typ	Screw Schraube	Clamp Klemmscheibe	Clamp Screw Klemmschraube	Wrench Schlüssel
FMR04**RD1003	 160M3,5 x 7,7	 -	 -	 WT15P
FMR04**RD12T3	 160M3,5 x 7,7	 -	 **LOM 3,5 x 7,1	 WT15P
FMR04**RD1604	 160M4,5 x 1,0	 *WX16N	 -	 WT20T

Applicable tool B11-B18
Werkzeug

Tools code key B26-B27
Werkzeug ISO

Grade selection guide B19-B23
Sortenauswahl

Technical data B215-B220
Technische Daten

Milling - Fräsen

Indexable Milling Tools - Wendepplattenfräser

Applicable inserts - Wendeschneidplatten

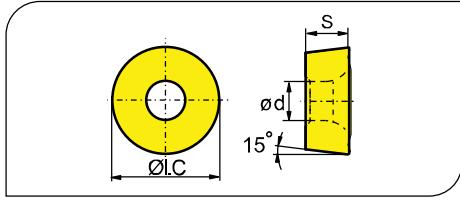

- Ideal Machining Condition / Gute Bearbeitungsbedingungen
- Normal Machining Condition / Normale Bearbeitungsbedingungen
- Unfavorable Machining Condition / Ungünstige Bearbeitungsbedingungen

Workpiece Material / Werkstückstoff	P	M	K	N	S	YBC301	YBC302	YBC401	YBM251	YBM253	YBM351	YBD152	YBD252	YBG102	YBG202	YBG205	YBG302	YBG152	YBG252	YNG151	YNG151C	YC305	YD101	YD201
P Steel / Stahl	●	●	●	●	●	●	●	●	●	●	●	●	●	●	●	●	●	●	●	●	●	●	●	●
M Stainless Steel / Rostfreier Stahl	●	●	●	●	●	○	●	●	●	●	●	●	●	●	●	●	●	●	●	●	●	●	●	●
K Cast iron / Gusseisen	●	●	●	●	●	○	●	●	●	●	●	●	●	●	●	●	●	●	●	●	●	●	●	●
N Non-ferrite material / Ne Metalle	●	●	●	●	●	○	●	●	●	●	●	●	●	●	●	●	●	●	●	●	●	●	●	●
S Heat-resistant steel / Warmfester Stahl	●	●	●	●	●	○	●	●	●	●	●	●	●	●	●	●	●	●	●	●	●	●	●	●

Insert shape / Plattenform	Type / Typ	Dimension (mm) / Abmessung			CVD Coating / CVD Beschicht.				PVD Coating / PVD Beschicht.				Cermet / Cermet	Carbide uncoat. / unbe. Hartmetall											
		I.C	S	d	YBC301	YBC302	YBC401	YBM251	YBM253	YBM351	YBD152	YBD252		YBG102	YBG202	YBG205	YBG302	YBG152	YBG252	YNG151	YNG151C	YC305	YD101	YD201	
	RDKW1003MO	10.0	3.18	3.9				●	●					●	●										
	RDKW10T3MO	10.0	3.97	4.4	○	●				●				●	●										
	RDKW1204MO	12.0	4.76	4.4	○	●		●	●	●				●	●	●	○								
	RDKW12T3MO	12.0	3.97	3.9			○	●	●	●				●	●									○	
	RDKT12T3MO-EM	12.0	3.97	3.9							●														
	RDKW1604MO	16.0	4.76	5.2						●					●	●									
	RDKW1605MO	16.0	5.56	5.5							●				●		●								
	RDKW2006MO	20.0	6.35	6.5	●						●			○											

Recommended cutting data - Empfohlene Schnittdaten

Workpiece material / Werkstückstoff	Hardness HB / Härte	Grade / Sorte	Cutting data / Schnittdaten	
			V (m/min)	f (mm/z)
P Low-carbon steel / Soft steel / Niedriglegierter Kohlenstoffstahl / Baustahl	≤180	YBM251	270 (220-350)	0.2 (0.08-0.45)
		YBC301		
		YBM351	220 (180-300)	0.25 (0.15-0.45)
	180-280	YBG302		
		YBG202	270 (200-360)	0.2 (0.1-0.45)
		YBM251	240 (200-320)	0.2 (0.08-0.45)
	280-350	YBC301		
		YBM351	200 (160-280)	0.25 (0.15-0.45)
		YBG302		
M High-carbon steel / Alloy steel / Hochleg. Kohlenstoffstahl	≤270	YBG202	240 (180-350)	0.2 (0.1-0.45)
		YBM251	150 (120-240)	0.2 (0.08-0.45)
		YBC301		
K Alloy tool steel / Leg. Werkzeugstahl	180-250	YBM351	220 (180-300)	0.2 (0.08-0.45)
		YBG302	180 (150-250)	0.25 (0.15-0.45)
		YBG202	220 (170-340)	0.2 (0.1-0.45)
M Stainless steel / Rostfreier Stahl	≤270	YBM251	150 (120-240)	0.2 (0.08-0.45)
		YBM351	150 (100-220)	0.25 (0.1-0.45)
		YBG302		
K Cast iron / Gusseisen	180-250	YBG202	160 (110-270)	0.2 (0.1-0.45)
		YBG102	210 (120-300)	0.2 (0.1-0.45)

● Ex Stock / ab Lager ○ On demand / auf Anfrage

Case study for FMR04
Bearbeitungsbeispiel für FMA04



- Tool · Werkzeug: FMR04-063-A22-RD12-04
- Inserts · WSP: RDKW1204MO/YBG202

Workpiece material
Werkstückstoff: 42CrMo (HRC35)
Cooling system: dry cutting
Kühlsystem: trocken

Machine: vertical machining center
Maschine: vertikales Maschinen-Center

Cutting data
Schnittdaten:
Vc=200m/min
ap=3mm
fz=0.3mm/z



● Wear comparison after 90 min Verschleißvergleich nach 90 min

ZCC-CT



**Competitor A
Wettbewerber A**



Applicable tool | B11-B18
Werkzeug

Tools code key | B26-B27
Werkzeug ISO

Grade selection guide | B19-B23
Sortenauswahl

Technical data | B215-B220
Technische Daten

Milling · Fräsen

Indexable Milling Tools · Wendeplattenfräser

Square shoulder milling tools · Eckfräser

Kr:90°



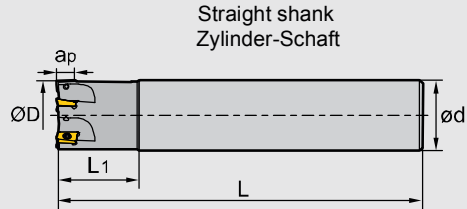

EMP01 P M K N



Specification of tools · Werkzeug Beschreibung

	Type Typ	Stock Lager	Dimensions (mm) Abmessungen					No. of teeth Zähne	Weight Gewicht (kg)
			$\varnothing D$	$\varnothing d$	L	L ₁	a _{pmax}		
EMP01	012-G16-AP11-01	●	12	16	85	25	10.5	1	0.1
	012-G16-AP11-01C	●	12	16	85	25	10.5	1	0.1
Straight shank	016-G16-AP11-02	●	16	16	90	25	10.5	2	0.1
	016-G16-AP11-02C	●	16	16	90	25	10.5	2	0.1
Zylinder- Schaft	020-G20-AP11-02	●	20	20	100	30	10.5	2	0.2
	020-G20-AP11-02C	●	20	20	100	30	10.5	2	0.2
	020-G20-AP11-03	●	20	20	100	30	10.5	3	0.2
	020-G20-AP11-03C	○	20	20	100	30	10.5	3	0.2
	025-G25-AP11-03	●	25	25	115	35	10.5	3	0.4
	025-G25-AP11-03C	●	25	25	115	35	10.5	3	0.4
	025-G25-AP11-04	●	25	25	115	35	10.5	4	0.4
	025-G25-AP11-04C	○	25	25	115	35	10.5	4	0.4
	032-G32-AP11-04	●	32	32	125	40	10.5	4	0.7
	032-G32-AP11-04C	●	32	32	125	40	10.5	4	0.7
	025-G25-AP16-02	●	25	25	115	35	15.5	2	0.4
	025-G25-AP16-02C	●	25	25	115	35	15.5	2	0.4
	032-G32-AP16-03	●	32	32	125	40	15.5	3	0.7
	032-G32-AP16-03C	●	32	32	125	40	15.5	3	0.7
	040-G32-AP16-03	●	40	32	130	42	15.5	3	0.7
	040-G32-AP16-03C	●	40	32	130	42	15.5	3	0.7
	040-G32-AP16-04	●	40	32	130	42	15.5	4	0.8
	040-G32-AP16-04C	●	40	32	130	42	15.5	4	0.8
	050-G32-AP16-05	●	50	32	135	45	15.5	5	1.0
	050-G32-AP16-05C	●	50	32	135	45	15.5	5	1.0
	063-G32-AP16-06	●	63	32	135	45	15.5	6	1.4
	063-G32-AP16-06C	●	63	32	135	45	15.5	6	1.4

Spare Parts · Ersatzteile

Diameter Durchmesser $\varnothing D$	Insert WSP	Screw Schraube	Wrench Schlüssel	
				
$\varnothing 12$ - $\varnothing 32$	AP11	I60M2.5×6.5T	WT08IP	--
$\varnothing 25$ - $\varnothing 63$	AP16	I60M4×8.4	--	WT15IS



● Ex Stock / ab Lager ○ On demand / auf Anfrage

Square shoulder milling tools · Eckfräser

Kr:90°



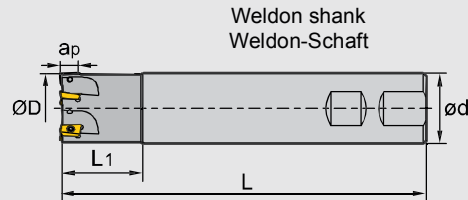

EMP01 P M K N



Specification of tools · Werkzeug Beschreibung

	Type Typ	Stock Lager	Dimensions (mm) Abmessungen					No. of teeth Zähne	Weight Gewicht (kg)
			Ø D	Ø d	L	L ₁	ap _{max}		
EMP01	012-XP16-AP11-01	●	12	16	85	25	10.5	1	0.1
	012-XP16-AP11-01C	●	12	16	85	25	10.5	1	0.1
Weldon shank	016-XP16-AP11-02	●	16	16	90	25	10.5	2	0.1
	016-XP16-AP11-02C	●	16	16	90	25	10.5	2	0.1
Zylinder-Schaft	020-XP20-AP11-02	●	20	20	100	30	10.5	2	0.2
	020-XP20-AP11-02C	●	20	20	100	30	10.5	2	0.2
	020-XP20-AP11-03	●	20	20	100	30	10.5	3	0.2
	020-XP20-AP11-03C	○	20	20	100	30	10.5	3	0.2
	025-XP25-AP11-03	●	25	25	115	35	10.5	3	0.4
	025-XP25-AP11-03C	●	25	25	115	35	10.5	3	0.4
	025-XP25-AP11-04	●	25	25	115	35	10.5	4	0.4
	025-XP25-AP11-04C	○	25	25	115	35	10.5	4	0.4
	032-XP32-AP11-04	●	32	32	125	40	10.5	4	0.7
	032-XP32-AP11-04C	●	32	32	125	40	10.5	4	0.7
	025-XP25-AP16-02	●	25	25	115	35	15.5	2	0.4
	025-XP25-AP16-02C	●	25	25	115	35	15.5	2	0.4
	032-XP32-AP16-03	●	32	32	125	40	15.5	3	0.7
	032-XP32-AP16-03C	●	32	32	125	40	15.5	3	0.7
	040-XP32-AP16-04	●	40	32	130	42	15.5	4	0.8
	040-XP32-AP16-04C	●	40	32	130	42	15.5	4	0.8
	050-XP32-AP16-05	●	50	32	135	45	15.5	5	1.0
	050-XP32-AP16-05C	●	50	32	135	45	15.5	5	1.0
	063-XP32-AP16-06	○	63	32	135	45	15.5	6	1.4
	063-XP32-AP16-06C	○	63	32	135	45	15.5	6	1.4

Spare Parts · Ersatzteile

Diameter Durchmesser Ø D	Insert WSP	Screw Schraube	Wrench Schlüssel	
				
Ø12-Ø32	AP11	I60M2.5×6.5T	WT08IP	--
Ø25-Ø63	AP16	I60M4×8.4	--	WT15IS



Applicable tool B11-B18
Werkzeug

Tools code key B26-B27
Werkzeug ISO

Grade selection guide B19-B23
Sortenauswahl

Technical data B215-B220
Technische Daten

Milling · Fräsen

Indexable Milling Tools · Wendepplattenfräser

Applicable inserts · Wendeschneidplatten

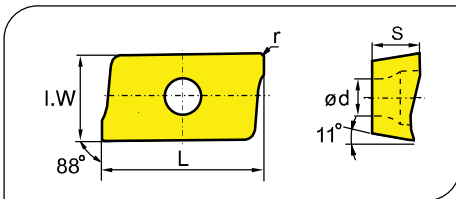

Workpiece Material Werkstoffe	Steel Stahl	Stainless Steel Rostfreier Stahl	Cast iron Gusseisen	Non-ferrite material Nf Metalle	Heat-resistant steel Warmfester Stahl
P	●	●	●	●	●
M	●	●	●	●	●
K	●	●	●	●	●
N	●	●	●	●	●
S	●	●	●	●	●

Insert shape Plattenform	Type Typ	Dimensions (mm) Abmessungen					CVD Coating CVD Beschicht.						PVD Coating PVD Beschicht.				Cemet Cemet	Carbide uncoat. unbe. Hartmetall								
		L	I.W	S	d	r	YBC301	YBC302	YBC401	YBM251	YBM253	YBM351	YBD152	YBD252	YBG102	YBG202	YBG205	YBG302	YBG152	YBG252	YNG151	YNG151C	YC30S	YD101	YD201	
	APKT11T304-PF	12.24	6.5	3.6	2.8	0.4	○		●						●	●		●								
	APKT11T308-PF	12.24	6.5	3.6	2.8	0.8			○							●										
	APKT11T312-PF	12.24	6.5	3.6	2.8	1.2										○										
	APKT11T316-PF	12.24	6.5	3.6	2.8	1.6										○										
	APKT160408-PF	17.877	9.33	5.76	4.4	0.8	●		○	●					●	●		●								
	APKT11T304-PM	12.24	6.5	3.6	2.8	0.4	●	●	○	●	●			●	●		●									
	APKT11T308-PM	12.24	6.5	3.6	2.8	0.8	●	●		●	●	●	●	●	●	●	●	●								
	APKT11T312-PM	12.24	6.5	3.6	2.8	1.2				○					○	●										
	APKT11T316-PM	12.24	6.5	3.6	2.8	1.6				●					○	●										
	APKT160408-PM	17.877	9.33	5.76	4.4	0.8	●	●	●	●	●	●	●	●	●	●	●	●	●							
	APKT11T304-PR	12.24	6.5	3.6	2.8	0.4			●			○						○								
	APKT11T308-PR	12.24	6.5	3.6	2.8	0.8												○								
	APKT11T312-PR	12.24	6.5	3.6	2.8	1.2												○								
	APKT11T316-PR	12.24	6.5	3.6	2.8	1.6												○								
	APKT160408-PR	17.877	9.33	5.76	4.4	0.8												○								
	APKT11T304-LH	12.24	6.5	3.6	2.8	0.4																		●	●	
	APKT11T308-LH	12.24	6.5	3.6	2.8	0.8																		●	●	
	APET160402-LH	17.877	9.33	5.76	4.4	0.2																		○		
	APKT160408-LH	17.877	9.33	5.76	4.4	0.8																		●	●	
	APET160408PDFR-LH	17.877	9.33	5.76	4.4	0.8																		○		

● Ex Stock / ab Lager ○ On demand / auf Anfrage

Chipbreaker Selection EMP01 · Spanbrecher Auswahl EMP01

Application Anwendung	Finishing Schlichten	Semi-Finishing Mittlere Bearbeitung	Roughing Schruppen
P	-PF	-PM	-PR
M	-PF	-PM	-PR
K	-PF	-PM	
AL	-LH		

1 Square shoulder milling 1 Eckfräsen

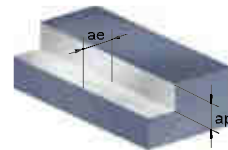

Recommended cutting data · Empfohlene Schnittdaten

Workpiece material Werkstück Material	Hardness HB Härte	Grade Sorte	Cutting data Schnittdaten					
			V(m/min)	f(mm/z)			ae(mm)	
				-PF	-PM	-PR		
P	Low-carbon steel Soft steel Niedrig legierter Kohlenstoffstahl Baustahl	≤180	YBM251 YBC301	320 (240-400)	0.1 (0.08-0.2)	0.2 (0.1-0.3)	0.25(0.2-0.35)	≤0.5D
			YBM351	260 (180-380)	0.1 (0.08-0.2)	0.2 (0.1-0.3)	0.25(0.2-0.35)	≤0.5D
			YBG202 YBG205	320 (200-400)	0.1 (0.08-0.2)	0.2 (0.1-0.3)	0.25(0.2-0.35)	≤0.5D
			YBG302	280 (180-400)	0.1 (0.08-0.2)	0.2 (0.1-0.3)	0.25(0.2-0.35)	≤0.5D
	High-carbon steel Alloy steel Hoch Leg. Kohlenstoffstahl Leg. Stahl	180-280	YBM251 YBC301	280 (210-380)	0.1 (0.08-0.2)	0.2 (0.1-0.3)	0.25(0.2-0.3)	≤0.5D
			YBM351	240 (160-320)	0.1 (0.08-0.2)	0.2 (0.1-0.3)	0.25(0.2-0.35)	≤0.5D
			YBG202 YBG205	280 (180-350)	0.1 (0.08-0.2)	0.2 (0.1-0.3)	0.25(0.2-0.3)	≤0.5D
			YBG302	260 (150-380)	0.1 (0.08-0.2)	0.2 (0.1-0.3)	0.25(0.2-0.35)	≤0.5D
	Alloy tool steel Leg. Werkzeugstahl	280-350	YBM251 YBC301	260 (180-350)	0.1 (0.08-0.2)	0.2 (0.1-0.3)	0.25(0.2-0.3)	≤0.5D
			YBM351	220 (150-280)	0.1 (0.08-0.2)	0.2 (0.1-0.3)	0.25(0.2-0.35)	≤0.5D
			YBG202 YBG205	260 (160-330)	0.1 (0.08-0.2)	0.2 (0.1-0.3)	0.25(0.2-0.3)	≤0.5D
			YBG302	240 (120-350)	0.1 (0.08-0.2)	0.2 (0.1-0.3)	0.25(0.2-0.35)	≤0.5D
M	Stainless steel Rostfreier Stahl	≤270	YBM251	200 (120-270)	0.1 (0.08-0.2)	0.2 (0.1-0.3)	0.25(0.2-0.3)	≤0.5D
			YBM351	180 (150-300)	0.1 (0.08-0.2)	0.2 (0.1-0.3)	0.25(0.2-0.3)	≤0.5D
			YBG202 YBG205	200 (110-300)	0.1 (0.08-0.2)	0.2 (0.1-0.3)	0.25(0.2-0.3)	≤0.5D
			YBG302	170 (100-280)	0.1 (0.08-0.2)	0.2 (0.1-0.3)	0.25(0.2-0.3)	≤0.5D
K	Cast iron Gusseisen	180-250	YBG102	220 (120-250)	0.1 (0.08-0.2)	0.2 (0.1-0.3)	-	≤0.5D
			YBD152	240 (180-300)	-	0.2 (0.1-0.3)	-	≤0.5D
			YBD252	200 (120-320)	-	0.2 (0.1-0.3)	-	≤0.5D
N	Al alloy Al Leg.	----	-LH					
			YD101	300-	0.2 (0.08-0.4)			≤0.5D
			YD201	300-	0.2 (0.08-0.4)			≤0.5D

Applicable tool B11-B18
Werkzeug

Tools code key B26-B27
Werkzeug ISO

Grade selection guide B19-B23
Sortenauswahl

Technical data B215-B220
Technische Daten

Milling · Fräsen

Indexable Milling Tools · Wendeplattenfräser

2 Slot milling
2 Nutenfräsen

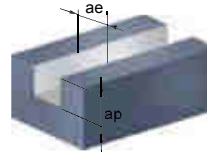

Recommended cutting data · Empfohlene Schnittdaten

Workpiece material Werkstück Material	Hardness HB Härte	Grade Sorte	Cutting data Schnittdaten				
			V(m/min)	f(mm/z)			ae(mm)
				-PF	-PM	-PR	
P Low-carbon steel Soft steel Niedrig legierter Kohlenstoffstahl Baustahl High-carbon steel Alloy steel Hoch Leg. Kohlenstoffstahl Leg. Stahl Alloy tool steel Leg. Werkzeugstahl	≤180	YBM251 YBC301	190 (170-250)	0.1 (0.08-0.15)	0.15 (0.1-0.25)	0.2 (0.2-0.3)	D
		YBM351	150 (130-210)	0.1 (0.08-0.15)	0.15 (0.1-0.25)	0.2 (0.2-0.3)	D
		YBG202 YBG205	190 (140-250)	0.1 (0.08-0.15)	0.15 (0.1-0.25)	0.2 (0.2-0.3)	D
		YBG302	170 (130-250)	0.1 (0.08-0.15)	0.15 (0.1-0.25)	0.2 (0.2-0.3)	D
	180-280	YBM251 YBC301	170 (150-220)	0.1 (0.08-0.15)	0.15 (0.1-0.25)	0.2 (0.2-0.3)	D
		YBM351	140 (110-200)	0.1 (0.08-0.15)	0.15 (0.1-0.25)	0.2 (0.2-0.3)	D
		YBG202 YBG205	170 (130-250)	0.1 (0.08-0.15)	0.15 (0.1-0.25)	0.2 (0.2-0.3)	D
		YBG302	150 (110-230)	0.1 (0.08-0.15)	0.15 (0.1-0.25)	0.2 (0.2-0.3)	D
	280-350	YBM251 YBC301	150 (130-210)	0.1 (0.08-0.15)	0.15 (0.1-0.25)	0.2 (0.2-0.3)	D
		YBM351	130 (100-180)	0.1 (0.08-0.15)	0.15 (0.1-0.25)	0.2 (0.2-0.3)	D
		YBG202 YBG205	150 (110-240)	0.1 (0.08-0.15)	0.15 (0.1-0.25)	0.2 (0.2-0.3)	D
		YBG302	140 (80-210)	0.1 (0.08-0.15)	0.15 (0.1-0.25)	0.2 (0.2-0.3)	D
M Stainless steel Rostfreier Stahl	≤270	YBM251	110 (80-190)	0.1 (0.08-0.15)	0.15 (0.1-0.25)	0.2 (0.2-0.3)	D
		YBM351	100 (80-170)	0.1 (0.08-0.15)	0.15 (0.1-0.25)	0.2 (0.2-0.3)	D
		YBG202 YBG205	120 (80-190)	0.1 (0.08-0.15)	0.15 (0.1-0.25)	0.2 (0.2-0.3)	D
		YBG302	100 (70-180)	0.1 (0.08-0.15)	0.15 (0.1-0.25)	0.2 (0.2-0.3)	D
K Cast iron Gusseisen	180-250	YBG102	130 (80-180)	0.1 (0.08-0.15)	0.15 (0.1-0.25)	-	D
		YBD152	140 (80-210)	-	0.15 (0.1-0.25)	-	D
		YBD252	120 (80-210)	-	0.15 (0.1-0.25)	-	D
N	---	YD101	300-	-LH			D
		YD201	300-	0.2 (0.08-0.3)			D

B

Milling Tools
Fräser

3 Ramp milling, helical interpolation milling 3 Tauchfräsen, Spiral Interpolationsfräsen

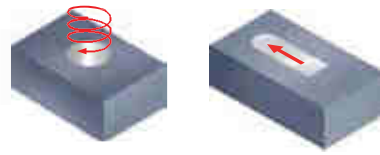

Recommended cutting data · Empfohlene Schnittdaten

<p>● Ramp milling Tauchfräsen</p> $L_m = \frac{a_p}{\tan \alpha}$ <p>(α: Maximum ramp angle) (α: Maximaler Eintauchwinkel)</p>	APKT Ramp milling, helical interpolation milling (Inserts—11) APKT Tauchfräsen, Spiral-Interpolationsfräsen				
	Ramp milling Tauchfräsen			Helical interpolation milling Spiral-Interpolationsfräsen	
	Max. cutting depth Schnitttiefe a_p (mm)	Max. ramp angle Eintauchwinkel α°	Min. length Länge L_m (mm)	Min. diameter Durchmesser $\varnothing D_1$ (mm)	Max. pitch Steigung (mm)
16	10.0	10.0	56.7	20.0	2.0
20	10.0	5.0	114.4	28.0	2.0
25	10.0	4.5	127.0	40.0	2.0
32	10.0	3.0	190.8	56.0	2.0
40	10.0	2.0	286.4	70.0	2.0

<p>● Helical interpolation milling Spiral-Interpolationsfräsen</p> $\tan \alpha = \frac{P}{\pi D_1}$ <p>(α: helical angle) (α: Spiral Winkel)</p>

Milling · Fräsen

Indexable Milling Tools · Wendeplattenfräser

Case study for EMP01
Bearbeitungsbeispiel für EMP01



- Tool · Werkzeug : APKT160408-PM/YBC301
- Inserts · WSP : EMP01-040-XP32-AP16-04

Workpiece material: Cast Steel (HB220)
Werkstück Material:

Cooling system: dry cutting
Kühlsystem: trocken

Machine: vertical machining center
Maschine: vertikales Maschinen-Center

Cutting data:
Schnittdaten:
 $V_c=180\text{m/min}$
 $a_p=3\text{mm}$
 $f_z=0.1\text{mm/z}$

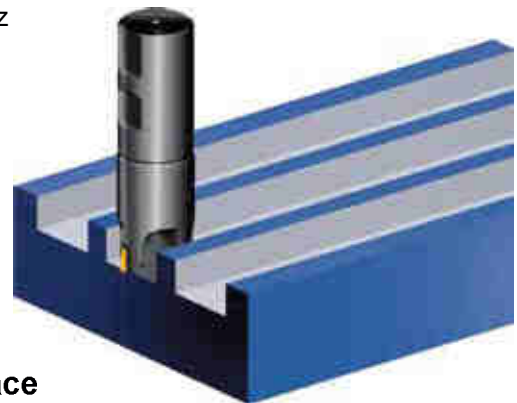

- Wear comparison of insert after milling curved face
- Verschleißvergleich der WSP

ZCC-CT

Produkt of competitor
Wettbewerbsprodukt

15'



25'



B

Milling Tools
Fräser

Square shoulder milling tools · Eckfräser

Kr:90°



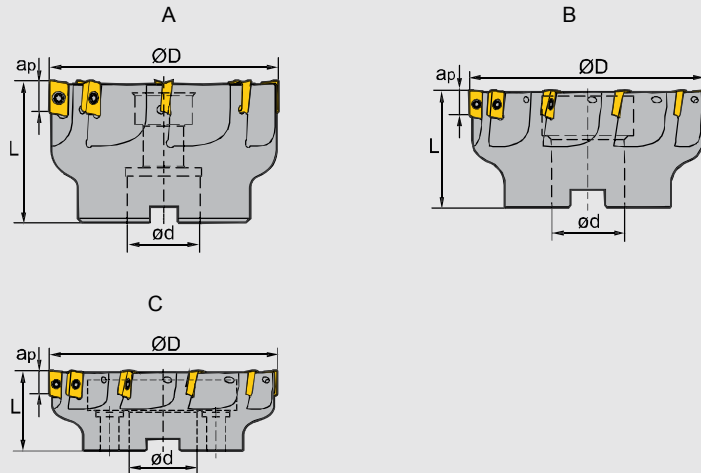

EMP02 P M K N



Specification of tools · Werkzeug Beschreibung

Type Typ	Stock Lager	Dimensions (mm) Abmessungen				No. of teeth Zähne	Coupling Aufnahme	Weight Gewicht (kg)
		Ø D	Ø d	L	apmax			
EMP02 050-A22-AP11-06	●	50	22	40	11	6	A	0.3
050-A22-AP11-06C	●	50	22	40	11	6	A	0.3
063-A22-AP11-08	●	63	22	40	11	8	A	0.6
063-A22-AP11-08C	●	63	22	40	11	8	A	0.6
080-A27-AP11-08	●	80	27	50	11	8	A	1.2
080-A27-AP11-08C	●	80	27	50	11	8	A	1.2
100-B32-AP11-10	●	100	32	50	11	10	B	1.7
100-B32-AP11-10C	●	100	32	50	11	10	B	1.7
050-A22-AP16-05	●	50	22	40	15.5	5	A	0.3
050-A22-AP16-05C	●	50	22	40	15.5	5	A	0.3
063-A22-AP16-06	●	63	22	40	15.5	6	A	0.5
063-A22-AP16-06C	●	63	22	40	15.5	6	A	0.5
080-A27-AP16-07	●	80	27	50	15.5	7	A	1.1
080-A27-AP16-07C	●	80	27	50	15.5	7	A	1.1
100-B32-AP16-08	●	100	32	50	15.5	8	B	1.6
100-B32-AP16-08C	●	100	32	50	15.5	8	B	1.6
125-B40-AP16-10	○	125	40	63	15.5	10	B	3.2
125-B40-AP16-10C	○	125	40	63	15.5	10	B	3.2
160-B40-AP16-10	○	160	40	63	15.5	10	B	6.3
160-B40-AP16-10C	○	160	40	63	15.5	10	B	6.3
200-C60-AP16-12	○	200	60	63	15.5	12	C	8.1
250-C60-AP16-12	○	250	60	63	15.5	12	C	11.2

Spare Parts · Ersatzteile

Diameter Durchmesser Ø D	Insert WSP	Screw Schraube	Wrench Schlüssel	
				
Ø50-Ø250	AP11	I60M2.5×6.5T	WT08IS	
Ø50-Ø250	AP16	I60M4×10	WT15IS	

Applicable tool B11-B18
Werkzeug

Tools code key B26-B27
Werkzeug ISO

Grade selection guide B19-B23
Sortenauswahl

Technical data B215-B220
Technische Daten

B

Milling Tools
Fräser

Milling · Fräsen

Indexable Milling Tools · Wendepplattenfräser

■ Applicable inserts · Wendeschneidplatten

- Ideal Machining Condition / Gute Bearbeitungsbedingungen
- Normal Machining Condition / Normale Bearbeitungsbedingungen
- Unfavorable Machining Condition / Ungünstige Bearbeitungsbedingungen

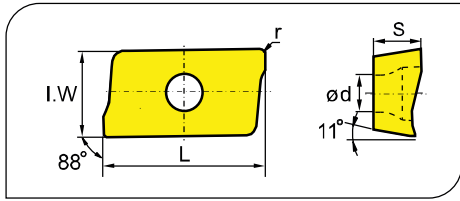

Workpiece Material / Werkstoffe	P	M	K	N	S
Steel / Stahl	●	●	●	●	●
Stainless Steel / Rostfreier Stahl	●	●	●	●	●
Cast iron / Gusseisen	●	●	●	●	●
Non-ferrous material / <i>Ne Metalle</i>	●	●	●	●	●
Heat-resistant steel / Warmfester Stahl	●	●	●	●	●

Insert shape / Plattenform	Type / Typ	Dimensions (mm) / Abmessungen					CVD Coating / CVD Beschicht.						PVD Coating / PVD Beschicht.				Cemet / Cemet	Carbide uncoat. / unbe. Hartmetall								
		L	I.W	S	d	r	YBC301	YBC302	YBC401	YBM251	YBM253	YBM351	YBD152	YBD252	YBG102	YBG202		YBG205	YBG302	YBG152	YBG252	YNG151	YNG151C	YC30S	YD101	YD201
	APKT11T304-PF	12.24	6.5	3.6	2.8	0.4	○		●						●	●	●									
	APKT11T308-PF	12.24	6.5	3.6	2.8	0.8				○						●										
	APKT11T312-PF	12.24	6.5	3.6	2.8	1.2										○										
	APKT11T316-PF	12.24	6.5	3.6	2.8	1.6										○										
	APKT11T304-PM	12.24	6.5	3.6	2.8	0.4	●	●	●	●	●				●	●	●									
	APKT11T308-PM	12.24	6.5	3.6	2.8	0.8	●	●		●	●	●	●	●	●	●	●	●								
	APKT11T312-PM	12.24	6.5	3.6	2.8	1.2				○					○	●										
	APKT11T316-PM	12.24	6.5	3.6	2.8	1.6				●					○	●										
	APKT11T304-PR	12.24	6.5	3.6	2.8	0.4			●		○						○									
	APKT11T308-PR	12.24	6.5	3.6	2.8	0.4											○									
	APKT11T312-PR	12.24	6.5	3.6	2.8	0.4											○									
	APKT11T316-PR	12.24	6.5	3.6	2.8	0.4											○									
	APKT160408-PR	17.877	9.33	5.76	4.4	0.8											○									
	APKT11T304-LH	12.24	6.5	3.6	2.8	0.4																	●	●		
	APKT11T308-LH	12.24	6.5	3.6	2.8	0.8																	●	●		
	APET160402-LH	17.877	9.33	5.76	4.4	0.2																		○		
	APKT160408-LH	17.877	9.33	5.76	4.4	0.8																	●	●		
	APET160408PDR-LH	17.877	9.33	5.76	4.4	0.8																	○			

● Ex Stock / ab Lager ○ On demand / auf Anfrage

Chipbreaker Selection - Spanbrecher Auswahl

Application Anwendung	Finishing Schlichten	Semi-Finishing Mittlere Bearbeitung	Roughing Schruppen
P	-PF	-PM	-PR
M	-PF	-PM	-PR
K	-PF	-PM	
AL	-LH		

Square shoulder milling Eckfräsen

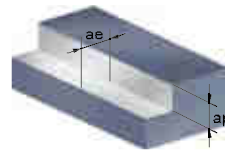

Recommended cutting data - Empfohlene Schnittdaten

Workpiece material Werkstück Material	Hardness HB Härte	Grade Sorte	Cutting data Schnittdaten					
			V(m/min)	f(mm/z)			ae(mm)	
				-PF	-PM	-PR		
P	Low-carbon steel Soft steel Niedrig legierter Kohlenstoffstahl Baustahl	YBM251	320 (240-400)	0.1 (0.08-0.2)	0.2 (0.1-0.3)	0.25(0.2-0.35)	≤0.5D	
		YBC301	260 (180-380)	0.1 (0.08-0.2)	0.2 (0.1-0.3)	0.25(0.2-0.35)	≤0.5D	
		YBG202	320 (200-400)	0.1 (0.08-0.2)	0.2 (0.1-0.3)	0.25(0.2-0.35)	≤0.5D	
		YBG205	280 (180-400)	0.1 (0.08-0.2)	0.2 (0.1-0.3)	0.25(0.2-0.35)	≤0.5D	
	High-carbon steel Alloy steel Hoch Leg. Kohlenstoffstahl Leg. Stahl	YBM251	280 (210-380)	0.1 (0.08-0.2)	0.2 (0.1-0.3)	0.25(0.2-0.3)	≤0.5D	
		YBC301	240 (160-320)	0.1 (0.08-0.2)	0.2 (0.1-0.3)	0.25(0.2-0.35)	≤0.5D	
		YBG202	280 (180-350)	0.1 (0.08-0.2)	0.2 (0.1-0.3)	0.25(0.2-0.3)	≤0.5D	
		YBG205	260 (150-380)	0.1 (0.08-0.2)	0.2 (0.1-0.3)	0.25(0.2-0.35)	≤0.5D	
	Alloy tool steel Leg. Werkzeugstahl	YBM251	260 (180-350)	0.1 (0.08-0.2)	0.2 (0.1-0.3)	0.25(0.2-0.3)	≤0.5D	
		YBC301	220 (150-280)	0.1 (0.08-0.2)	0.2 (0.1-0.3)	0.25(0.2-0.35)	≤0.5D	
		YBG202	260 (160-330)	0.1 (0.08-0.2)	0.2 (0.1-0.3)	0.25(0.2-0.3)	≤0.5D	
		YBG302	240 (120-350)	0.1 (0.08-0.2)	0.2 (0.1-0.3)	0.25(0.2-0.35)	≤0.5D	
M	Stainless steel Rostfreier Stahl	YBM251	200 (120-270)	0.1 (0.08-0.2)	0.2 (0.1-0.3)	0.25(0.2-0.3)	≤0.5D	
		YBM351	180 (150-300)	0.1 (0.08-0.2)	0.2 (0.1-0.3)	0.25(0.2-0.3)	≤0.5D	
		YBG202	200 (110-300)	0.1 (0.08-0.2)	0.2 (0.1-0.3)	0.25(0.2-0.3)	≤0.5D	
		YBG302	170 (100-280)	0.1 (0.08-0.2)	0.2 (0.1-0.3)	0.25(0.2-0.3)	≤0.5D	
K	Cast iron Gusseisen	YBG102	220 (120-250)	0.1 (0.08-0.2)	0.2 (0.1-0.3)	-	≤0.5D	
		YBD152	240 (180-300)	-	0.2 (0.1-0.3)	-	≤0.5D	
		YBD252	200 (120-320)	-	0.2 (0.1-0.3)	-	≤0.5D	
N				-LH				
	Al alloy Al Leg.	---	YD101	300-	0.2 (0.08-0.4)			≤0.5D
			YD201	300-	0.2 (0.08-0.4)			≤0.5D

Applicable tool B11-B18
Werkzeug

Tools code key B26-B27
Werkzeug ISO

Grade selection guide B19-B23
Sortenauswahl

Technical data B215-B220
Technische Daten

Milling · Fräsen

Indexable Milling Tools · Wendeplattenfräser

Square shoulder milling tools · Eckfräser

Kr:90°



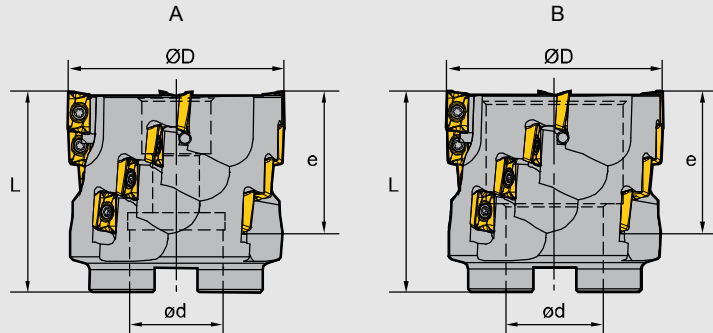

EMPO3 P M K N



Specification of tools · Werkzeug Beschreibung

Type Typ	Stock Lager	Dimensions (mm) Abmessungen				Flute number Zahn- reihen z	No. of inserts WSP Anzahl	Coupling Aufnahme	Weight Gewicht (kg)
		Ø D	Ø d	L	e				
EMPO3 -050-A22-AP11-04	●	50	22	58	39	4	16	A	0.5
-050-A22-AP11-04C	●	50	22	58	39	4	16	A	0.5
-063-A27-AP11-04	●	63	27	58	39	4	16	A	0.9
-063-A27-AP11-04C	●	63	27	58	39	4	16	A	0.9
-080-B32-AP11-05	●	80	32	63	39	5	20	B	1.3
-080-B32-AP11-05C	●	80	32	63	39	5	20	B	1.3
-100-B40-AP11-06	○	100	40	63	39	6	24	B	2.0
-100-B40-AP11-06C	○	100	40	63	39	6	24	B	2.0

Spare Parts · Ersatzteile

Diameter Durchmesser Ø D	Screw Schraube	Wrench Schlüssel	
			
Ø50-Ø100	I60M2.5×6.5T	WT08IS	

● Ex Stock / ab Lager ○ On demand / auf Anfrage

Square shoulder milling tools · Eckfräser

Kr:90°



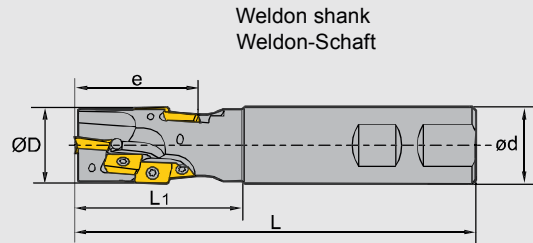

EMP04 P M K N



Specification of tools · Werkzeug Beschreibung

Type Typ	Stock Lager	Dimensions (mm) Abmessungen					Flute number Zahn- reihen z	No. of inserts WSP Anzahl	Weight Gewicht (kg)
		Ø D	Ø d	L	L1	e			
EMP04 -020-XP20-AP11-01	●	20	20	120	45	29.4	1	3	0.3
-020-XP20-AP11-01C	●	20	20	120	45	29.4	1	3	0.3
-025-XP25-AP11-02	●	25	25	130	55	38.9	2	8	0.4
-025-XP25-AP11-02C	●	25	25	130	55	38.9	2	8	0.4
-032-XP32-AP11-02	●	32	32	140	65	48.5	2	10	0.7
-032-XP32-AP11-02C	●	32	32	140	65	48.5	2	10	0.7
-040-XP40-AP11-02	●	40	40	150	75	58.0	2	14	1.3
-040-XP40-AP11-02C	●	40	40	150	75	58.0	2	14	1.3

Spare Parts · Ersatzteile

Diameter Durchmesser Ø D	Screw Schraube	Wrench Schlüssel
Ø20-Ø40	 I60M2.5×6.5T	 WT08IS

Applicable tool B11-B18
Werkzeug

Tools code key B26-B27
Werkzeug ISO

Grade selection guide B19-B23
Sortenauswahl

Technical data B215-B220
Technische Daten

Milling · Fräsen

Indexable Milling Tools · Wendepplattenfräser

■ Applicable inserts · Wendeschneidplatten

● Ideal Machining Condition / Gute Bearbeitungsbedingungen
 ● Normal Machining Condition / Normale Bearbeitungsbedingungen
 ● Unfavorable Machining Condition / Ungünstige Bearbeitungsbedingungen

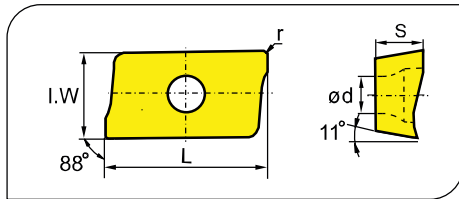

Workpiece Material / Werkstoffe	P	M	K	N	S
Steel / Stahl	●	●	●	●	●
Stainless Steel / Rostfreier Stahl	●	●	●	●	●
Cast iron / Gusseisen	●	●	●	●	●
Non-ferrous material / Ne Metalle	●	●	●	●	●
Heat-resistant steel / Warmfester Stahl	●	●	●	●	●

Insert shape / Plattenform	Type / Typ	Dimensions (mm) / Abmessungen					CVD Coating / CVD Beschicht.						PVD Coating / PVD Beschicht.				Cemet / Cemet		Carbide uncoat. / unbe. Hartmetall							
		L	I.W	S	d	r	YBC301	YBC302	YBC401	YBM251	YBM253	YBM351	YBD152	YBD252	YBG102	YBG202	YBG205	YBG302	YBG152	YBG252	YNG151	YNG151C	YC30S	YD101	YD201	
	APKT11T304-PF	12.24	6.5	3.6	2.8	0.4	○		●					●	●		●									
	APKT11T308-PF	12.24	6.5	3.6	2.8	0.8			○						●											
	APKT11T312-PF	12.24	6.5	3.6	2.8	1.2									○											
	APKT11T316-PF	12.24	6.5	3.6	2.8	1.6									○											
	APKT11T304-PM	12.24	6.5	3.6	2.8	0.4	●	●	○	●	●			●	●		●									
	APKT11T308-PM	12.24	6.5	3.6	2.8	0.8	●	●		●	●	●	●	●	●	●	●	●								
	APKT11T312-PM	12.24	6.5	3.6	2.8	1.2				○				○	●											
	APKT11T316-PM	12.24	6.5	3.6	2.8	1.6				●				○	●											
	APKT11T304-PR	12.24	6.5	3.6	2.8	0.4			●			○						○								
	APKT11T308-PR	12.24	6.5	3.6	2.8	0.4												○								
	APKT11T312-PR	12.24	6.5	3.6	2.8	0.4												○								
	APKT11T316-PR	12.24	6.5	3.6	2.8	0.4												○								
	APKT11T304-LH	12.24	6.5	3.6	2.8	0.4																	●	●		
	APKT11T308-LH	12.24	6.5	3.6	2.8	0.8																	●	●		
	APKT160408-LH	17.877	9.33	5.76	4.4	0.8																	●	●		

■ Chipbreaker Selection · Spanbrecher Auswahl

Application / Anwendung	Finishing / Schichten	Semi-Finishing / Mittlere Bearbeitung	Roughing / Schruppen
P	-PF	-PM	-PR
M	-PF	-PM	-PR
K	-PF	-PM	
AL	-LH		

● Ex Stock / ab Lager ○ On demand / auf Anfrage

Recommended cutting data · Empfohlene Schnittdaten

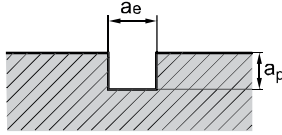
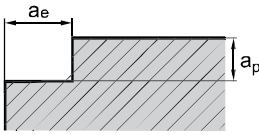
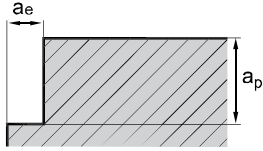
Slot milling Nutenfräsen	Square shoulder milling Eckfräsen	Deep square shoulder milling Tiefes Eckfräsen
		
ae=D ap≤0.5D	ae:≤0.5D ap:≤1.2D	ae:≤0.2D ap<Cutting length of insert Schneidkantenlänge

Workpiece material Werkstück Material	Hardness HB Härte	Grade Sorte	Cutting data Schnittdaten				
			Square shoulder milling Eckfräsen				
			V(m/min)	f(mm/z)			
-PF	-PM	-PR					
P Low-carbon steel Soft steel Niedrig legierter Kohlenstoffstahl Baustahl	≤180	YBM251 YBC301	270 (240-350)	0.1 (0.08-0.2)	0.2 (0.1-0.3)	0.25(0.2-0.35)	
		YBM351	220 (180-300)	0.1 (0.08-0.2)	0.2 (0.1-0.3)	0.25(0.2-0.35)	
		YBG202 YBG205	270 (200-360)	0.1 (0.08-0.2)	0.2 (0.1-0.3)	0.25(0.2-0.35)	
		YBG302	240 (180-350)	0.1 (0.08-0.2)	0.2 (0.1-0.3)	0.25(0.2-0.35)	
	High-carbon steel Alloy steel Hoch Leg. Kohlenstoffstahl Leg. Stahl	180-280	YBM251 YBC301	240 (210-320)	0.1 (0.08-0.2)	0.2 (0.1-0.3)	0.25(0.2-0.35)
			YBM351	200 (160-280)	0.1 (0.08-0.2)	0.2 (0.1-0.3)	0.25(0.2-0.35)
			YBG202 YBG205	240 (180-360)	0.1 (0.08-0.2)	0.2 (0.1-0.3)	0.25(0.2-0.35)
			YBG302	220 (150-330)	0.1 (0.08-0.2)	0.2 (0.1-0.3)	0.25(0.2-0.35)
	Alloy tool steel Leg. Werkzeugstahl	280-350	YBM251 YBC301	220 (180-300)	0.1 (0.08-0.2)	0.2 (0.1-0.3)	0.25(0.2-0.35)
			YBM351	180 (150-250)	0.1 (0.08-0.2)	0.2 (0.1-0.3)	0.25(0.2-0.35)
			YBG202 YBG205	220 (160-340)	0.1 (0.08-0.2)	0.2 (0.1-0.3)	0.25(0.2-0.35)
			YBG302	200 (120-300)	0.1 (0.08-0.2)	0.2 (0.1-0.3)	0.25(0.2-0.35)
M Stainless steel Rostfreier Stahl	≤270	YBM251	170 (120-240)	0.1 (0.08-0.2)	0.2 (0.1-0.3)	0.25(0.2-0.35)	
		YBM351	160 (150-270)	0.1 (0.08-0.2)	0.2 (0.1-0.3)	0.25(0.2-0.35)	
		YBG202 YBG205	150 (110-270)	0.1 (0.08-0.2)	0.2 (0.1-0.3)	0.25(0.2-0.35)	
		YBG302	140 (100-250)	0.1 (0.08-0.2)	0.2 (0.1-0.3)	0.25(0.2-0.35)	
K Cast iron Gusseisen	180-250	YBG102	200 (120-240)	0.1 (0.08-0.2)	0.2 (0.1-0.3)	-	
		YBD152	240 (180-300)	0.1 (0.08-0.2)	0.2 (0.1-0.3)	-	
		YBD252	180 (120-300)	-	0.2 (0.1-0.3)	-	
N Al alloy Al Leg.	---	YD101	300-	-LH 0.2 (0.08-0.4)			
		YD201	300-	0.2 (0.08-0.4)			

Applicable tool B11-B18
Werkzeug

Tools code key B26-B27
Werkzeug ISO

Grade selection guide B19-B23
Sortenauswahl

Technical data B215-B220
Technische Daten

Milling · Fräsen

Indexable Milling Tools · Wendeplattenfräser

Recommended cutting data · Empfohlene Schnittdaten

Workpiece material Werkstück Material	Hardness HB Härte	Grade Sorte	Cutting data Schnittdaten				
			Slot milling, deep square shoulder milling Nutenfräsen, Eckfräsen				
			V(m/min)	f(mm/z)			
-PF	-PM	-PR					
P Low-carbon steel Soft steel Niedrig legierter Kohlenstoffstahl Baustahl	≤180	YBM251 YBC301	270 (240-350)	0.1 (0.08-0.15)	0.15 (0.1-0.25)	0.2 (0.2-0.3)	
		YBM351	220 (180-300)	0.1 (0.08-0.15)	0.15 (0.1-0.25)	0.2 (0.2-0.3)	
		YBG202 YBG205	270 (200-360)	0.1 (0.08-0.15)	0.15 (0.1-0.25)	0.2 (0.2-0.3)	
		YBG302	240 (180-350)	0.1 (0.08-0.15)	0.15 (0.1-0.25)	0.2 (0.2-0.3)	
	High-carbon steel Alloy steel Hoch Leg. Kohlenstoffstahl Leg. Stahl	180-280	YBM251 YBC301	240 (210-320)	0.1 (0.08-0.15)	0.15 (0.1-0.25)	0.2 (0.2-0.3)
			YBM351	200 (160-280)	0.1 (0.08-0.15)	0.15 (0.1-0.25)	0.2 (0.2-0.3)
			YBG202 YBG205	240 (180-360)	0.1 (0.08-0.15)	0.15 (0.1-0.25)	0.2 (0.2-0.3)
			YBG302	220 (150-330)	0.1 (0.08-0.15)	0.15 (0.1-0.25)	0.2 (0.2-0.3)
	Alloy tool steel Leg. Werkzeugstahl	280-350	YBM251 YBC301	220 (180-300)	0.1 (0.08-0.15)	0.15 (0.1-0.25)	0.2 (0.2-0.3)
			YBM351	180 (150-250)	0.1 (0.08-0.15)	0.15 (0.1-0.25)	0.2 (0.2-0.3)
			YBG202 YBG205	220 (160-340)	0.1 (0.08-0.15)	0.15 (0.1-0.25)	0.2 (0.2-0.3)
			YBG302	200 (120-300)	0.1 (0.08-0.15)	0.15 (0.1-0.25)	0.2 (0.2-0.3)
M Stainless steel Rostfreier Stahl	≤270	YBM251	170 (120-240)	0.1 (0.08-0.15)	0.15 (0.1-0.25)	0.2 (0.2-0.3)	
		YBM351	160 (150-270)	0.1 (0.08-0.15)	0.15 (0.1-0.25)	0.2 (0.2-0.3)	
		YBG202 YBG205	150 (110-270)	0.1 (0.08-0.15)	0.15 (0.1-0.25)	0.2 (0.2-0.3)	
		YBG302	140 (100-250)	0.1 (0.08-0.15)	0.15 (0.1-0.25)	0.2 (0.2-0.3)	
K Cast iron Gusseisen	180-250	YBG102	200 (120-240)	0.1 (0.08-0.15)	0.15 (0.1-0.25)	-	
		YBD152	240 (180-300)	0.1 (0.08-0.15)	0.15 (0.1-0.25)	-	
		YBD252	180 (120-300)	-	0.15 (0.1-0.25)	-	
N				-LH			
	Al alloy Al Leg.	----	YD101	300-	0.2 (0.08-0.3)		
			YD201	300-	0.2 (0.08-0.3)		

B

Milling Tools
Fräser

Square shoulder milling tools · Eckfräser

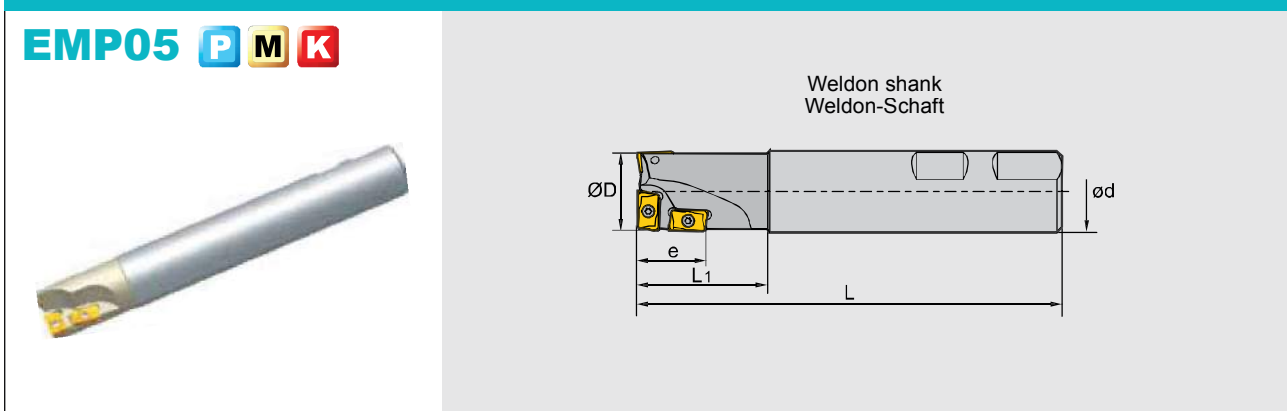

Kr:90°



Specification of tools · Werkzeug Beschreibung

Type Typ	Stock Lager	Dimensions (mm) Abmessungen					No. of inserts WSP Anzahl		Weight Gewicht (kg)	
		R	Ø D	Ø d	L	L ₁	e	APMT11		APMT16
EMP05	-025-XP25	●	25	25	130	40	20	3	--	0.5
	-025-XP25C	●	25	25	130	40	20	3	--	0.5
	-032-XP32	●	32	32	140	50	30	--	3	0.8
	-032-XP32C	●	32	32	140	50	30	--	3	0.8
	-040-XP32	●	40	32	150	60	40	--	4	1.0
	-040-XP32C	●	40	32	150	60	40	--	4	1.0

Spare Parts · Ersatzteile

Diameter Durchmesser Ø D	Insert WSP	Screw Schraube	Wrench Schlüssel	
				
Ø25-Ø40	APMT11	I60M2.5×6.5T	WT08IP	
	APMT16	I60M4×10	WT15IP	

Applicable tool B11-B18
Werkzeug

Tools code key B26-B27
Werkzeug ISO

Grade selection guide B19-B23
Sortenauswahl

Technical data B215-B220
Technische Daten

Milling · Fräsen

Indexable Milling Tools · Wendeplattenfräser

■ Applicable inserts · Wendschneidplatten

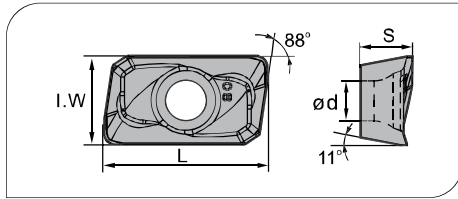

Workpiece Material Werkstoff	Ideal Machining Condition Gute Bearbeitungsbedingungen		Normal Machining Condition Normale Bearbeitungsbedingungen		Unfavorable Machining Condition Ungünstige Bearbeitungsbedingungen	
	●	●	●	●	●	●
P Steel Stahl	●	●	●	●	●	●
M Stainless Steel Rostfreier Stahl	●	●	●	●	●	●
K Cast iron Gusseisen	●	●	●	●	●	●
N Non-ferrous material Nichtmetalle	●	●	●	●	●	●
S Heat-resistant steel Wärmefester Stahl	●	●	●	●	●	●

Insert shape Plattenform	Type Typ	Dimensions (mm) Abmessungen					CVD Coating CVD Beschicht.						PVD Coating PVD Beschicht.				Cemet Cemet	Carbide uncoat. unbe. Hartmetall								
		L	I.W	S	d	r	YBC301	YBC302	YBC401	YBM251	YBM253	YBM351	YBD152	YBD252	YBG102	YBG202		YBG205	YBG302	YBG152	YBG252	YNG151	YNG151C	YC30S	YD101	YD201
	APMT1135PDR	11.25	6.2	3.5	2.8	0.8				○					○	○	●									
	APMT160408PDER	17.25	9.25	4.76	4.4	0.8				○	○				○	●										

1 Drilling Bohren



■ Recommended cutting data · Empfohlene Schnittdaten

	Workpiece material Werkstück Material	Hardness HB Härte	Grade Sorte	Cutting data · Schnittdaten	
				V(m/min)	f(mm/z)
P	Low-carbon steel Soft steel Niedrig legierter Kohlenstoffstahl Baustahl	≤180	YBG202 YBG205	180 (150-220)	0.2 (0.08-0.25)
	High-carbon steel Alloy steel Hoch Leg. Kohlenstoffstahl	180-280	YBG202 YBG205	160 (130-200)	0.15 (0.08-0.2)
	Alloy tool steel Leg. Werkzeugstahl	280-350	YBG202 YBG205	140 (120-180)	0.12 (0.05-0.2)
M	Stainless steel Rostfreier Stahl	≤270	YBG202 YBG205	80 (50-150)	0.08 (0.03-0.15)
K	Cast iron Gusseisen	180-250	YBG202 YBG205	150 (100-220)	0.15 (0.08-0.2)

2 Milling Fräsen

■ Recommended cutting data · Empfohlene Schnittdaten

	Workpiece material Werkstück Material	Hardness HB Härte	Grade Sorte	Cutting data · Schnittdaten	
				V(m/min)	f(mm/z)
P	Low-carbon steel Soft steel Niedrig legierter Kohlenstoffstahl Baustahl	≤180	YBG202 YBG205	190 (140-250)	0.08 (0.04-0.15)
	High-carbon steel Alloy steel Hoch leg. Kohlenstoffstahl	180-280	YBG202 YBG205	170 (130-250)	0.08 (0.04-0.15)
	Alloy tool steel Leg. Werkzeugstahl	280-350	YBG202 YBG205	150 (110-240)	0.08 (0.04-0.15)
M	Stainless steel Rostfreier Stahl	≤270	YBG202 YBG205	120 (80-190)	0.08 (0.04-0.15)
K	Cast iron Gusseisen	180-250	YBG202 YBG205	120 (80-210)	0.08 (0.04-0.15)

● Ex Stock / ab Lager ○ On demand / auf Anfrage

Profile milling tools · Profilfräser



BMR01 P M K

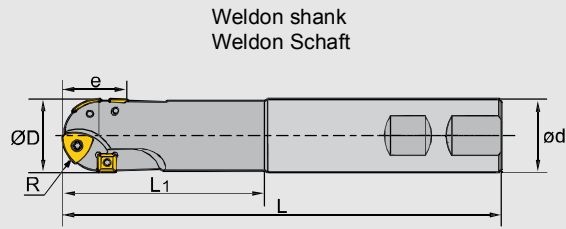



Specification of tools · Werkzeug Beschreibung

Type Typ	Stock Lager	Dimensions (mm) Abmessungen							Inserts WSP				Weight Gewicht (kg)	
		R	Ø D	e	ø d	L	L ₁	Type Typ	Quantity Anzahl	Type Typ	Quantity Anzahl			
BMR01														
-020-XP20-S	○	10	20	20	20	125	50	ZDET08T2CYR10	2	SPMT060304	2	0.3		
-020-XP20-M	○	10	20	20	20	150	75	ZDET08T2CYR10	2	SPMT060304	2	0.3		
-020-XP20-L	○	10	20	20	20	200	100	ZDET08T2CYR10	2	SPMT060304	2	0.4		
-025-XP25-S	○	12.5	25	23	25	150	70	ZDET1103CYR12.5	2	SPMT060304	2	0.5		
-025-XP25-M	●	12.5	25	23	25	175	95	ZDET1103CYR12.5	2	SPMT060304	2	0.6		
-025-XP25-L	○	12.5	25	23	25	200	100	ZDET1103CYR12.5	2	SPMT060304	2	0.7		
-032-XP32-S	○	16	32	31	32	175	85	ZDET13T3CYR16	2	SDMT090308	2	0.9		
-032-XP32-M	○	16	32	31	32	200	100	ZDET13T3CYR16	2	SDMT090308	2	1.1		
-032-XP32-L	○	16	32	31	32	250	150	ZDET13T3CYR16	2	SDMT090308	2	1.4		
-040-XP40-S	○	20	40	41	40	175	85	ZPNT2204CY(R20)	3	SPMT120408	2	1.4		
-040-XP40-M	○	20	40	41	40	200	100	ZPNT2204CY(R20)	3	SPMT120408	2	1.7		
-040-XP40-L	○	20	40	41	40	250	150	ZPNT2204CY(R20)	3	SPMT120408	2	2.1		
-050-XP40-S	○	25	50	45	40	200	100	ZPNT2204CY(R25)	3	SPMT120408	2	1.8		
-050-XP40-M	○	25	50	45	40	300	100	ZPNT2204CY(R25)	3	SPMT120408	2	2.8		
-063-XP40-S	○	31.5	63	52	40	200	100	ZPNT2204CY(R31)	4	SPMT120408	2	3.0		
-063-XP40-M	○	31.5	63	52	40	300	100	ZPNT2204CY(R31)	4	SPMT120408	2	3.5		

● Ex Stock / ab Lager ○ On demand / auf Anfrage

Spare parts · Ersatzteile

Diameter Durchmesser Ø D	Screw Schraube	Wrench Schlüssel	
			
Ø20-Ø25	I43M2.5×5.7	WT07IP	--
Ø32	I43M4×8	--	WT15IS
Ø40-Ø63	I43M5×11	--	WT20IS



Applicable tool B11-B18
Werkzeug

Tools code key B26-B27
Werkzeug ISO

Grade selection guide B19-B23
Sortenauswahl

Technical data B215-B220
Technische Daten

Milling - Fräsen

Indexable Milling Tools - Wendepplattenfräser

Applicable inserts - Wendeschneidplatten

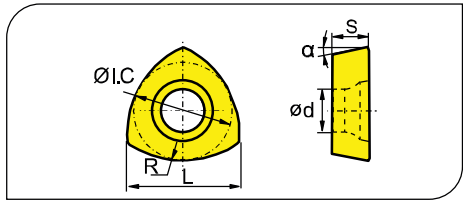

● Ideal Machining Condition / Gute Bearbeitungsbedingungen
● Normal Machining Condition / Normale Bearbeitungsbedingungen
● Unfavorable Machining Condition / Ungünstige Bearbeitungsbedingungen

Workpiece Material / Werkstoffe	P	M	K	N	S	YBC301	YBC302	YBC401	YBM251	YBM253	YBM351	YBD152	YBD252	YBG102	YBG202	YBG205	YBG302	YBG152	YBG252	YNG151	YNG151C	YC30S	YD101	YD201
P Steel / Stahl	●	●	●	●	●	●	●	●	●	●	●	●	●	●	●	●	●	●	●	●	●	●	●	●
M Stainless Steel / Rostfreier Stahl	●	●	●	●	●	●	●	●	●	●	●	●	●	●	●	●	●	●	●	●	●	●	●	●
K Cast iron / Gusseisen	●	●	●	●	●	●	●	●	●	●	●	●	●	●	●	●	●	●	●	●	●	●	●	●
N Non-ferrous material / Ne Metalle	●	●	●	●	●	●	●	●	●	●	●	●	●	●	●	●	●	●	●	●	●	●	●	●
S Heat-resistant steel / Warmfester Stahl	●	●	●	●	●	●	●	●	●	●	●	●	●	●	●	●	●	●	●	●	●	●	●	●

Insert WSP	Type Typ	Dimensions (mm) / Abmessungen						CVD Coating / CVD Beschicht.						PVD Coating / PVD Beschicht.				Cermet / Cermet	Carbide uncoat / unbee. Hartmetall						
		R	L	I.C.	S	d	α	YBC301	YBC302	YBC401	YBM251	YBM253	YBM351	YBD152	YBD252	YBG102	YBG202		YBG205	YBG302	YBG152	YBG252	YNG151	YNG151C	YC30S
	ZDET08T2CYR10	10	8.4	6.75	2.78	2.8	14°				●														
	ZDET1103CYR12.5	12.5	10.6	8.5	3.18	2.8	14°				●														
	ZDET13T3CYR16	16	13.2	10.5	3.97	4.4	14°				●														
	ZPNT2204CY(R20)	20	16.1	12.7	4.76	5.56	11°				○														
	ZPNT2204CY(R25)	25	16.9	12.7	4.76	5.56	11°				●														
	ZPNT2204CY(R31)	31.5	17.6	12.7	4.76	5.56	11°				●														

Applicable inserts - Wendeschneidplatten

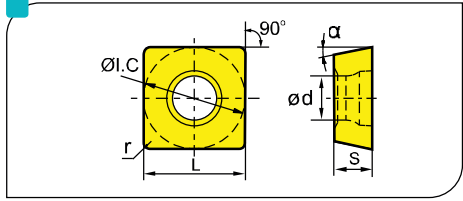

● Ideal Machining Condition / Gute Bearbeitungsbedingungen
● Normal Machining Condition / Normale Bearbeitungsbedingungen
● Unfavorable Machining Condition / Ungünstige Bearbeitungsbedingungen

Workpiece Material / Werkstoffe	P	M	K	N	S	YBC301	YBC302	YBC401	YBM251	YBM253	YBM351	YBD152	YBD252	YBG102	YBG202	YBG205	YBG302	YBG152	YBG252	YNG151	YNG151C	YC30S	YD101	YD201
P Steel / Stahl	●	●	●	●	●	●	●	●	●	●	●	●	●	●	●	●	●	●	●	●	●	●	●	●
M Stainless Steel / Rostfreier Stahl	●	●	●	●	●	●	●	●	●	●	●	●	●	●	●	●	●	●	●	●	●	●	●	●
K Cast iron / Gusseisen	●	●	●	●	●	●	●	●	●	●	●	●	●	●	●	●	●	●	●	●	●	●	●	●
N Non-ferrous material / Ne Metalle	●	●	●	●	●	●	●	●	●	●	●	●	●	●	●	●	●	●	●	●	●	●	●	●
S Heat-resistant steel / Warmfester Stahl	●	●	●	●	●	●	●	●	●	●	●	●	●	●	●	●	●	●	●	●	●	●	●	●

Insert WSP	Type Typ	Dimensions (mm) / Abmessungen						CVD Coating / CVD Beschicht.						PVD Coating / PVD Beschicht.				Cermet / Cermet	Carbide uncoat / unbee. Hartmetall						
		r	L	I.C.	S	d	α	YBC301	YBC302	YBC401	YBM251	YBM253	YBM351	YBD152	YBD252	YBG102	YBG202		YBG205	YBG302	YBG152	YBG252	YNG151	YNG151C	YC30S
	SPMT060304	0.4	6.35	6.35	3.18	2.8	11°				●														
	SDMT090308	0.8	9.525	9.525	3.18	4.4	15°				●	○													
	SPMT120408	0.8	12.7	12.70	4.76	5.5	11°	●	○	●															

Recommended Cutting data - Schnittdaten

Workpiece material / Werkstückstoff	Hardness HB / Härte	Grade / Sorte	Cutting data / Schnittdaten	
			V(m/min)	f(mm/z)
P Low-carbon steel / Soft steel / Niedriglegierter Kohlenstoffstahl / Baustahl High-carbon steel / Alloy steel / Hochleg. Kohlenstoffstahl / Leg. Stahl	≤180	YBM251 YBC301	180(120-220)	0.25(0.1-0.4)
		YBG302 YBC401	160(120-220)	0.25(0.1-0.4)
	180-280	YBM251 YBC301	150(100-200)	0.2(0.1-0.4)
		YBG302 YBC401	120(100-200)	0.2(0.1-0.4)
280-350	YBM251 YBC301	100(80-150)	0.2(0.1-0.3)	
	YBG302	100(80-150)	0.2(0.1-0.3)	
M Stainless steel / Rostfreier Stahl	≤270	YBM251	100(80-150)	0.2(0.1-0.3)
		YBG302 YBC401	100(80-150)	0.2(0.1-0.3)
K Cast iron / Gusseisen	180-250	YBM251	150(100-180)	0.3(0.2-0.5)

● Ex Stock / ab Lager ○ On demand / auf Anfrage



Profile milling tools · Profilfräser

BMR02 P M K

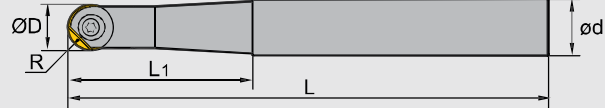

Specification of tools · Werkzeug Beschreibung

	Type Typ	Stock Lager	Dimensions (mm) Abmessungen					Weight Gewicht (kg)
			R	Ø D	ø d	L	L ₁	
BMR02	-012-G16-S	●	6	12	16	110	40	0.1
	-012-G16-M	●	6	12	16	130	50	0.2
	-012-G16-L	●	6	12	16	160	50	0.2
	-016-G20-S	●	8	16	20	140	45	0.3
	-016-G20-M	●	8	16	20	170	65	0.3
	-016-G20-L	●	8	16	20	200	65	0.4
	-020-G25-S	●	10	20	25	160	60	0.5
	-020-G25-M	●	10	20	25	200	80	0.6
	-020-G25-L	●	10	20	25	240	80	0.8

● Ex Stock / ab Lager ○ On demand / auf Anfrage

Spare parts · Ersatzteile

Diameter Durchmesser Ø D	Screw Schraube	Wrench Schlüssel
Ø12	I90M4×09TT	WT10S
Ø16	I90M5×11TT	WT15S
Ø20	I90M5×13.5TT	WT15S



Applicable tool B11-B18
Werkzeug

Tools code key B26-B27
Werkzeug ISO

Grade selection guide B19-B23
Sortenauswahl

Technical data B215-B220
Technische Daten

Milling - Fräsen

Indexable Milling Tools - Wendepplattenfräser

Applicable inserts - Wendschneidplatten

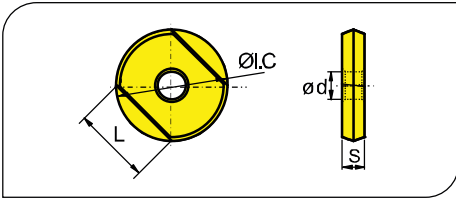

- Ideal Machining Condition / Gute Bearbeitungsbedingungen
- Normal Machining Condition / Normale Bearbeitungsbedingungen
- Unfavorable Machining Condition / Ungünstige Bearbeitungsbedingungen

Workpiece Material / Werkstoffe	P	M	K	N	S
P Steel / Stahl	●	●	●	●	●
M Stainless Steel / Rostfreier Stahl	●	●	●	●	●
K Cast iron / Gusseisen	●	●	●	●	●
N Non-ferrous material / Ne Metalle	●	●	●	●	●
S Heat-resistant steel / Warmfester Stahl	●	●	●	●	●

Insert WSP	Type Typ	Dimensions (mm) / Abmessungen				CVD Coating / CVD Beschicht.				PVD Coating / PVD Beschicht.				Cermet / Cermet	Carbide uncoat. / unbe. Hartmetall											
		I.C	L	S	d	YBC301	YBC302	YBC401	YBM251	YBM253	YBM351	YBD152	YBD252		YBG102	YBG202	YBG205	YBG302	YBG152	YBG252	YNG151	YNG151C	YC30S	YD101	YD201	
	ROHX1203	12	8.5	3	4																					
	ROHX1604	16	11.3	4	5																					
	ROHX2005	20	14.1	5	5																					

Recommended Cutting data - Schnittdaten

Workpiece material / Werkstückstoff	Hardness HB / Härte	Grade / Sorte	Cutting data / Schnittdaten	Diameter / Durchmesser Ø D		
				Ø12	Ø16	Ø20
P carbon steel / leg. Kohlenstoff-stahl Alloy steel / Leg. Stahl Hardened steel / gehärteter Stahl	HB≤180	YBG202 YBG252	V(m/min)	100~200	100~200	100~200
			fz(mm/z)	0.15~0.25	0.2~0.3	0.2~0.3
			apmax(mm)	0.8	1	1.25
	HB180~280		V(m/min)	80~180	80~180	80~180
			fz(mm/z)	0.15~0.25	0.2~0.3	0.2~0.3
			apmax(mm)	0.8	1	1.25
	HRC55~65		V(m/min)	60~100	60~100	60~100
			fz(mm/z)	0.15~0.25	0.2~0.3	0.2~0.3
			apmax(mm)	0.4	0.5	0.6
M Stainless steel / Rostfreier Stahl	HB≤270	V(m/min)	70~150	70~150	70~150	
		fz(mm/z)	0.1~0.2	0.1~0.25	0.1~0.25	
		apmax(mm)	0.6	0.8	1	
		aemax(mm)	0.6	0.8	1	
K Cast iron / Gusseisen	HB180-250	V(m/min)	160~300	160~300	160~300	
		fz(mm/z)	0.2~0.3	0.25~0.35	0.25~0.35	
		apmax(mm)	1	1.5	1.8	
		aemax(mm)	1	1.5	1.8	

● Ex Stock / ab Lager ○ On demand / auf Anfrage



Profile milling tools · Profilfräser

BMR03 P M K

A (Ø30-Ø40)



B (Ø16-Ø25)



Straight shank
Zylinder Schaft

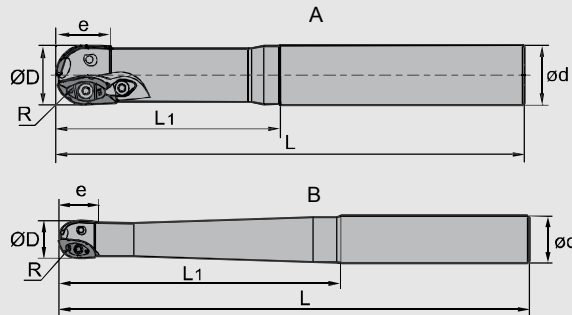

Specification of tools · Werkzeug Beschreibung

Type Typ	Stock Lager	Dimensions (mm) Abmessungen							No. of teeth Zähne	Weight Gewicht (kg)	Type Typ	Clamp Pratze
		R	Ø D	Ø d	L	L ₁	e					
BMR03												
-016-G20-S	●	8	16	20	150	70	16	2	0.3	B	WD-208	
-016-G20-M	●	8	16	20	180	80	16	2	0.4	B		
-020-G25-S	●	10	20	25	180	80	20	2	0.5	B		
-020-G25-M	●	10	20	25	200	100	20	2	0.6	B		
-020-G25-L	●	10	20	25	250	150	20	2	0.7	B		
-020-G25-XL	○	10	20	25	300	110	20	2	1.0	B		
-025-G25-S	●	12.5	25	25	180	80	25	2	0.6	B		
-025-G25-M	●	12.5	25	25	200	100	25	2	0.7	B		
-025-G25-L	○	12.5	25	25	250	110	25	2	0.8	B		
-025-G25-XL	○	12.5	25	25	300	120	25	2	1.0	B		
-030-G32-S	○	15	30	32	200	120	30	2	1.0	A	WD-208	
-030-G32-M	●	15	30	32	250	150	30	2	1.3	A		
-030-G32-L	○	15	30	32	300	200	30	2	1.6	A		
-030-G32-XL	○	15	30	32	350	200	30	2	1.9	A		
-032-G32-S	●	16	32	32	200	120	32	2	1.1	A		
-032-G32-M	●	16	32	32	250	150	32	2	1.4	A		
-032-G32-L	●	16	32	32	300	200	32	2	1.6	A	WD-208	
-032-G32-XL	○	16	32	32	350	200	32	2	2.0	A		
-040-G40-S	○	20	40	40	200	120	40	2	1.6	A		CBH5R1
-040-G40-M	○	20	40	40	250	150	40	2	2.0	A		
-040-G40-L	●	20	40	40	300	200	40	2	2.5	A		
-040-G40-XL	○	20	40	40	350	200	40	2	3.0	A		

● Ex Stock / ab Lager ○ On demand / auf Anfrage

Applicable tool B11-B18
Werkzeug

Tools code key B26-B27
Werkzeug ISO

Grade selection guide B19-B23
Sortenauswahl

Technical data B215-B220
Technische Daten

B

Milling Tools
Fräser



Profile milling tools · Profilfräser

BMR03 P M K

A (Ø30-Ø50)



B (Ø16-Ø25)

Weldon shank
Weldon Schaft

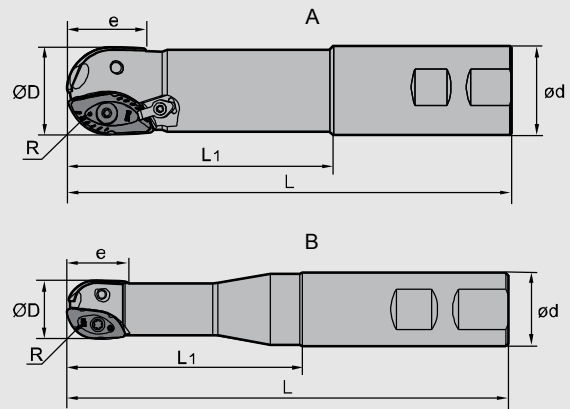

Specification of tools · Werkzeug Beschreibung

	Type Typ	Stock Lager	Dimensions (mm) Abmessungen						No. of teeth Zähne	Weight Gewicht (kg)	Type Typ	Clamp Pratze
			R	Ø D	ø d	L	L ₁	e				
BMR03	-016-XP20-M	●	8	16	20	111	60	16	2	0.2	B	WD-208
	-020-XP25-M	●	10	20	25	127	70	20	2	0.3	B	
	-020-XP25-L	●	10	20	25	150	80	20	2	0.4	B	
	-025-XP25-M	●	12.5	25	25	137	80	25	2	0.4	B	
	-025-XP25-L	●	12.5	25	25	200	100	25	2	0.6	B	
	-030-XP32-M	●	15	30	32	161	100	30	2	0.8	A	
	-030-XP32-L	●	15	30	32	250	150	30	2	1.3	A	
	-032-XP32-M	●	16	32	32	161	100	32	2	0.8	A	
	-032-XP32-L	○	16	32	32	250	120	32	2	1.3	A	
	-040-XP40-M	○	20	40	40	175	100	40	2	1.3	A	
	-040-XP40-L	●	20	40	40	250	120	40	2	2.0	A	
	-050-XP50-M	○	25	50	50	200	100	50	2	2.5	A	
-050-XP50-L	○	25	50	50	250	150	50	2	3.1	A	CBH5R1	

● Ex Stock / ab Lager ○ On demand / auf Anfrage



Profile milling tools · Profilfräser

BMR03 P M K

A (Ø30-Ø50)



B (Ø20-Ø25)

Morse taper shank
Morsekegel Schaft

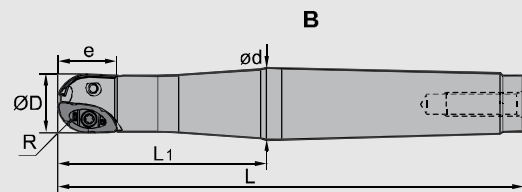
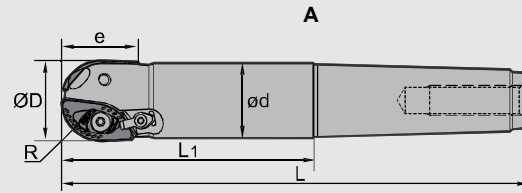

Specification of tools · Werkzeug Beschreibung

Type Typ	Stock Lager	Dimensions (mm) Abmessungen						No. of teeth Zähne	Weight Gewicht (kg)	type typ	Clamp Pratze	
		R	Ø D	ø d	L	L1	e					
BMR03	-020-MT3-M	○	10	20	18.7	156	70	20	2	0.4	B	
	-020-MT3-L	○	10	20	18.7	186	100	20	2	0.4	B	
	-025-MT3-M	○	12.5	25	23.5	156	70	25	2	0.4	B	
	-025-MT3-L	○	12.5	25	23.5	186	100	25	2	0.4	B	
	-030-MT4-M	○	15	30	28.2	189	70	30	2	0.8	A	WD-208
	-030-MT4-L	○	15	30	28.2	229	120	30	2	1.0	A	
	-032-MT4-M	○	16	32	29.2	179	70	32	2	0.9	A	
	-032-MT4-L	●	16	32	29.2	209	100	32	2	0.9	A	
	-040-MT4-M	○	20	40	36.9	199	100	40	2	1.0	A	CBH5R1
	-040-MT5-L	○	20	40	36.9	226	90	40	2	1.8	A	
	-040-MT5-XL	○	20	40	36.9	256	120	40	2	2.0	A	
	-050-MT5-M	●	25	50	46.8	236	100	50	2	2.2	A	
	-050-MT5-L	○	25	50	46.8	286	150	50	2	2.9	A	

Applicable tool
Werkzeug

B11-B18

Tools code key
Werkzeug ISO

B26-B27

Grade selection guide
Sortenauswahl

B19-B23

Technical data
Technische Daten

B215-B220

Profile milling tools · Profilfräser



BMR03 P M K

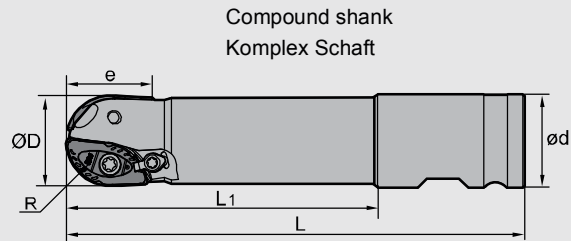

Specification of tools · Werkzeug Beschreibung

Type Typ	Stock Lager	Dimensions (mm) Abmessungen							No. of teeth Zähne	Weight Gewicht (kg)	Clamp Pratze
		R	Ø D	ø d	L	L ₁	e				
BMR03	-040-XPX-M	○	20	40	50.8	250	170	40	2	1.3	CBH5R1
	-040-XPX-L	○	20	40	50.8	300	220	40	2	3.1	
	-040-XPX-XL	○	20	40	50.8	350	270	40	2	3.5	
	-050-XPX-M	○	25	50	50.8	250	170	50	2	3.1	
	-050-XPX-L	○	25	50	50.8	300	200	50	2	3.8	
	-050-XPX-XL	○	25	50	50.8	350	270	50	2	4.4	

Spare parts · Ersatzteile

Diameter Durchmesser Ø D	Clamp Pratze	Screw Schraube	Wrench Schlüssel	
Φ16	--	I60M2.5×6.5	--	WT07P
Φ20	--	I60M3.5×08TT	--	WT10IP
Φ25	--	I60M4×10	--	WT15S
Φ30	WD-208	I60M5×13	WT20IT	--
Φ32	WD-208	I60M5×13	WT25IT	--
Φ40	CBH5R1	I43M6×16	WT25IT	--
Φ50	CBH5R1	I43M8×21	WT25IT	--
		I43M6×16	WT30IT	--



● Ex Stock / ab Lager ○ On demand / auf Anfrage

Milling - Fräsen

Indexable Milling Tools - Wendepplattenfräser

■ Applicable inserts · Wendeschneidplatten

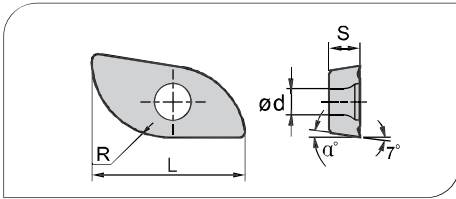

- Ideal Machining Condition / Gute Bearbeitungsbedingungen
- Normal Machining Condition / Normale Bearbeitungsbedingungen
- Unfavorable Machining Condition / Ungünstige Bearbeitungsbedingungen

Workpiece Material / Werkstoffe	P	M	K	N	S	YBC301	YBC302	YBC401	YBM251	YBM253	YBM351	YBD152	YBD252	YBG102	YBG202	YBG205	YBG302	YBG152	YBG252	YNG151	YNG151C	YC30S	YD101	YD201	
P Steel / Stahl	●	●	●	●	●	●	●	●	●	●	●	●	●	●	●	●	●	●	●	●	●	●	●	●	●
M Stainless Steel / Rostfreier Stahl	●	●	●	●	●	●	●	●	●	●	●	●	●	●	●	●	●	●	●	●	●	●	●	●	●
K Cast iron / Gusseisen	●	●	●	●	●	●	●	●	●	●	●	●	●	●	●	●	●	●	●	●	●	●	●	●	●
N Non-ferrous material / Ne Metalle	●	●	●	●	●	●	●	●	●	●	●	●	●	●	●	●	●	●	●	●	●	●	●	●	●
S Heat-resistant steel / Warmfester Stahl	●	●	●	●	●	●	●	●	●	●	●	●	●	●	●	●	●	●	●	●	●	●	●	●	●

Insert WSP	Type Typ	Dimensions (mm) / Abmessungen						CVD Coating / CVD Beschicht.						PVD Coating / PVD Beschicht.				Cermet / Cermet	Carbide uncoat. / unbe. Hartmetall							
		R	d	s	α°	L	Applicable tools / Entsprechendes Werkzeug	YBC301	YBC302	YBC401	YBM251	YBM253	YBM351	YBD152	YBD252	YBG102	YBG202		YBG205	YBG302	YBG152	YBG252	YNG151	YNG151C	YC30S	YD101
	XPHT16R0803-GM	8	3.1	3.18	9	16	Φ16											●								
	XPHT20R10T3-GM	10	4.0	3.97	9	20	Φ20											●								
	XPHT25R1204-GM	12.5	4.7	4.76	9	25	Φ25											●								
	XPHT30R1506-GM	15	5.8	6.35	11	30	Φ30											●								
	XPHT32R1606-GM	16	5.8	6.35	9	32	Φ32											●								
	XPHT40R2007-GM	20	6.8	7.94	9	40	Φ40											●								
	XPHT50R2507-GM	25	9.2	7.94	9	50	Φ50											●								

B

Milling Tools / Fräser



BMR03



Ball nose end mills - Serie - Kugelschaftfräser



- The unique chipbreaker design and big rake angle can effectively control the curling and flow direction of chippings and reduce the cutting force, improve workpiece surface quality and tool life.
 - The insert after precisely grinding periphery and locating surface can sufficiently ensure the shape accuracy of cutting edge and the precision of location and installation, improve the reliability of installation and the workpiece precision after machining.
 - The concave structure design of flank can effectively enhance the strength of cutting edge, and prevent the scraping between the clearance face and workpiece surface. Therefore it improves the workpiece surface quality and prolongs the life of insert.
 - The design of cutting edge over center and a big negative rake angle make it possible to cut vertically, thus the capability of anti-breakage is enhanced.
 - The rough ball nose milling cutters with big diameter adopt the top and hole clamping style, insert clamping becomes more firm and stable. The machining also is high efficiency even at the poor condition such as long overhang and large vibration etc.
 - The adapter types include straight shank, Weldon shank, Morse taper shank and compound shank.
-
- Das einzigartige Spanbrecherdesign mit großem Spanwinkel, kontrolliert Spanbildung und Spanabfuhr, reduziert die Schnittkräfte und erhöht die Werkzeuglebensdauer.
 - Die umfangsgeschliffene Schneidplatte und die Präzision des Plattensitzes sind ein Garant für die Erzielung einer hohen Werkstückqualität.
 - Die konkave Schneidengeometrie erhöht die Schneidkantenstabilität und schützt die Schneide vor Ausbrüchen.
 - Die Ausführung der Zentrumsschneide und ein großer negativer Spanwinkel ermöglicht eine vertikale Bearbeitung (Zustellung) und stabilisiert das Werkzeug.
 - Der Schrumpfradiusfräser für größere Durchmesser ist neben der Schrauben- mit einer zusätzlichen Prattenklemmung versehen. Dadurch wird die Schneidplattenklemmung deutlich erhöht. Dies ermöglicht eine effizientere Bearbeitung auch unter ungünstigen Bedingungen, wie bei langer Auskragung oder Vibrationen.
 - Durch verschiedene Schaftausführungen kann das Werkzeugsystem auf unterschiedlichen Maschinen eingesetzt werden.

Slot shape after machining
Nut nach der Bearbeitung

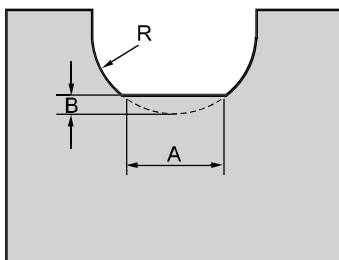

R	A	B
08	1.7	0.09
10	2.2	0.12
12.5	3.0	0.18
15	3.9	0.20
16	3.5	0.22
20	3.6	0.24
25	3.8	0.26

Diameter range
Durchmesser Bereich Ø16

Recommended Cutting data · Schnittdaten

Operations Anwendung						
Workpiece material Werkstückstoff	Cutting data Schnittdaten	Machining of slot Nutenfräsen	Side milling (slight) Schulterfräsen		Side milling (deep) Schulterfräsen	Grade Sorte
Medium carbon steel Kohlenstoffstahl Hardness Härte 150~250HB	V(m/min)	150~220	150~220	150~220	150~220	YBG302
	Fz(mm/z)	0.1~0.4	0.1~0.4	0.1~0.4	0.1~0.4	
	a _p (mm)	4	4	8	16	
	a _e (mm)	--	3	4	1.5	
Alloy steel Leg. Stahl Hardness Härte 150~280HB	V(m/min)	100~150	100~150	100~150	100~150	
	Fz(mm/z)	0.1~0.4	0.1~0.4	0.1~0.4	0.1~0.4	
	a _p (mm)	4	4	8	16	
	a _e (mm)	--	3	4	1.5	
Die steel Gesenkstahl Hardness Härte 150~255HB	V(m/min)	80~120	80~120	80~120	80~120	
	Fz(mm/z)	0.1~0.3	0.1~0.3	0.1~0.3	0.1~0.3	
	a _p (mm)	4	4	8	16	
	a _e (mm)	--	3	4	1.5	
Hardened steel gehärteter Stahl Hardness Härte 40~50HRC	V(m/min)	80~100	80~100	80~100	--	
	Fz(mm/z)	0.08~0.15	0.08~0.15	0.08~0.15	--	
	a _p (mm)	4	4	8	--	
	a _e (mm)	--	2	3	--	
Grey Cast iron Grauguss Hardness Härte 160~260HB	V(m/min)	250~300	250~300	250~300	250~300	
	Fz(mm/z)	0.08~0.15	0.08~0.15	0.08~0.15	0.08~0.15	
	a _p (mm)	4	4	8	16	
	a _e (mm)	--	3	4	1.5	
Nodular Cast iron Kugelgrafitguss Hardness Härte 170~300HB	V(m/min)	200~250	200~250	200~250	200~250	
	Fz(mm/z)	0.08~0.15	0.08~0.15	0.08~0.15	0.08~0.15	
	a _p (mm)	4	4	8	16	
	a _e (mm)	--	3	4	1.5	

Milling · Fräsen

Indexable Milling Tools · Wendeplattenfräser

Diameter range Ø20

Durchmesser Bereich Ø20

■ Recommended Cutting data · Schnittdaten

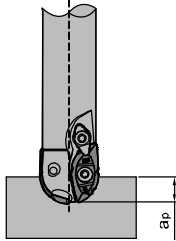
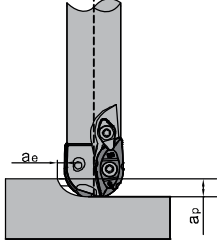
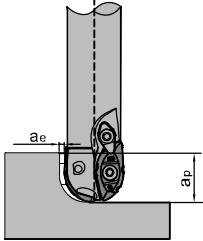
Operations Anwendung						
Workpiece material Werkstückstoff	Cutting data Schnittdaten	Machining of slot Nutenfräsen	Side milling (slight) Schulterfräsen		Side milling (deep) Schulterfräsen	Grade Sorte
Medium carbon steel Kohlenstoffstahl Hardness Härte 150~250HB	V(m/min)	150~220	150~220	150~220	150~220	YBG302
	Fz(mm/z)	0.1~0.4	0.1~0.4	0.1~0.4	0.1~0.4	
	a _p (mm)	5	5	10	20	
	a _e (mm)	--	4	5	2	
Alloy steel Leg. Stahl Hardness Härte 150~280HB	V(m/min)	100~150	100~150	100~150	100~150	
	Fz(mm/z)	0.1~0.4	0.1~0.4	0.1~0.4	0.1~0.4	
	a _p (mm)	5	5	10	20	
	a _e (mm)	--	4	5	2	
Die steel Gesenkstahl Hardness Härte 150~255HB	V(m/min)	80~120	80~120	80~120	80~120	
	Fz(mm/z)	0.1~0.3	0.1~0.3	0.1~0.3	0.1~0.3	
	a _p (mm)	5	5	10	20	
	a _e (mm)	--	4	5	2	
Hardened steel gehärteter Stahl Hardness Härte 40~50HRC	V(m/min)	80~100	80~100	80~100	--	
	Fz(mm/z)	0.08~0.15	0.08~0.15	0.08~0.15	--	
	a _p (mm)	5	5	10	--	
	a _e (mm)	--	4	5	--	
Grey Cast iron Grauguss Hardness Härte 160~260HB	V(m/min)	250~300	250~300	250~300	250~300	
	Fz(mm/z)	0.08~0.15	0.08~0.15	0.08~0.15	0.08~0.15	
	a _p (mm)	5	5	10	20	
	a _e (mm)	--	4	5	2	
Nodular Cast iron Kugelgraphitguss Hardness Härte 170~300HB	V(m/min)	200~250	200~250	200~250	200~250	
	Fz(mm/z)	0.08~0.15	0.08~0.15	0.08~0.15	0.08~0.15	
	a _p (mm)	5	5	10	20	
	a _e (mm)	--	4	5	2	

B

Milling Tools
Fräser

Diameter range
Durchmesser Bereich Ø25

Recommended Cutting data · Schnittdaten

Operations Anwendung						
Workpiece material Werkstückstoff	Cutting data Schnittdaten	Machining of slot Nutenfräsen	Side milling (slight) Schulterfräsen		Side milling (deep) Schulterfräsen	Grade Sorte
Medium carbon steel Kohlenstoffstahl Hardness Härte 150~250HB	V(m/min)	150~220	150~220	150~220	150~220	YBG302
	Fz(mm/z)	0.1~0.4	0.1~0.4	0.1~0.4	0.1~0.4	
	a _p (mm)	6	6	12.5	25	
	a _e (mm)	--	5	6.5	3	
Alloy steel Leg. Stahl Hardness Härte 150~280HB	V(m/min)	100~150	100~150	100~150	100~150	
	Fz(mm/z)	0.1~0.4	0.1~0.4	0.1~0.4	0.1~0.4	
	a _p (mm)	6	6	12.5	25	
	a _e (mm)	--	5	6.5	3	
Die steel Gesenkstahl Hardness Härte 150~255HB	V(m/min)	80~120	80~120	80~120	80~120	
	Fz(mm/z)	0.1~0.3	0.1~0.3	0.1~0.3	0.1~0.3	
	a _p (mm)	6	6	12.5	25	
	a _e (mm)	--	5	6.5	3	
Hardened steel gehärteter Stahl Hardness Härte 40~50HRC	V(m/min)	80~100	80~100	80~100	--	
	Fz(mm/z)	0.08~0.15	0.08~0.15	0.08~0.15	--	
	a _p (mm)	6	6	12.5	--	
	a _e (mm)	--	5	6.5	--	
Grey Cast iron Grauguss Hardness Härte 160~260HB	V(m/min)	250~300	250~300	250~300	250~300	
	Fz(mm/z)	0.08~0.15	0.08~0.15	0.08~0.15	0.08~0.15	
	a _p (mm)	6	6	12.5	25	
	a _e (mm)	--	5	6.5	3	
Nodular Cast iron Kugelgrafitguss Hardness Härte 170~300HB	V(m/min)	200~250	200~250	200~250	200~250	
	Fz(mm/z)	0.08~0.15	0.08~0.15	0.08~0.15	0.08~0.15	
	a _p (mm)	6	6	12.5	25	
	a _e (mm)	--	5	6.5	3	

Milling · Fräsen

Indexable Milling Tools · Wendeplattenfräser

Diameter range

Durchmesser Bereich Ø30 Ø32

Recommended Cutting data · Schnittdaten

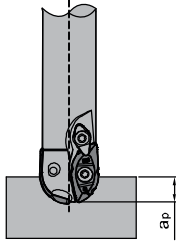
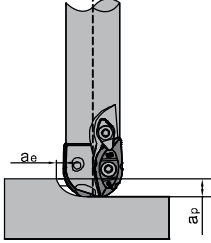
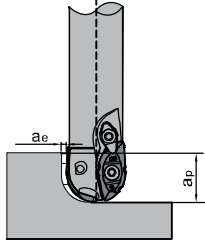
Operations Anwendung						
Workpiece material Werkstückstoff	Cutting data Schnittdaten	Machining of slot Nutenfräsen	Side milling (slight) Schulterfräsen		Side milling (deep) Schulterfräsen	Grade Sorte
Medium carbon steel Kohlenstoffstahl Hardness Härte 150~250HB	V(m/min)	150~220	150~220	150~220	150~220	YBG302
	Fz(mm/z)	0.1~0.4	0.1~0.4	0.1~0.4	0.1~0.4	
	a _p (mm)	10	10	16	28	
	a _e (mm)	--	6	9	6	
Alloy steel Leg. Stahl Hardness Härte 150~280HB	V(m/min)	100~150	100~150	100~150	100~150	
	Fz(mm/z)	0.1~0.4	0.1~0.4	0.1~0.4	0.1~0.4	
	a _p (mm)	10	10	16	28	
	a _e (mm)	--	6	9	6	
Die steel Gesenkstahl Hardness Härte 150~255HB	V(m/min)	80~120	80~120	80~120	80~120	
	Fz(mm/z)	0.1~0.3	0.1~0.3	0.1~0.3	0.1~0.3	
	a _p (mm)	10	10	16	28	
	a _e (mm)	--	6	9	6	
Hardened steel gehärteter Stahl Hardness Härte 40~50HRC	V(m/min)	80~100	80~100	80~100	--	
	Fz(mm/z)	0.08~0.15	0.08~0.15	0.08~0.15	--	
	a _p (mm)	10	10	16	--	
	a _e (mm)	--	6	9	--	
Grey Cast iron Grauguss Hardness Härte 160~260HB	V(m/min)	250~300	250~300	250~300	250~300	
	Fz(mm/z)	0.08~0.15	0.08~0.15	0.08~0.15	0.08~0.15	
	a _p (mm)	10	10	16	28	
	a _e (mm)	--	6	9	6	
Nodular Cast iron Kugelgrafitguss Hardness Härte 170~300HB	V(m/min)	200~250	200~250	200~250	200~250	
	Fz(mm/z)	0.08~0.15	0.08~0.15	0.08~0.15	0.08~0.15	
	a _p (mm)	10	10	16	28	
	a _e (mm)	--	6	9	6	

B

Milling Tools
Fräser

Diameter range

Durchmesser Bereich Ø40

Recommended Cutting data · Schnittdaten

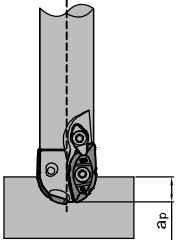
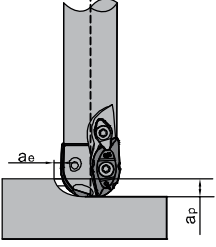
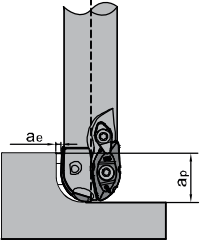
Operations Anwendung						
Workpiece material Werkstückstoff	Cutting data Schnittdaten	Machining of slot Nutenfräsen	Side milling (slight) Schulterfräsen		Side milling (deep) Schulterfräsen	Grade Sorte
Medium carbon steel Kohlenstoffstahl Hardness Härte 150~250HB	V(m/min)	150~220	150~220	150~220	150~220	YBG302
	Fz(mm/z)	0.1~0.4	0.1~0.4	0.1~0.4	0.1~0.4	
	a _p (mm)	12	10	20	35	
	a _e (mm)	--	8	12	8	
Alloy steel leg. Stahl Hardness Härte 150~280HB	V(m/min)	100~150	100~150	100~150	100~150	
	Fz(mm/z)	0.1~0.4	0.1~0.4	0.1~0.4	0.1~0.4	
	a _p (mm)	12	10	20	35	
	a _e (mm)	--	8	12	8	
Die steel Gesenkstahl Hardness Härte 150~255HB	V(m/min)	80~120	80~120	80~120	80~120	
	Fz(mm/z)	0.1~0.3	0.1~0.3	0.1~0.3	0.1~0.3	
	a _p (mm)	12	10	20	35	
	a _e (mm)	--	8	12	8	
Hardened steel gehärteter Stahl Hardness Härte 40~50HRC	V(m/min)	80~100	80~100	80~100	--	
	Fz(mm/z)	0.08~0.15	0.08~0.15	0.08~0.15	--	
	a _p (mm)	12	10	20	--	
	a _e (mm)	--	8	12	--	
Grey Cast iron Grauguss Hardness Härte 160~260HB	V(m/min)	250~300	250~300	250~300	250~300	
	Fz(mm/z)	0.08~0.15	0.08~0.15	0.08~0.15	0.08~0.15	
	a _p (mm)	12	10	20	35	
	a _e (mm)	--	8	12	8	
Nodular Cast iron Kugelgranitguss Hardness Härte 170~300HB	V(m/min)	200~250	200~250	200~250	200~250	
	Fz(mm/z)	0.08~0.15	0.08~0.15	0.08~0.15	0.08~0.15	
	a _p (mm)	12	10	20	35	
	a _e (mm)	--	8	12	8	

Milling · Fräsen

Indexable Milling Tools · Wendeplattenfräser

Diameter range
Durchmesser Bereich Ø50

Recommended Cutting data · Schnittdaten

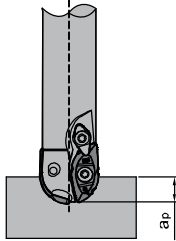
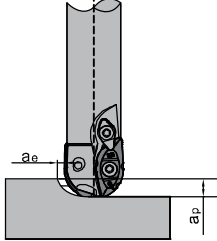
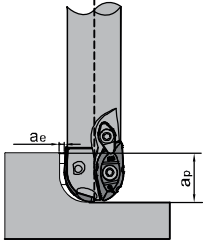
Operations Anwendung						
Workpiece material Werkstückstoff	Cutting data Schnittdaten	Machining of slot Nutenfräsen	Side milling (slight) Schulterfräsen		Side milling (deep) Schulterfräsen	Grade Sorte
Medium carbon steel Kohlenstoffstahl Hardness Härte 150~250HB	V(m/min)	150~220	150~220	150~220	150~220	YBG302
	Fz(mm/z)	0.1~0.4	0.1~0.4	0.1~0.4	0.1~0.4	
	a _p (mm)	15	10	25	40	
	a _e (mm)	--	10	15	10	
Alloy steel leg. Stahl Hardness Härte 150~280HB	V(m/min)	100~150	100~150	100~150	100~150	
	Fz(mm/z)	0.1~0.4	0.1~0.4	0.1~0.4	0.1~0.4	
	a _p (mm)	15	10	25	40	
	a _e (mm)	--	10	15	10	
Die steel Gesenkstahl Hardness Härte 150~255HB	V(m/min)	80~120	80~120	80~120	80~120	
	Fz(mm/z)	0.1~0.3	0.1~0.3	0.1~0.3	0.1~0.3	
	a _p (mm)	15	10	25	40	
	a _e (mm)	--	10	15	10	
Hardened steel gehärteter Stahl Hardness Härte 40~50HRC	V(m/min)	80~100	80~100	80~100	--	
	Fz(mm/z)	0.08~0.15	0.08~0.15	0.08~0.15	--	
	a _p (mm)	15	10	25	--	
	a _e (mm)	--	10	15	--	
Grey Cast iron Grauguss Hardness Härte 160~260HB	V(m/min)	250~300	250~300	250~300	250~300	
	Fz(mm/z)	0.08~0.15	0.08~0.15	0.08~0.15	0.08~0.15	
	a _p (mm)	15	10	25	40	
	a _e (mm)	--	10	15	10	
Nodular Cast iron Kugelgrafitguss Hardness Härte 170~300HB	V(m/min)	200~250	200~250	200~250	200~250	
	Fz(mm/z)	0.08~0.15	0.08~0.15	0.08~0.15	0.08~0.15	
	a _p (mm)	15	10	25	40	
	a _e (mm)	--	10	15	10	

B

Milling Tools
Fräser



Profile milling tools · Profilfräser

BMR04 P M K



Straight shank
Zylinderschaft

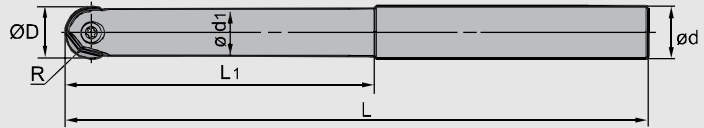

Specification of tools · Werkzeug Beschreibung

	Type Typ	Stock Lager	Dimensions (mm) Abmessungen						Weight Gewicht (kg)
			R	Ø D	ø d	ø d ₁	L ₁	L	
BMR04	-012-G12-M	●	6	12	12	11	35	125	0.1
	-012-G12-L	●	6	12	12	11	45	150	0.1
	-016-G16-M	●	8	16	16	14	40	150	0.2
	-016-G16-L	●	8	16	16	14	55	180	0.3
	-020-G20-M	●	10	20	20	18	65	180	0.4
	-020-G20-L	●	10	20	20	18	100	250	0.6
	-025-G25-M	●	12.5	25	25	23	70	200	0.7
	-025-G25-L	●	12.5	25	25	23	100	250	0.9
	-030-G32-M	●	15	30	32	27	80	250	1.2
	-030-G32-L	●	15	30	32	27	110	300	1.5
	-032-G32-M	●	16	32	32	29	80	250	1.4
	-032-G32-L	●	16	32	32	29	110	300	1.7

● Ex Stock / ab Lager ○ On demand / auf Anfrage

Applicable tool
Werkzeug **B11-B18**

Tools code key
Werkzeug ISO **B26-B27**

Grade selection guide
Sortenauswahl **B19-B23**

Technical data
Technische Daten **B215-B220**



Profile milling tools · Profilfräser

BMR04 P M K



Straight shank
Zylinderschaft

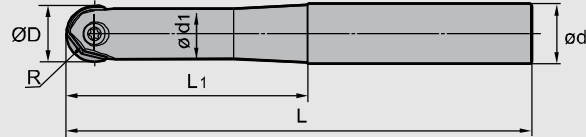





Specification of tools · Werkzeug Beschreibung

	Type Typ	Stock Lager	Dimensions (mm) Abmessungen						Weight Gewicht (kg)
			R	Ø D	ø d	ø d ₁	L ₁	L	
BMR04	-012-G16-M	●	6	12	16	11	50	125	0.2
	-012-G16-L	●	6	12	16	11	70	150	0.2
	-016-G20-M	●	8	16	20	14	60	150	0.3
	-016-G20-L	●	8	16	20	14	80	180	0.3
	-020-G25-M	●	10	20	25	18	75	180	0.6
	-020-G25-L	●	10	20	25	18	95	200	0.6
	-025-G32-M	●	12.5	25	32	23	90	200	1.0
	-025-G32-L	●	12.5	25	32	23	110	250	1.3
	-030-G40-M	●	15	30	40	27	110	250	2.0
	-030-G40-L	●	15	30	40	27	125	300	2.4
	-032-G40-M	●	16	32	40	29	110	250	2.0
	-032-G40-L	●	16	32	40	29	125	300	2.4

● Ex Stock / ab Lager ○ On demand / auf Anfrage

Spare parts · Ersatzteile

Diameter Durchmesser Ø D	Screw Schraube	Wrench Schlüssel	
			
Ø12	I90M4×09TT	WT15P	--
Ø16	I90M5×11TT	WT20P	--
Ø20	I90M5×13.5TT	WT20P	--
Ø25	I70M6×20TT	WT20P	--
Ø30	I70M8×25TT	--	WT30IT
Ø32	I70M8×25TT	--	WT30IT



Applicable inserts · Wendeschneidplatten

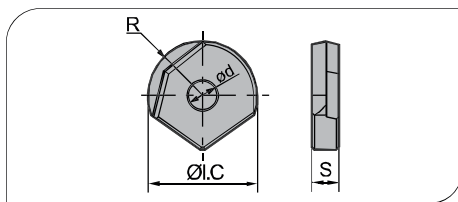

-  Ideal Machining Condition
Gute Bearbeitungsbedingungen
-  Normal Machining Condition
Normale Bearbeitungsbedingungen
-  Unfavorable Machining Condition
Ungünstige Bearbeitungsbedingungen

Workpiece Material Werkstoffe	P	M	K	N	S	YBC301	YBC302	YBC401	YBM251	YBM253	YBM351	YBD152	YBD252	YBG102	YBG202	YBG205	YBG302	YBG152	YBG252	YNG151	YNG151C	YC30S	YD101	YD201
P Steel Stahl	●	●	●	●	●	●	●	●	●	●	●	●	●	●	●	●	●	●	●	●	●	●	●	●
M Stainless Steel Rostfreier Stahl	●	●	●	●	●	●	●	●	●	●	●	●	●	●	●	●	●	●	●	●	●	●	●	●
K Cast iron Gusseisen	●	●	●	●	●	●	●	●	●	●	●	●	●	●	●	●	●	●	●	●	●	●	●	●
N Non-ferrous material Ne Metalle	●	●	●	●	●	●	●	●	●	●	●	●	●	●	●	●	●	●	●	●	●	●	●	●
S Heat-resistant steel Wärmebeständiger Stahl	●	●	●	●	●	●	●	●	●	●	●	●	●	●	●	●	●	●	●	●	●	●	●	●

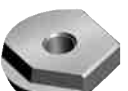
Insert WSP	Type Typ	Dimensions (mm) Abmessungen				Applicable insert Zugehörige WSP	CVD Coating CVD Beschicht.						PVD Coating PVD Beschicht.				Cermet Cermet	Carbide uncoat. unbe. Hartmetall							
		R	I.C	S	d		YBC301	YBC302	YBC401	YBM251	YBM253	YBM351	YBD152	YBD252	YBG102	YBG202		YBG205	YBG302	YBG152	YBG252	YNG151	YNG151C	YC30S	YD101
	ZOHX1203-GF	6	12	3	4	Φ12															●				
	ZOHX1604-GF	8	16	4	5	Φ16															●				
	ZOHX2005-GF	10	20	5	5	Φ20															●				
	ZOHX2506-GF	12.5	25	6	6	Φ25															○				
	ZOHX3007-GF	15	30	7	8	Φ30															●				
	ZOHX3207-GF	16	32	7	8	Φ32															●				
	ZOHX1203-GM	6	12	3	4	Φ12														●					
	ZOHX1604-GM	8	16	4	5	Φ16														●					
	ZOHX2005-GM	10	20	5	5	Φ20														●					
	ZOHX2506-GM	12.5	25	6	6	Φ25														○					
	ZOHX3007-GM	15	30	7	8	Φ30														●					
	ZOHX3207-GM	16	32	7	8	Φ32														●					

Applicable tool B11-B18
Werkzeug

Tools code key B26-B27
Werkzeug ISO

Grade selection guide B19-B23
Sortenauswahl

Technical data B215-B220
Technische Daten

BMR04

-GF

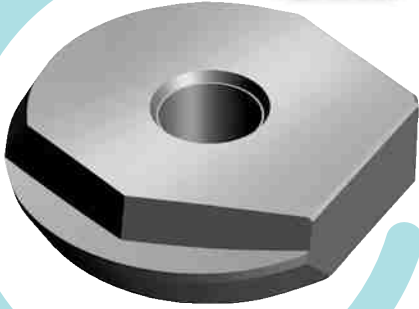

Positive rake angle and double clearance angle, the design of curved cutting edge take both sharpness and strength into consideration. The edge with high precision is applicable in the stable machining condition and the condition with high precision demand for workpiece profile.

Das spezielle Design aus positivem Spanwinkel und doppeltem Freiwinkel ermöglicht sowohl eine scharfe wie auch stabile Schneidkantenausführung. Die GF-Geometrie eignet sich besonders für Hochpräzisions- und Schlichtbearbeitung unter stabilen Maschinenbedingungen.

-GM

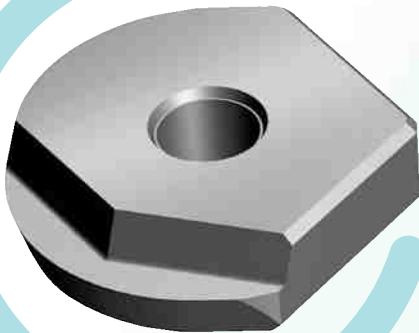

0° rake angle, only one clearance angle, high edge strength. Suitable for the machining condition requiring high cutting efficiency.

0° Grad Spanwinkel mit definiertem Freiwinkel ergeben eine sehr stabile Schneidkante. Für mittlere Bearbeitung mit hoher Effizienz.

The grade YBG 252 is a perfect combination of ultra fine grain carbide substrate and nano PVD-Coating.

Die Sorte YBG 252 ist die ideale Kombination von Ultra-Feinkorn-Hartmetallsubstrat und einer Nano-PVD-Beschichtung.

Calculation of cutting data for ball nose endmills (BMR02/04 series) Kalkulation der Schnittdaten für Kugelkopfräser (BMR02/04)

1. when tool axial line is vertical to the machined surface
Axiale Werkzeugachse zur vertikalen Fräsfläche:

$$N = \frac{1000 Vc}{\pi Dc} (r/min)$$

$$Dc = 2\sqrt{a_p(D - a_p)}$$

- N: revolution/min
Umdrehung/min
Vc: real cutting speed
effektive Schnittgeschwindigkeit
Dc: effective cutting diameter
effektive Ø
D: tool nominal diameter
nominale Ø
a_p: axial cutting depth
axiale Schnitttiefe

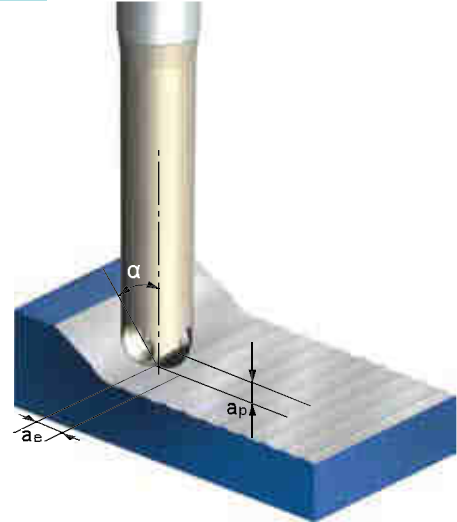

2. When there is a inclined angle between the tool axial line and the machined surface, the recommended cutting speed should be multiplied by a factor in the follow table to obtain the cutting speed used for programming

Unter Berücksichtigung des Neigungswinkels, (Werkzeugachse / bearbeitenden Oberfläche) erhalten Sie die empfohlene Schnittgeschwindigkeit durch in der Tabelle angegebene Multiplikator.

Diameter (mm) Durchmesser (mm) Ø		Ø12		Ø16		Ø20		Ø25		Ø30		Ø32	
depth of cut Schnitttiefe a _p (mm)		0.2	0.5	0.2	0.5	0.5	1	0.5	1	0.5	1.5	0.5	1.5
Inclined angle	15°	1.00	1.00	1.00	1.00	1.00	1.02	1.00	1.01	1.00	1.00	1.00	1.00
	30°	1.04	1.01	1.05	1.01	1.02	1.04	1.03	1.04	1.04	1.01	1.04	1.00
	45°	1.16	1.07	1.18	1.10	1.12	1.06	1.14	1.08	1.16	1.06	1.16	1.06
Neigungs- winkel α	60°	1.42	1.24	1.47	1.30	1.34	1.21	1.38	1.25	1.42	1.21	1.43	1.22
	75°	2.02	1.60	2.14	1.73	1.83	1.53	1.93	1.62	2.01	1.53	2.04	1.55
	90°	3.92	2.50	4.48	2.87	3.20	2.29	3.57	2.55	3.9	2.29	4.03	2.37

Milling · Fräsen

Indexable Milling Tools · Wendeplattenfräser

Recommended Cutting data · Schnittdaten

Workpiece material Werkstückstoff	Hardness Härte HB	Grade Sorte	Cutting data Schnittdaten	Diameter Durchmesser Ø D						
				Ø12	Ø16	Ø20	Ø25	Ø30	Ø32	
P carbon steel leg. Kohlenstoff- stahl	HB≤180	YBG252	V(m/min)	100~200	100~200	100~200	100~200	100~200	100~200	
			fz(mm/z)	0.15~0.25	0.2~0.3	0.2~0.3	0.25~0.35	0.25~0.35	0.25~0.35	
			a _{pmax} (mm)	0.8	1	1.25	1.5	2	2	
			a _{emax} (mm)	0.8	1	1.25	1.5	2	2	
	Alloy steel Leg. Stahl		HB180~280	V(m/min)	80~180	80~180	80~180	80~180	80~180	80~180
				fz(mm/z)	0.15~0.25	0.2~0.3	0.2~0.3	0.25~0.35	0.25~0.35	0.25~0.35
				a _{pmax} (mm)	0.8	1	1.25	1.5	2	2
				a _{emax} (mm)	0.8	1	1.25	1.5	2	2
	Hardened steel gehärteter Stahl		HRC55~65	V(m/min)	60~100	60~100	60~100	60~100	60~100	60~100
				fz(mm/z)	0.15~0.25	0.2~0.3	0.2~0.3	0.25~0.35	0.25~0.35	0.25~0.35
				a _{pmax} (mm)	0.4	0.5	0.6	0.8	1	1
				a _{emax} (mm)	0.4	0.5	0.6	0.8	1	1
M Stainless steel Rostfreier Stahl	HB≤270	V(m/min)	70~150	70~150	70~150	70~150	70~150	70~150		
		fz(mm/z)	0.1~0.2	0.1~0.25	0.1~0.25	0.2~0.3	0.2~0.3	0.2~0.3		
		a _{pmax} (mm)	0.6	0.8	1	1.25	1.5	1.5		
		a _{emax} (mm)	0.6	0.8	1	1.25	1.5	1.5		
K Cast iron Gusseisen	HB180-250	V(m/min)	160~300	160~300	160~300	160~300	160~300	160~300		
		fz(mm/z)	0.2~0.3	0.25~0.35	0.25~0.35	0.3~0.4	0.3~0.4	0.3~0.4		
		a _{pmax} (mm)	1	1.5	1.8	2	2.5	2.5		
		a _{emax} (mm)	1	1.5	1.8	2	2.5	2.5		

● Ex Stock / ab Lager ○ On demand / auf Anfrage

Case study for BMR04 Bearbeitungsbeispiel für BMR04



- Tool / Werkzeug: BMR04-020-G25-M
- Insert / WSP: ZOHX2005-GM/YBG252

Workpiece material: 42CrMo (HRC35)
Werkstückstoff:

Cooling system: dry cutting
Kühlsystem: trocken

Machine: vertical machining center
Maschine: vertikales Maschinen-Center

Cutting data
Schnittdaten:

$V_c=150\text{m/min}$

$a_p=0.1\text{mm}$

$f_z=0.2\text{mm/Z}$

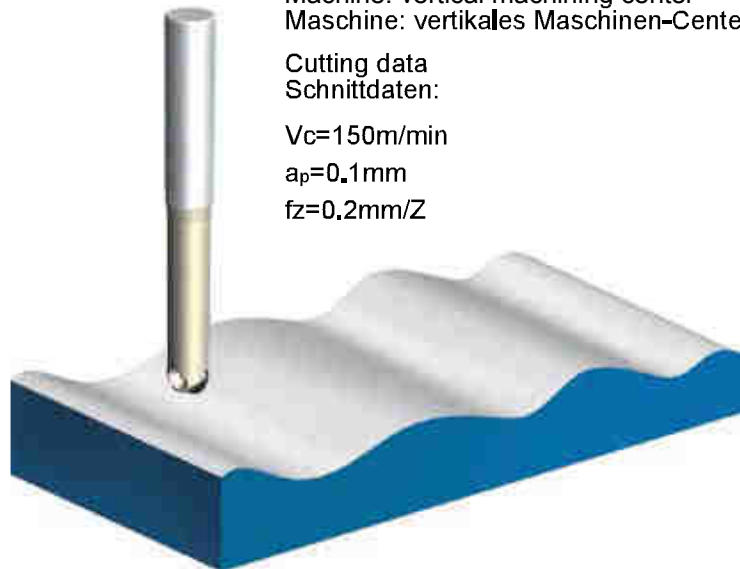

● Abrasion comparison of inserts after milling curved face Vergleich des Freiflächenverschleiß nach dem Fräsen einer Freiformfläche

ZCC-CT

Competitor A
Wettbewerber A

60 minutes later
Nach 60 Minuten



Flank abrasion 0.08
Freiflächenverschleiß 0.08

Flank abrasion 0.10
Freiflächenverschleiß 0.10

120 minutes later
Nach 120 Minuten



Flank abrasion 0.12
Freiflächenverschleiß 0.12

Flank abrasion 0.16
Freiflächenverschleiß 0.16

Applicable tool
Werkzeug

[B11-B18](#)

Tools code key
Werkzeug ISO

[B26-B27](#)

Grade selection guide
Sortenauswahl

[B19-B23](#)

Technical data
Technische Daten

[B215-B220](#)

Milling - Fräsen

Indexable Milling Tools - Wendeplattenfräser

Side and face milling tools - Scheiben- und Planfräser code key

Milling tool type Fräserotyp	
FM	Face milling Planfräsen
EM	Square shoulder milling Eckfräsen
HM	Helical end milling Spiralfräsen
SM	Side and face milling Eck- und Planfräsen
BM	Profile milling Profilfräsen
CM	Chamfer milling Fasfräsen
XM	Special milling Spezialfräsen

Approach angle Anstellwinkel		
P	90°	
E	75°	
D	60°	
A	45°	
R		

Sequence number of series
Serien Nummer

Cutting diameter ØD (mm)
Fräserdurchmesser

Cutting width of milling tools
Schnittbreite

Coupling structure and demension Aufnahmetyp			
A	A type / A Typ	D	D type / D Typ
B	B type / B Typ	K	Mounting by keyway Mit Passfeder
C	C type / C Typ		

SM P 03 - 160 × 16 - K40

- M P 12 - 12 L

Insert WSP	
C	Diamond with 80° Raute mit 80°
D	Diamond with 55° Raute mit 55°
R	Round Rund
S	Square Viereckig
T	Regular triangle dreieckig
V	Diamond with 35° Raute mit 35°
M	Diamond with 86° Raute mit 86°

Insert clearance angle Freiwinkel	
N	0°
B	5°
C	7°
P	11°
D	15°
E	20°

Diameter of IC Durchmesse Innenkreis	Length of cutting edge Schneidkantenlänge					
	Insert · WSP					
	C	D	R	S	T	V
5.556	—	—	—	—	09	—
6.350	06	07	—	—	11	—
9.525	09	11	09	09	16	16
12.700	12	15	12	12	22	22
15.875	16	19	15	15	27	—
19.050	19	—	19	19	33	—
25.400	25	—	25	25	44	—

Cutting direction
Schnitttrichtung
(R: right L: left)
(R: rechts L: links)

Number of teeth
Zähnezahl

Milling Tools
Fräser

Side and face milling tools · Scheibenfräser



SMP01 P M K

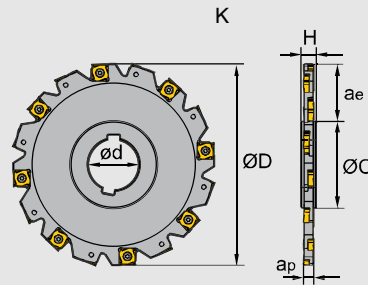

Specification of tools · Werkzeug Beschreibung

Type Typ	Stock Lager	Dimensions (mm) Abmessungen							Inserts WSP	No. of teeth Zähne	Coupling Aufnahme	Weight Gewicht (kg)		
		Ø D	ø d	ø c	H	ap	ae _{max}							
SMP01 SMP01 Mounting by keyway	-100×4-K27-SN12-10	○	100	27	45	12	4	25	XSEQ1202	10	K	0.2		
	-125×4-K40-SN12-12	○	125	40	56	12	4	32		12	K	0.3		
	-160×4-K40-SN12-16	●	160	40	67	12	4	44		16	K	0.5		
Mit Passfeder	-100×5-K27-SN12-10	●	100	27	45	12	5	25	XSEQ1203	10	K	0.2		
	-125×5-K40-SN12-12	○	125	40	56	12	5	32		12	K	0.3		
	-160×5-K40-SN12-16	●	160	40	67	12	5	44		16	K	0.6		
	-100×6-K27-SN12-10	○	100	27	45	12	6	25		XSEQ12T3	10	K	0.3	
	-125×6-K40-SN12-12	●	125	40	56	12	6	32			12	K	0.4	
	-160×6-K40-SN12-16	●	160	40	67	12	6	44			16	K	0.7	
	-200×6-K50-SN12-18	●	200	50	71	12	6	62			18	K	1.1	
	-250×6-K50-SN12-24	●	250	50	71	12	6	87			24	K	1.7	
	-100×7-K27-SN12-10	●	100	27	45	12	7	25			XSEQ1204	10	K	0.3
	-125×7-K40-SN12-12	●	125	40	56	12	7	32				12	K	0.4
	-160×7-K40-SN12-16	●	160	40	67	12	7	44				16	K	0.8
	-200×7-K50-SN12-18	●	200	50	71	12	7	62				18	K	1.2
-250×7-K50-SN12-24	○	250	50	71	12	7	87	24	K		1.9			
-100×8-K27-SN12-10	●	100	27	45	12	8	25	XSEQ12T4	10		K	0.3		
-125×8-K40-SN12-12	●	125	40	56	12	8	32		12		K	0.5		
-160×8-K40-SN12-16	○	160	40	67	12	8	44		16	K	0.9			
-200×8-K50-SN12-18	●	200	50	71	12	8	62		18	K	1.4			
-250×8-K50-SN12-24	●	250	50	71	12	8	87		24	K	2.2			

● Ex Stock / ab Lager ○ On demand / auf Anfrage

Applicable tool B11-B18
Werkzeug

Tools code key B26-B27
Werkzeug ISO

Grade selection guide B19-B23
Sortenauswahl

Technical data B215-B220
Technische Daten

Side and face milling tools · Scheibenfräser



SMP01 **P** **M** **K**

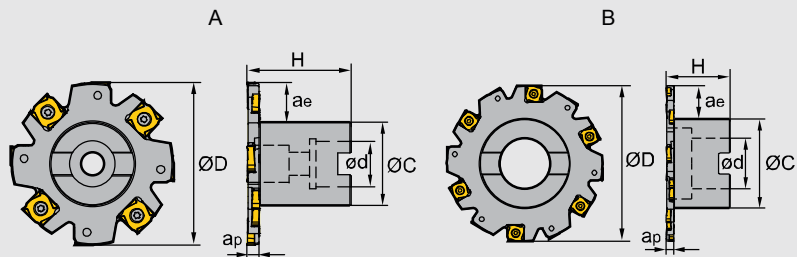

Specification of tools · Werkzeug Beschreibung

Type Typ	Stock Lager		Dimensions (mm) Abmessungen							Inserts WSP	No. of teeth Zähne	Coupling Aufnahme	Weight Gewicht (kg)
	R	L	Ø D	Ø d	Ø c	H	ap	aemax					
SMP01 Arbor mounting	-063×4-A22-SN12-06	●	○	63	22	32	40	4	14	XSEQ1202	6	A	0.2
	-080×4-A22-SN12-08	●	○	80	22	40	40	4	18		8	A	0.4
	-100×4-A27-SN12-10	●	○	100	27	48	50	4	23		10	A	0.6
Arbor Aufnahme	-063×5-A22-SN12-06	○	○	63	22	32	40	5	14	XSEQ1203	6	A	0.2
	-080×5-A22-SN12-08	●	○	80	22	40	40	5	18		8	A	0.4
	-100×5-A27-SN12-10	●	○	100	27	48	50	5	23		10	A	0.7
	-063×6-A22-SN12-06	○	○	63	22	32	40	6	14	XSEQ12T3	6	A	0.2
	-080×6-A22-SN12-08	●	○	80	22	40	40	6	18		8	A	0.5
	-100×6-A27-SN12-10	●	○	100	27	48	50	6	23		10	A	0.7
	-125×6-B40-SN12-12	○	○	125	40	70	50	6	30		12	B	1.0
	-160×6-B40-SN12-16	○	○	160	40	70	60	6	41		16	B	1.3
	-063×7-A22-SN12-06	○	○	63	22	32	40	7	14		XSEQ1204	6	A
-080×7-A22-SN12-08	○	○	80	22	40	40	7	18	8	A		0.5	
-100×7-A27-SN12-10	○	○	100	27	48	50	7	23	10	A		0.7	
	-125×7-B40-SN12-12	○	○	125	40	70	50	7	30		12	B	1.1
	-160×7-B40-SN12-16	○	○	160	40	70	60	7	41		16	B	1.4
	-063×8-A22-SN12-06	○	○	63	22	32	40	8	14		XSEQ12T4	6	A
-080×8-A22-SN12-08	●	○	80	22	40	40	8	18	8	A		0.5	
-100×8-A27-SN12-10	●	○	100	27	48	50	8	23	10	A		0.8	
	-125×8-B40-SN12-12	●	○	125	40	70	50	8	30		12	B	1.1
	-160×8-B40-SN12-16	○	○	160	40	70	60	8	41		16	B	1.5

● Ex Stock / ab Lager ○ On demand / auf Anfrage

Milling · Fräsen

Indexable Milling Tools · Wendepplattenfräser

Side and face milling tools · Scheibenfräser



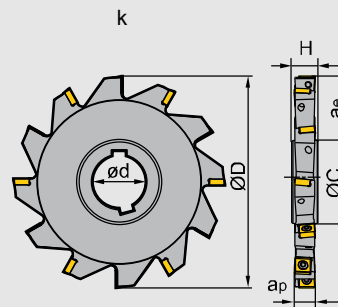

SMP03 P M K



■ Specification of tools ·

Type Typ	Stock Lager	Dimensions (mm) Abmessungen							Inserts WSP	No. of teeth Zähne	Coupling Aufnahme	Weight Gewicht (kg)	
		ØD	øc	ød	ae _{max}	ap	H						
SMP03 Arbor mounting	○	-080×8-K27-MP06-10	80	44.0	27	17.6	8	12	MPHT060304-DM	10	K	0.2	
	●	-100×8-K32-MP06-14	100	49.0	32	25.1	8	12		14	K	0.3	
Arbor Aufnahme	●	-100×10-K32-MP06-14	100	49.0	32	25.1	10	14		MPHT080305-DM	14	K	0.4
	○	-125×10-K40-MP06-16	125	57.0	40	33.6	10	14			16	K	0.6
	○	-125×12-K40-MP08-12	125	58.3	40	32.6	12	16		MPHT120408-DM	12	K	0.7
	●	-160×12-K40-MP08-14	160	64.3	40	31.5	12	16			14	K	1.3
	○	-160×16-K40-MP12-12	160	64.6	40	47.6	16	20		MPHT120408-DM	12	K	1.6
	○	-160×18-K40-MP12-12	160	65.3	40	47.3	18	24			12	K	1.9
	○	-160×20-K40-MP12-12	160	65.3	40	47.3	20	26			12	K	2.1
	○	-200×16-K50-MP12-14	200	74.6	50	62.6	16	20			14	K	2.5
	○	-200×18-K50-MP12-14	200	75.3	50	62.3	18	24		14	K	2.9	
	●	-200×20-K50-MP12-14	200	75.3	50	62.3	20	26		14	K	3.3	

■ Spare parts · Ersatzteile

Diameter Durchmesser Ø D	Insert WSP	Screw Schraube	Wrench Schlüssel	
				
Ø80-Ø125	MP06	I60M2.5x6.5	WT07IP	--
Ø125-Ø160	MP08	I60M3x7	WT09IP	--
Ø160-Ø200	MP12	I60M5x13	--	WT20IS



● Ex Stock / ab Lager ○ On demand / auf Anfrage

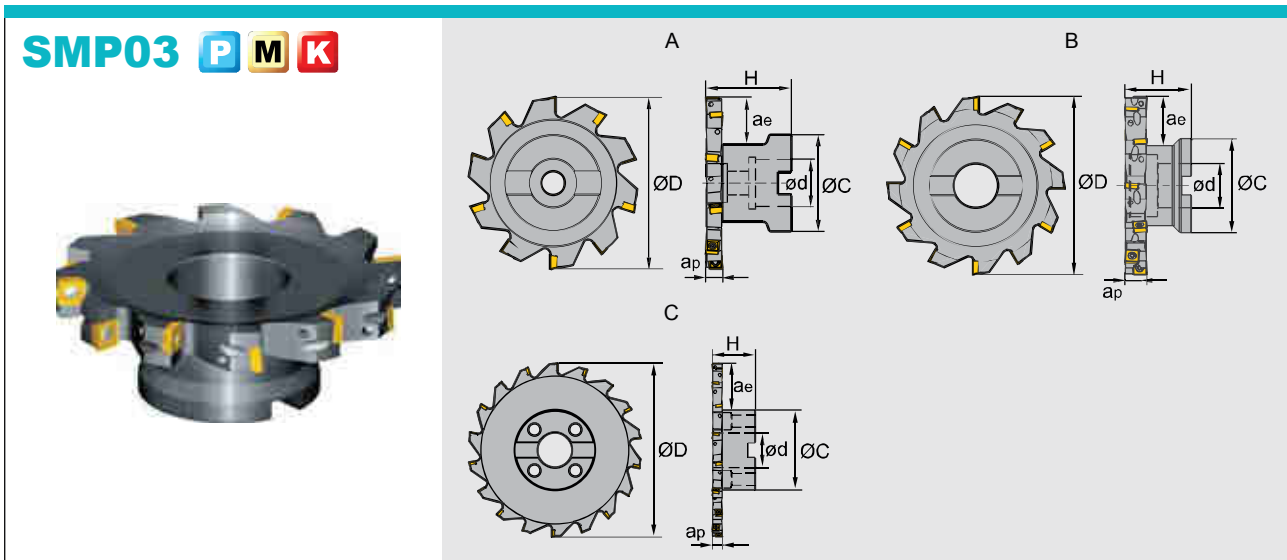

Side and face milling tools · Scheibenfräser



■ Specification of tools · Werkzeug Beschreibung

Type Typ	Stock Lager	Dimensions (mm) Abmessungen							Inserts WSP	No. of teeth Zähne	Coupling Aufnahme	Weight Gewicht (kg)		
		R	L	$\varnothing D$	$\varnothing c$	$\varnothing d$	$a_{e\max}$	a_p					H	
SMP03 Arbor mounting	-080×8-A22-MP06-10	○	○	80	45	22	21	8	40	MPHT060304-DM	10	A	0.4	
	-100×8-B27-MP06-14	○	○	100	55	27	24.5	8	40		14	B	0.6	
Arbor Aufnahme	-100×10-B27-MP06-14	●	○	100	55	27	24.5	10	40		14	B	0.7	
	-125×10-B32-MP06-16	○	○	125	65	32	33.3	10	45		16	B	1.1	
	-125×12-B32-MP08-12	○	○	125	65	32	33	12	45		MPHT080305-DM	12	B	1.4
	-160×12-B40-MP08-14	○	○	160	80	40	44	12	50			14	B	1.9
	-200×12-C40-MP08-18	○	○	200	92	40	52	12	50			18	C	3.2
	-125×16-B32-MP12-10	○	○	125	65	32	33	16	50		MPHT120408-DM	10	B	2.3
	-160×16-B40-MP12-12	○	○	160	80	40	45	16	60			12	B	2.3
	-160×18-B40-MP12-12	○	○	160	80	40	45	18	60			12	B	2.4
	-200×16-C40-MP12-14	○	○	200	92	40	52	16	50			14	C	3.6
	-200×18-C40-MP12-14	○	○	200	92	40	52	18	50			14	C	3.9
-200×20-C40-MP12-14	○	○	200	92	40	52	20	50	14			C	4.2	

■ Spare parts · Ersatzteile

Diameter Durchmesser $\varnothing D$	Insert WSP	Screw Schraube	Wrench Schlüssel	
				
$\varnothing 80$ - $\varnothing 125$	MP06	I60M2.5×6.5	WT07IP	
$\varnothing 125$ - $\varnothing 200$	MP08	I60M3×7	WT09P	
$\varnothing 125$ - $\varnothing 200$	MP12	I60M5×13		WT20IS

Applicable tool B11-B18
Werkzeug

Tools code key B26-B27
Werkzeug ISO

Grade selection guide B19-B23
Sortenauswahl

Technical data B215-B220
Technische Daten

Milling · Fräsen

Indexable Milling Tools · Wendepplattenfräser

Applicable inserts · Wendeschneidplatten

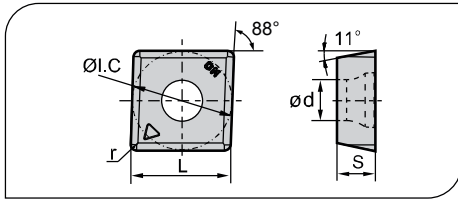

- Ideal Machining Condition / Gute Bearbeitungsbedingungen
- Normal Machining Condition / Normale Bearbeitungsbedingungen
- Unfavorable Machining Condition / Ungünstige Bearbeitungsbedingungen

Workpiece Material / Werkstoff	P	M	K	N	S	YBC301	YBC302	YBC401	YBM251	YBM253	YBM351	YBD152	YBD252	YBG102	YBG202	YBG205	YBG302	YBG152	YBG252	YNG151	YNG151C	YC30S	YD101	YD201
P Steel / Stahl	●	●	●	●	●	●	●	●	●	●	●	●	●	●	●	●	●	●	●	●	●	●	●	●
M Stainless Steel / Rostfreier Stahl	●	●	●	●	●	●	●	●	●	●	●	●	●	●	●	●	●	●	●	●	●	●	●	●
K Cast iron / Gusseisen	●	●	●	●	●	●	●	●	●	●	●	●	●	●	●	●	●	●	●	●	●	●	●	●
N Non-ferrous material / Ne Metalle	●	●	●	●	●	●	●	●	●	●	●	●	●	●	●	●	●	●	●	●	●	●	●	●
S Heat-resistant steel / Warmfester Stahl	●	●	●	●	●	●	●	●	●	●	●	●	●	●	●	●	●	●	●	●	●	●	●	●

Insert WSP	Type Typ	Dimensions (mm) / Abmessungen					CVD Coating / CVD Beschicht.						PVD Coating / PVD Beschicht.				Cermet / Cermet	Carbide uncoat. / unbe. Hartmetall							
		I.C	L	S	d	r	YBC301	YBC302	YBC401	YBM251	YBM253	YBM351	YBD152	YBD252	YBG102	YBG202		YBG205	YBG302	YBG152	YBG252	YNG151	YNG151C	YC30S	YD101
	MPHT060304-DM	6.35	6.35	3.18	2.8	0.4	●	○									●								
	MPHT080305-DM	8.3	8.3	3.18	5.56	0.5	●	○									●								
	MPHT120408-DM	12.7	12.7	4.76	5.56	0.8	●	○									●								

Recommended Cutting data · Schnittdaten

Workpiece material / Werkstückstoff	Hardness HB / Härte	Grade / Sorte	Cutting data / Schnittdaten	
			V(m/min)	f(mm/z)
P Low-carbon steel / Soft steel / Niedriglegierter Kohlenstoffstahl / Baustahl	≤180	YBM251 / YBG202	180 (100-250)	0.1(0.08-0.25)
		YBG302	150 (100-200)	0.15(0.1-0.3)
	180-280	YBM251 / YBG202	150 (80-250)	0.1(0.08-0.25)
		YBG302	120 (80-200)	0.15(0.1-0.3)
	280-350	YBM251 / YBG202	120 (80-250)	0.1(0.08-0.25)
		YBG302	100 (80-200)	0.15(0.1-0.3)
M Stainless steel / Rostfreier Stahl	≤270	YBM251 / YBG202	120 (80-250)	0.1(0.05-0.15)
		YBG302	100 (80-200)	0.08(0.05-0.15)
K Cast iron / Gusseisen	180-250	YBG152	120 (80-250)	0.1(0.05-0.15)
		YBG302	150 (100-250)	0.08(0.05-0.15)

● Ex Stock / ab Lager ○ On demand / auf Anfrage

Groove milling tools · Nutenfräser



SMP05 **P** **M** **K**

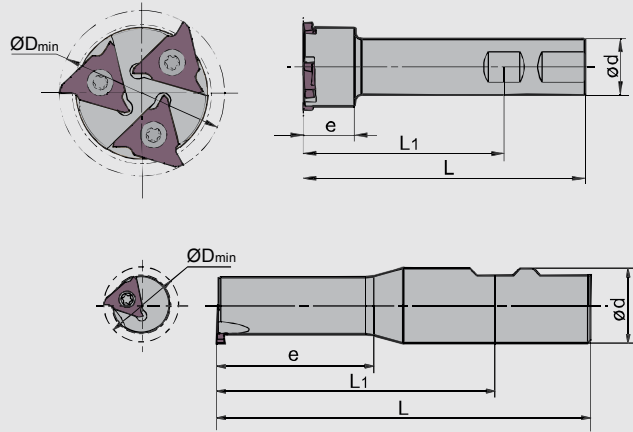

■ Specification of tools · Werkzeug Beschreibung

Type Typ	Stock Lager	Dimensions (mm) Abmessungen					No. of teeth Zähne	Inserts WSP	W(mm)
		ØD _{min}	ød	e	L ₁	L			
SMP05 -025×3.0-XP25-QC16-01	●	25	25	40	89	125	1	QC16L 110~300	1.10-3.00
-039×3.0-XP25-QC16-03	●	39	25	23	89	125	3	QC16L 110~300	1.10-3.00
-044×4.8-XP25-QC22-03	●	44	25	23	89	125	3	QC22L 125~480	1.25-4.8

■ Spare parts · Ersatzteile

Diameter Durchmesser Ø D	Screw Schraube	Wrench Schlüssel
Ø25	I60M3.5×10	WT15IP
Ø39	I60M3.5×10	WT15IP
Ø44	I60M5×13	WT20IP



Applicable tool
Werkzeug

B11-B18

Tools code key
Werkzeug ISO

B26-B27

Grade selection guide
Sortenauswahl

B19-B23

Technical data
Technische Daten

B215-B220

Milling · Fräsen

Indexable Milling Tools · Wendepplattenfräser

Applicable inserts · Wendeschneidplatten

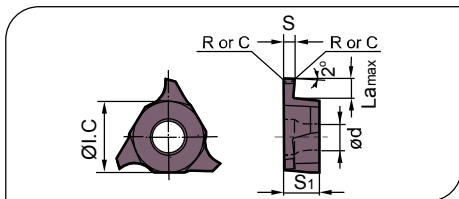

- Ideal Machining Condition / Gute Bearbeitungsbedingungen
- Normal Machining Condition / Normale Bearbeitungsbedingungen
- Unfavorable Machining Condition / Ungünstige Bearbeitungsbedingungen

Workpiece Material / Werkstoffe	P	M	K	N	S	YBC301	YBC302	YBC401	YBM251	YBM253	YBM351	YBD152	YBD252	YBG102	YBG202	YBG205	YBG302	YBG152	YBG252	YNG151	YNG151C	YC30S	YD101	YD201
P Steel / Stahl	●	●	●	●	●	●	●	●	●	●	●	●	●	●	●	●	●	●	●	●	●	●	●	●
M Stainless Steel / Rostfreier Stahl	●	●	●	●	●	●	●	●	●	●	●	●	●	●	●	●	●	●	●	●	●	●	●	●
K Cast iron / Gusseisen	●	●	●	●	●	●	●	●	●	●	●	●	●	●	●	●	●	●	●	●	●	●	●	●
N Non-ferrous material / <i>Ne Metalle</i>	●	●	●	●	●	●	●	●	●	●	●	●	●	●	●	●	●	●	●	●	●	●	●	●
S Heat-resistant steel / Warmfester Stahl	●	●	●	●	●	●	●	●	●	●	●	●	●	●	●	●	●	●	●	●	●	●	●	●

Insert WSP	Type Typ	Dimensions (mm) / Abmessungen						CVD Coating / CVD Beschicht.						PVD Coating / PVD Beschicht.				Cermet Cermet	Carbide uncoat. / unbe. Hartmetall							
		S±0.025	La_max	R/C	ØI.C	S1	ød	YBC301	YBC302	YBC401	YBM251	YBM253	YBM351	YBD152	YBD252	YBG102	YBG202		YBG205	YBG302	YBG152	YBG252	YNG151	YNG151C	YC30S	YD101
	QC16L110-R01	1.10	2.00	R0.1	9.525	3.18	4.4									○	●									
	QC16L125-R02	1.25	2.00	R0.2	9.525	3.18	4.4									○	●									
	QC16L145-R02	1.45	2.00	R0.2	9.525	3.18	4.4									○	●									
	QC16L150-R02	1.50	2.00	R0.2	9.525	3.18	4.4									○	●									
	QC16L175-R02	1.75	2.00	R0.2	9.525	3.18	4.4									○	●									
	QC16L185-R02	1.85	2.50	R0.2	9.525	3.18	4.4									○	●									
	QC16L200-R02	2.00	2.50	R0.2	9.525	3.18	4.4									○	●									
	QC16L250-R02	2.50	2.50	R0.2	9.525	3.18	4.4									○	●									
	QC16L300-R02	3.00	3.00	R0.2	9.525	3.18	4.4									○	●									

● Ex Stock / ab Lager ○ On demand / auf Anfrage

Applicable inserts · Wendeschneidplatten

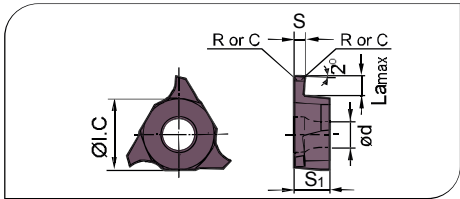

- Ideal Machining Condition / Gute Bearbeitungsbedingungen
- Normal Machining Condition / Normale Bearbeitungsbedingungen
- Unfavorable Machining Condition / Ungünstige Bearbeitungsbedingungen

Workpiece Material / Werkstoffe	P	M	K	N	S
P Steel / Stahl	●	●	●	●	●
M Stainless Steel / Rostfreier Stahl	●	●	●	●	●
K Cast iron / Gusseisen	●	●	●	●	●
N Non-ferrous material / Ne Metalle	●	●	●	●	●
S Heat-resistant steel / Warmfester Stahl	●	●	●	●	●

Insert WSP	Type Typ	Dimensions (mm) / Abmessungen						CVD Coating / CVD Beschicht.						PVD Coating / PVD Beschicht.				Cermet / Cermet	Carbide uncoat. / unbe. Hartmetall								
		S±0.025	Lmax	R/C	ØI.C	S1	ød	YBC301	YBC302	YBC401	YBM251	YBM253	YBM351	YBD152	YBD252	YBG102	YBG202		YBG205	YBG302	YBG152	YBG252	YNG151	YNG151C	YC30S	YD101	YD201
	QC22L125-R02	1.25	2.00	R0.2	12.70	4.76	5.5										○	●									
	QC22L145-R02	1.45	2.00	R0.2	12.70	4.76	5.5										○	●									
	QC22L150-R02	1.50	3.50	R0.2	12.70	4.76	5.5										○	●									
	QC22L175-R02	1.75	3.50	R0.2	12.70	4.76	5.5										○	●									
	QC22L185-R02	1.85	3.50	R0.2	12.70	4.76	5.5										○	●									
	QC22L200-R02	2.00	3.50	R0.2	12.70	4.76	5.5										○	●									
	QC22L230-R02	2.30	3.50	R0.2	12.70	4.76	5.5										○	●									
	QC22L250-R03	2.50	4.00	R0.3	12.70	4.76	5.5										○	●									
	QC22L265-R03	2.65	4.00	R0.3	12.70	4.76	5.5										○	●									
	QC22L280-R03	2.80	4.00	R0.3	12.70	4.76	5.5										○	●									
	QC22L300-R03	3.00	4.00	R0.3	12.70	4.76	5.5										○	●									
	QC22L320-R03	3.20	4.00	R0.3	12.70	4.76	5.5										○	●									
	QC22L330-R03	3.30	4.00	R0.3	12.70	4.76	5.5										○	●									
	QC22L350-R03	3.50	5.00	R0.3	12.70	4.76	5.5										○	●									
	QC22L400-R04	4.00	5.00	R0.4	12.70	4.76	5.5										○	○									
	QC22L430-R04	4.30	5.00	R0.4	12.70	4.76	5.5										○	○									
	QC22L450-R04	4.50	5.00	R0.4	12.70	4.76	5.5										○	○									
	QC22L480-R04	4.80	5.00	R0.4	12.70	5.06	5.5										○	○									

Applicable tool / Werkzeug B11-B18

Tools code key / Werkzeug ISO B26-B27

Grade selection guide / Sortenauswahl B19-B23

Technical data / Technische Daten B215-B220



High feed milling cutters · Hochvorschubfräser

XMR01 P M K



S type insert, straight shank
S Typ WSP, Zylinder Schaft

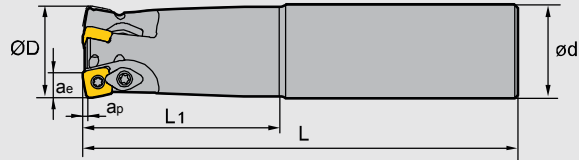

Specification of tools · Werkzeug-Beschreibung With Internal Cooling · Mit Innenkühlung

Type Typ	Stock Lager	Dimensions (mm) Abmessungen							No. of teeth Zähne	Weight Gewicht (kg)
		Ø D	ap	ae	L ₁	L	Ø d			
XMR01 -025-G25-SD09-02	●	25	1.4	8.8	60	140	25	2	0.5	
-025-G25-SD09-02C	●	25	1.4	8.8	60	140	25	2	0.5	
-032-G32-SD09-03	●	32	1.4	8.8	70	150	32	3	0.8	
-032-G32-SD09-03C	●	32	1.4	8.8	70	150	32	3	0.8	
-035-G32-SD09-03	○	35	1.4	8.8	70	150	32	3	0.8	
-035-G32-SD09-03C	○	35	1.4	8.8	70	150	32	3	0.8	
-032-G32-SD12-02	●	32	1.8	11.7	70	150	32	2	0.8	
-032-G32-SD12-02C	●	32	1.8	11.7	70	150	32	2	0.8	
-040-G40-SD12-03	●	40	1.8	11.7	70	150	40	3	1.3	
-040-G40-SD12-03C	●	40	1.8	11.7	70	150	40	3	1.3	

XMR01 P M K

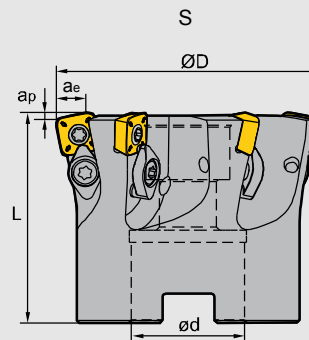

Specification of tools · Werkzeug-Beschreibung With Internal Cooling · Mit Innenkühlung

Type Typ	Stock Lager	Dimensions (mm) Abmessungen						No. of teeth Zähne	Coupling Aufnahme	Weight Gewicht (kg)
		Ø D	ap	ae	L	Ø d				
XMR01 -050-A22-SD09-04	●	50	1.4	8.8	40	22	4	A	0.3	
-050-A22-SD09-04C	●	50	1.4	8.8	40	22	4	A	0.3	
-063-A22-SD09-06	●	63	1.4	8.8	40	22	6	A	0.5	
-063-A22-SD09-06C	●	63	1.4	8.8	40	22	6	A	0.5	
-063-A27-SD09-06	○	63	1.4	8.8	50	27	6	A	0.6	
-063-A27-SD09-06C	○	63	1.4	8.8	50	27	6	A	0.6	
-063-A22-SD12-05	●	63	1.8	11.7	40	22	5	A	0.5	
-063-A22-SD12-05C	●	63	1.8	11.7	40	22	5	A	0.5	
-063-A27-SD12-05	○	63	1.8	11.7	50	27	5	A	0.6	
-063-A27-SD12-05C	○	63	1.8	11.7	50	27	5	A	0.6	
-080-A27-SD12-05	●	80	1.8	11.7	63	27	5	A	0.9	
-080-A27-SD12-05C	●	80	1.8	11.7	63	27	5	A	0.9	
-100-B32-SD12-06	●	100	1.8	11.7	50	32	6	B	1.8	
-100-B32-SD12-06C	●	100	1.8	11.7	50	32	6	B	1.8	

● Ex Stock / ab Lager ○ On demand / auf Anfrage

Milling · Fräsen

Indexable Milling Tools · Wendepplattenfräser

High feed milling cutters · Hochvorschubschafffräser



XMR01 P M K



W type insert, straight shank
W Typ WSP, Zylinder Schaft

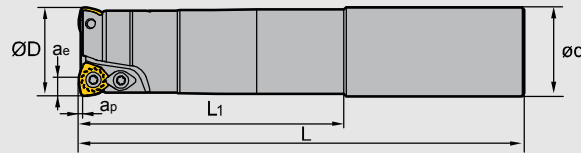

Specification of tools · Werkzeug-Beschreibung

Type Typ	Stock Lager	Dimensions (mm) Abmessungen						No. of teeth Zähne	Weight Gewicht (kg)
		Ø D	ap	ae	L1	L	ø d		
XMR01 -020-G20-WP05-02-M	●	20	1.5	3.8	50	130	20	2	0.2
-020-G20-WP05-02C-M	●	20	1.5	3.8	50	130	20	2	0.2
-020-G20-WP05-02-L	●	20	1.5	3.8	100	180	20	2	0.3
-020-G20-WP05-02C-L	●	20	1.5	3.8	100	180	20	2	0.3
-020-G20-WP05-02-XL	○	20	1.5	3.8	130	250	20	2	0.8
-020-G20-WP05-02C-XL	○	20	1.5	3.8	130	250	20	2	0.8
-025-G25-WP06-02-M	●	25	1.5	4.35	60	140	25	2	0.4
-025-G25-WP06-02C-M	●	25	1.5	4.35	60	140	25	2	0.4
-025-G25-WP06-02-L	○	25	1.5	4.35	120	200	25	2	0.6
-025-G25-WP06-02C-L	○	25	1.5	4.35	120	200	25	2	0.6
-025-G25-WP06-02-XL	○	25	1.5	4.35	180	300	25	2	1.0
-025-G25-WP06-02C-XL	○	25	1.5	4.35	180	300	25	2	1.0
-032-G32-WP06-03-M	●	32	1.5	4.35	70	150	32	3	0.8
-032-G32-WP06-03C-M	●	32	1.5	4.35	70	150	32	3	0.8
-032-G32-WP06-03-L	●	32	1.5	4.35	120	200	32	3	1.0
-032-G32-WP06-03C-L	●	32	1.5	4.35	120	200	32	3	1.0
-032-G32-WP06-03-XL	○	32	1.5	4.35	180	300	32	3	1.6
-032-G32-WP06-03C-XL	○	32	1.5	4.35	180	300	32	3	1.6
-040-G32-WP06-03-M	○	40	1.5	4.35	50	150	32	3	0.9
-040-G32-WP06-03C-M	○	40	1.5	4.35	50	150	32	3	0.9
-040-G32-WP06-03-L	○	40	1.5	4.35	50	250	32	3	1.5
-040-G32-WP06-03C-L	○	40	1.5	4.35	50	250	32	3	1.5
-040-G32-WP06-03-XL	○	40	1.5	4.35	50	300	32	3	1.8
-040-G32-WP06-03C-XL	○	40	1.5	4.35	50	300	32	3	1.8
-040-G32-WP08-02-M	○	40	1.5	5.66	50	150	32	2	0.9
-040-G32-WP08-02C-M	○	40	1.5	5.66	50	150	32	2	0.9
-040-G32-WP08-02-L	○	40	1.5	5.66	50	250	32	2	1.5
-040-G32-WP08-02C-L	○	40	1.5	5.66	50	250	32	2	1.5
-040-G32-WP08-02-XL	○	40	1.5	5.66	50	300	32	2	1.9
-040-G32-WP08-02C-XL	○	40	1.5	5.66	50	300	32	2	1.9
-050-G32-WP09-02-M	○	50	3.0	6.8	50	150	32	2	1.9
-050-G32-WP09-02C-M	○	50	3.0	6.8	50	150	32	2	1.9
-050-G32-WP09-02-L	○	50	3.0	6.8	50	250	32	2	2.5
-050-G32-WP09-02C-L	○	50	3.0	6.8	50	250	32	2	2.5

Spare parts · Ersatzteile

Tool Werkzeug	Clamp/Insert Screw Schraube	Clamp Pratze	Wrench Schlüssel	
XMR01**-WP05**	I60M3,5x08TT	--	WT10P	--
XMR01**-WP06**	I60M4x8.4	--	WT15P	--
XMR01**-WP08**	I60M5x13	WD-208	--	WT20IT
XMR01**-WP09**				

● Ex Stock / ab Lager ○ On demand / auf Anfrage

High feed milling cutters · Hochvorschubfräser



XMR01 P M K



W type insert, Arbor mounting
W Typ WSP, Aufsteckfräser

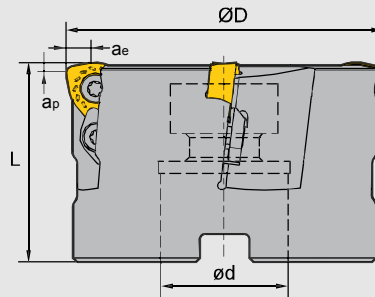

Specification of tools · Werkzeug-Beschreibung

Type Typ	Stock Lager	Dimensions (mm) Abmessungen					No. of teeth Zähne	Inserts WSP	Weight Gewicht (kg)
		Ø D	ap	ae	L	ø d			
XMR01 -050-A22-WP06-04	●	50	1.5	4.35	50	22	4	A	0.4
-050-A22-WP06-04C	●	50	1.5	4.35	50	22	4	A	0.4
-050-A22-WP08-03	○	50	1.5	5.66	50	22	3	A	0.4
-050-A22-WP08-03C	○	50	1.5	5.66	50	22	3	A	0.4
-063-A22-WP08-04	●	63	1.5	5.66	50	22	4	A	0.7
-063-A22-WP08-04C	●	63	1.5	5.66	50	22	4	A	0.7
-063-A27-WP08-04	●	63	1.5	5.66	50	27	4	A	0.7
-063-A27-WP08-04C	●	63	1.5	5.66	50	27	4	A	0.7
-080-A27-WP08-05	●	80	1.5	5.66	63	27	5	A	1.5
-080-A27-WP08-05C	●	80	1.5	5.66	63	27	5	A	1.5
-100-B32-WP08-06	○	100	1.5	5.66	63	32	6	B	2.2
-100-B32-WP08-06C	○	100	1.5	5.66	63	32	6	B	2.2
-125-B40-WP08-07	●	125	1.5	5.66	63	40	7	B	3.5
-125-B40-WP08-07C	●	125	1.5	5.66	63	40	7	B	3.5
-160-B40-WP08-08	○	160	1.5	5.66	63	40	8	B	6.0
-160-B40-WP08-08C	○	160	1.5	5.66	63	40	8	B	6.0
-063-A22-WP09-03	○	63	3.0	6.8	50	22	3	A	0.7
-063-A22-WP09-03C	○	63	3.0	6.8	50	22	3	A	0.7
-080-A27-WP09-04	○	80	3.0	6.8	63	27	4	A	1.4
-080-A27-WP09-04C	○	80	3.0	6.8	63	27	4	A	1.4
-100-B32-WP09-05	○	100	3.0	6.8	63	32	5	B	2.1
-100-B32-WP09-05C	○	100	3.0	6.8	63	32	5	B	2.1
-125-B40-WP09-06	○	125	3.0	6.8	63	40	6	B	3.7
-125-B40-WP09-06C	○	125	3.0	6.8	63	40	6	B	3.7
-160-B40-WP09-07	○	160	3.0	6.8	63	40	7	B	6.3
-160-B40-WP09-07C	○	160	3.0	6.8	63	40	7	B	6.3

Spare parts · Ersatzteile

Tool Werkzeug	Clamp / Insert Screw Pratze / WSP Schraube	Clamp Pratze	Wrench Schlüssel	
XMR01**-WP06**	I60M4×8.4	--	WT15S	--
XMR01**-WP08**	I60M5×13	WD-208	--	WT20IT
XMR01**-WP09**	I60M5×13	WD-208	--	



Applicable tool B11-B18
Werkzeug

Tools code key B26-B27
Werkzeug ISO

Grade selection guide B19-B23
Sortenauswahl

Technical data B215-B220
Technische Daten

Milling · Fräsen

Indexable Milling Tools · Wendeplattenfräser

Applicable inserts · Wendschneidplatten

● Ideal Machining Condition / Gute Bearbeitungsbedingungen
● Normal Machining Condition / Normale Bearbeitungsbedingungen
● Unfavorable Machining Condition / Ungünstige Bearbeitungsbedingungen

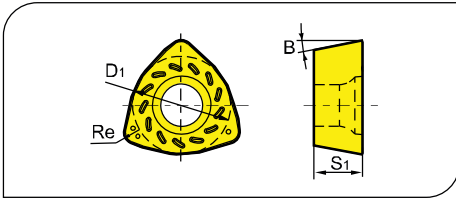

Workpiece Material / Werkstoffe	P	M	K	N	S	YBC301	YBC302	YBC401	YBM251	YBM253	YBM351	YBD152	YBD252	YBG102	YBG202	YBG205	YBG212	YBG152	YBG252	YNG151	YNG151C	YC30S	YD101	YD201
P Steel / Stahl	●	●	●	●	●	●	●	●	●	●	●	●	●	●	●	●	●	●	●	●	●	●	●	●
M Stainless Steel / Rostfreier Stahl	●	●	●	●	●	●	●	●	●	●	●	●	●	●	●	●	●	●	●	●	●	●	●	●
K Cast iron / Gusseisen	●	●	●	●	●	●	●	●	●	●	●	●	●	●	●	●	●	●	●	●	●	●	●	●
N Non-ferrite material / <i>Ne Metalle</i>	●	●	●	●	●	●	●	●	●	●	●	●	●	●	●	●	●	●	●	●	●	●	●	●
S Heat-resistant steel / <i>Warmfester Stahl</i>	●	●	●	●	●	●	●	●	●	●	●	●	●	●	●	●	●	●	●	●	●	●	●	●

Insert WSP	Type Typ	Dimensions (mm) / Abmessungen				CVD Coating / CVD Beschicht.						PVD Coating / PVD Beschicht.				Cermet / Cermet	Carbide uncoat. / unbe. Hartmetall								
		B	Re	S1	D1	YBC301	YBC302	YBC401	YBM251	YBM253	YBM351	YBD152	YBD252	YBG102	YBG202		YBG205	YBG212	YBG152	YBG252	YNG151	YNG151C	YC30S	YD101	YD201
	WPGT050315ZSR	11°	1.5	3.5	7.94	●					●						○								
	WPGT060415ZSR	11°	1.5	4.2	9.525	●					●						●	○							
	WPGT080615ZSR	11°	1.5	6.35	12.85	●					●						●	○							
	WPGT090725ZSR	11°	2.5	7	15	●					●							○							
	WPGT050315ZSR-PM	11°	1.5	3.5	7.94	●					○					●									
	WPGT060415ZSR-PM	11°	1.5	4.2	9.525	●					○						●								
	WPGT080615ZSR-PM	11°	1.5	6.35	12.85	●					○						●								
	WPGT090725ZSR-PM	11°	2.5	7	15	●					○						●								

● Ex Stock / ab Lager ○ On demand / auf Anfrage

Approximate R in machining program Ungefährer Programmerradius

Insert WSP	approx. ca. R(mm)	Cutting margin Cutting margin K(mm)
WPGT050315ZSR	2	0.5
WPGT060415ZSR	2.5	0.7
WPGT080615ZSR	2.0	0.7
WPGT090725ZSR	4.0	1.2
SDMT09T312-DM	2.5	0.87
SDMT120412-DM	4.0	0.93

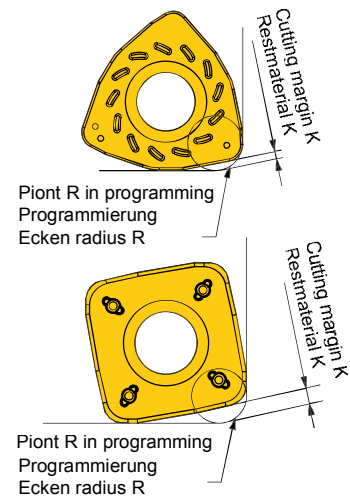

Different machining styles Different machining styles

■ Ramp machining Tauchfräsen

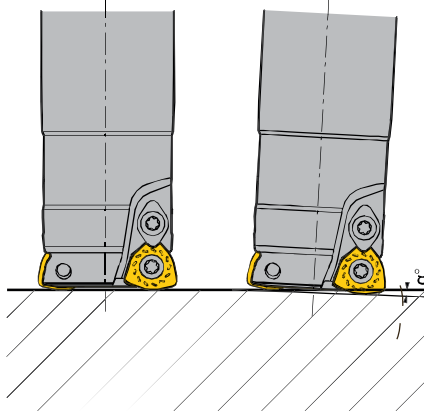

■ Helical interpolation milling Zirkularfräsen

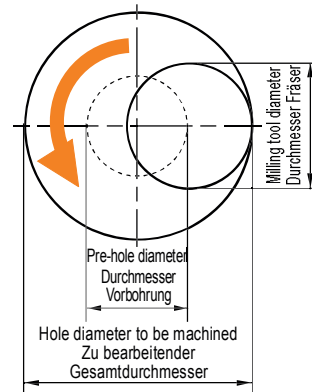

- Reduce the feed rate in ramp and helical machining operations.
- Set the axial feed rate below 0.2mm/rev in drilling operation.
- Be careful ! Long chippings may fly out in drilling operation.
- The cutting depth of each rotation can't exceed the maximum cutting depth (a_p)
- The S type insert not only is applied in the machining operations mentioned above, but also able to be used for plunge milling.

- Beim Tauch- und Zirkularfräsen den Vorschub reduzieren.
- Vorschub bei Bohroperationen (achsial) unter 0,2 mm einstellen.
- "Vorsicht" – Beim Bohren können lange Späne entstehen.
- Die Schnitttiefe pro Rotation kann die maximale Schnitttiefe a_p nicht erreichen.
- Die S-Type Wendschneidplatten können auch für andere Bearbeitungsoperationen eingesetzt werden.

XMR01-Serie XMR01-Serie

XMR01 series tools (install SD**inserts) possess perfect edge strength and excellent economical efficiency, have more advantages in face milling.

XMR01 series tools (install WP**inserts) possess good capability of chip removal, have more advantages in cavity milling.

Werkzeuge mit Schneidplatten (SD**) besitzen ausgezeichnete Schneidkantenstabilität. Sie haben besondere Vorteile beim Planfräsen mit hoher Wirtschaftlichkeit.

Werkzeuge mit Schneidplatten (WP..) haben besondere Vorteile bei der Spanabfuhr und werden Löschen beim Auskoffern eingesetzt.

Milling · Fräsen

Indexable Milling Tools · Wendeplattenfräser

B

Milling Tools
Fräser

Recommended Cutting data · Schnittdaten

Workpiece material Werkstückstoff	Hardness HB Härte	Grade Sorte	Cutting speed Schnitt- geschw. (m/min)	Ø25		Ø30/32/35		
				Axial cutting depth Axial cutting depth	Feed rate per tooth Feed rate per tooth	Axial cutting depth Axial cutting depth	Feed rate per tooth Feed rate per tooth	
P carbon steel Soft steel legierter Kohlenstoffstahl Baustahl	≤HB180 HB180- 280	YBG202	170(120-220)	0.6~1.0	0.8~1.2	0.8~1.2	1.0~1.4	
		YBM351	150(100-200)					
	Alloy steel Leg. Stahl Alloy tool steel Leg. Werkzeugstahl	HB280-350 ≤HB350	YBG202	150(100-200)	0.4~0.8	0.8~1.2	0.6~1.0	1.0~1.4
			YBM351	130(80-180)				
	hardened steel gehärteter Stahl	≤HRC35	YBG202	150(100-200)	0.4~0.8	0.6~1.0	0.6~1.0	0.8~1.2
			YBM351	120(80-160)				
M Stainless steel Rostfreier Stahl	≤HB270	YBG202	150(100-200)	0.6~1.0	0.6~1.0	0.8~1.2	0.8~1.2	
		YBM351	120(80-160)					
K cast Iron Gusseisen	Tensile strength Tensile strength ≤350MPa	YBG202	170(120-220)	0.6~1.0	1.0~1.4	0.8~1.2	1.2~1.6	
		YBM351	150(100-200)					
	Nodular Cast iron Kugelgrafitguss Temperguss	Tensile strength Tensile strength ≤800MPa	YBG202	150(100-200)	0.4~0.8	0.8~1.2	0.6~1.0	1.0~1.4
			YBM351	120(80-160)				

Recommended Cutting data · Schnittdaten

Workpiece material Werkstückstoff	Hardness HB Härte	Grade Sorte	Cutting speed Schnitt- geschw. (m/min)	Ø40		Ø50/63		Ø80/100		
				Axial cutting depth Axial cutting depth	Feed rate per tooth Feed rate per tooth	Axial cutting depth Axial cutting depth	Feed rate per tooth Feed rate per tooth	Axial cutting depth Axial cutting depth	Feed rate per tooth Feed rate per tooth	
P carbon steel Soft steel legierter Kohlenstoffstahl Baustahl	≤HB180 HB180- 280	YBG202	170(120-220)	0.8~1.2	1.0~1.4	1.1~1.5	1.1~1.5	1.0~1.5	1.0~1.5	
		YBM351	150(100-200)							
	Alloy steel Leg. Stahl Alloy tool steel Leg. Werkzeugstahl	HB280-350 ≤HB350	YBG202	150(100-200)	0.6~1.0	1.0~1.4	0.9~1.3	1.1~1.5	0.8~1.3	1.0~1.5
			YBM351	130(80-180)						
	hardened steel gehärteter Stahl	≤HRC35	YBG202	150(100-200)	0.6~1.0	0.8~1.2	0.9~1.3	0.9~1.3	0.8~1.3	0.8~1.3
			YBM351	120(80-160)						
M Stainless steel Rostfreier Stahl	≤HB270	YBG202	150(100-200)	0.8~1.2	0.8~1.2	1.1~1.5	0.9~1.3	1.0~1.5	0.8~1.3	
		YBM351	120(80-160)							
K cast Iron Gusseisen	Tensile strength Tensile strength ≤350MPa	YBG202	170(120-220)	0.8~1.2	1.2~1.6	1.1~1.5	1.3~1.7	1.0~1.5	1.2~1.7	
		YBM351	150(100-200)							
	Nodular Cast iron Kugelgrafitguss Temperguss	Tensile strength Tensile strength ≤800MPa	YBG202	150(100-200)	0.6~1.0	1.0~1.4	0.9~1.3	1.1~1.5	0.8~1.3	1.0~1.5
			YBM351	120(80-160)						

● Ex Stock / ab Lager ○ On demand / auf Anfrage

XMR01 series high feed milling tools Hochvorschubfräser

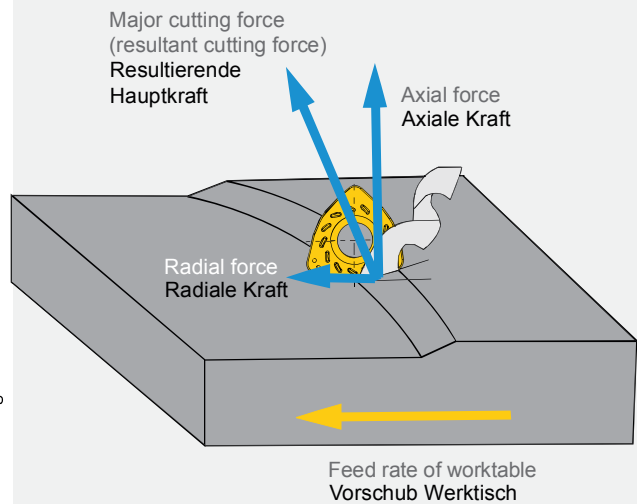
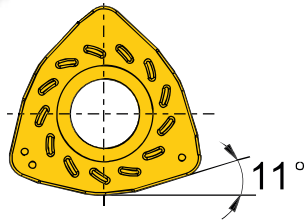

The feature of high feed tool is to resolve the major cutting force into the axial direction, greatly reduce the radial cutting force, thus improve tool's capability of shock resistance. In addition, this structure can effectively reduce the vibration in long overhang milling application.

Merkmale dieses Hochvorschubfräasers ist die Ablenkung der Hauptkraft in axiale Richtung. Dadurch wird die radiale Kraft deutlich verringert, was eine Reduzierung der Vibration ermöglicht und somit lange Standzeiten auch bei größeren Auskräglängen zur Folge hat.



XMP01

Boring and milling
Bohren und Fräsen

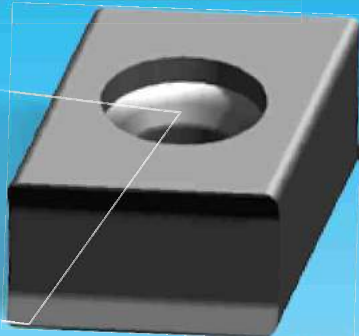
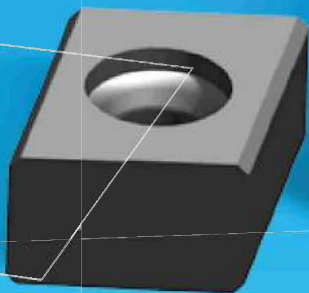

XMP01 Feature XMP01 Eigenschaft

- Complex function milling, mainly use for large-diameter hole and cavity profile milling;
- Versatility for face milling and side milling in $kr=90^\circ$
- Vertical insert, two types of chipbreaker for different materials and machining operations.
- Universal Fräser für die Bearbeitung von großen Bohrungen;
- Auch für den Einsatz von Planfräsen und Eckfräsen geeignet;
- Vertikale Wendschneidplatte. Zwei WSP-Geometrien für verschiedene Materialien und Bearbeitungen

Boring milling cutters · Bohren und Fräsen



XMP01 P M K

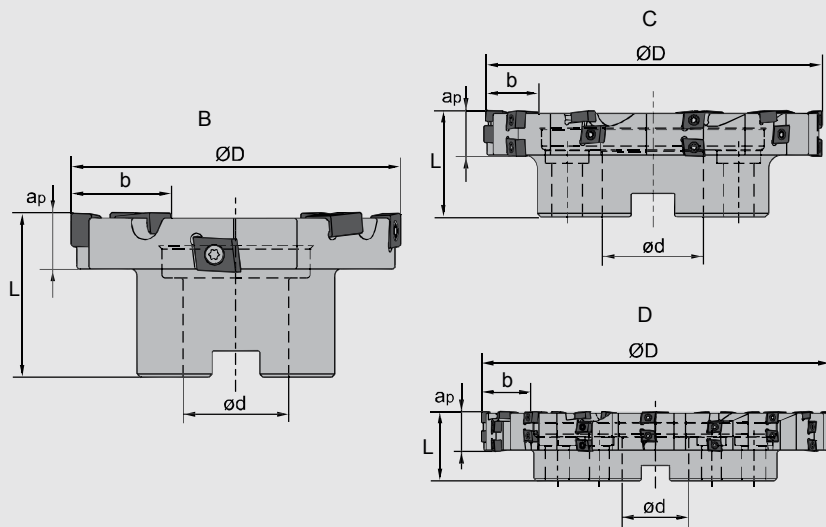



Specification of tools · Werkzeug Beschreibung

Type Typ	Stock Lager	Dimensions (mm) Abmessungen					No. of teeth Zähne Z	Zeff (peripheral teeth/end teeth) (Eckplatte / Planplatte)	Coupling Aufnahme	Weight Gewicht (kg)
		ØD	ød	L	b	ap				
XMP01 -080X18-B27-CNE1210-08	●	80	27	50	18	15	8	2/2	B	0.67
-100X18-B32-CNE1210-08	●	100	32	50	18	20	8	2/2	A	0.99
-125X27-B40-CNE1210-15	●	125	40	63	27	22.5	15	3/2	B	2.46
-160X27-C40-CNE1210-18	●	160	40	63	27	25	18	4/2	C	3.7
-200X27-C60-CNE1210-21	●	200	60	63	27	31.5	21	5/2	C	5.46
-250X36-C60-CNE1210-32	○	250	40	63	36	56.5	32	6/2	C	9.79
-315X36-D60-CNE1210-42	○	315	60	63	36	47.5	42	8/2	D	17.65
-400X36-D60-CNE1210-52	○	400	60	63	36	90	52	10/2	D	27.36

Remark: (1) special ap,b,D possible on request of the Customers
(1) besondere ap,b,D möglich nach Anfrageen

(2) Zeff means the effeptive teeth
(2) Zeff bedeutet die wirkungsvolle zähne

Spare parts · Ersatzteile

Diameter Durchmesser φD	Insert WSP	Clamp Screw Schraube	Wrench Schlüssel	
				
Ø80-Ø400	CNE121006*	I60M4X12	WT15IP	

Applicable tool B11-B18
Werkzeug

Tools code key B26-B27
Werkzeug ISO

Grade selection guide B19-B23
Sortenauswahl

Technical data B215-B220
Technische Daten

Kr:90°



T-slot milling tools · T-Nuten Fräser

TMP01 K

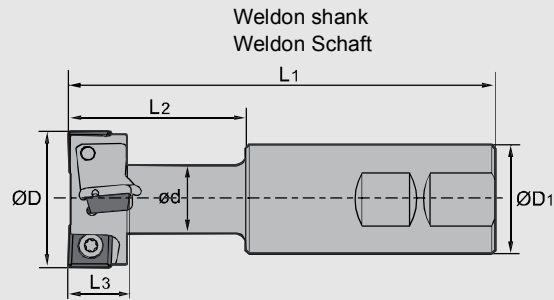

■ Specification of tools · Werkzeug-Beschreibung

Type Typ	Stock Lager	Dimensions (mm) Abmessungen							No. of teeth Zähne	Number of insert Anzahl WSP	T-slot specification für T-Nuten
		Ø D	Ø D1	ø d	L1	L2	L3				
TMP01											
-021-XP25-MP06-01	●	21	25	10	100	32	9	1	2	12	
-025-XP25-MP06-01	●	25	25	12	100	35	11	1	2	14	
-032-XP32-MP08-02	●	32	32	15	110	45	14	2	4	18	
-040-XP32-MP12-02	●	40	32	19	125	55	18	2	4	22	
-050-XP40-MP12-02	●	50	40	25	140	65	22	2	4	28	
-060-XP50-MP12-02	●	60	50	32	160	80	28	2	6	36	

■ Spare parts · Ersatzteile

Tool Werkzeug	Screw Schraube	Wrench Schlüssel	
TMP01-021-XP25-MP06-01	I60M2.5×5.5	WT07IP	--
TMP01-025-XP25-MP06-01	I60M2.5×5.5		
TMP01-032-XP32-MP08-02	I60M3×7	WT10IP	--
TMP01-040-XP32-MP12-02	I60M5×10	--	WT20IT
TMP01-050-XP40-MP12-02	I60M5×10		
TMP01-060-XP50-MP12-02	I60M5×10		

Applicable tool B11-B18
Werkzeug

Tools code key B26-B27
Werkzeug ISO

Grade selection guide B19-B23
Sortenauswahl

Technical data B215-B220
Technische Daten

Milling · Fräsen

Indexable Milling Tools · Wendeplattenfräser

Applicable inserts · Wendschneidplatten

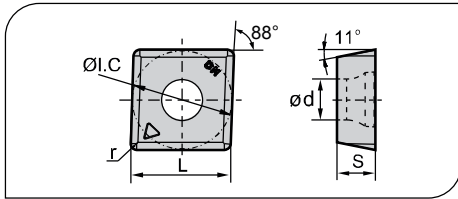

- Ideal Machining Condition / Gute Bearbeitungsbedingungen
- Normal Machining Condition / Normale Bearbeitungsbedingungen
- Unfavorable Machining Condition / Ungünstige Bearbeitungsbedingungen

Workpiece Material / Werkstoff	P	M	K	N	S
Steel / Stahl	●	●	●	●	●
Stainless Steel / Rostfreier Stahl	●	●	●	●	●
Cast iron / Gusseisen	●	●	●	●	●
Non-ferrite material / <i>Ne Metalle</i>	●	●	●	●	●
Heat-resistant steel / <i>Warmfester Stahl</i>	●	●	●	●	●

Insert WSP	Type Typ	Dimensions (mm) / Abmessungen					CVD Coating / CVD Beschicht.						PVD Coating / PVD Beschicht.			Cermet / Cermet	Carbide uncoat. / unbe. Hartmetall									
		I.C	L	s	d	r	YBC301	YBC302	YBC401	YBM251	YBM253	YBM351	YBD152	YBD252	YBG102		YBG202	YBG205	YBG302	YBG152	YBG252	YNG151	YNG151C	YC30S	YD101	YD201
	MPHT060304-DM	6.35	6.35	3.18	2.8	0.4	●	○										●								
	MPHT080305-DM	8.3	8.3	3.18	3.4	0.5	●	○										●								
	MPHT120408-DM	12.7	12.7	4.76	5.56	0.8	●	○										●								

Recommended Cutting data · Schnittdaten

Workpiece material / Werkstückstoff	Grade / Sorte	Cutting data / Schnittdaten		
		V(m/min)	f(mm/z)	Cooling / Kühlung
K	YBG302	80~160	0.05~0.2	Wet / Dry / Nass/ Trocken

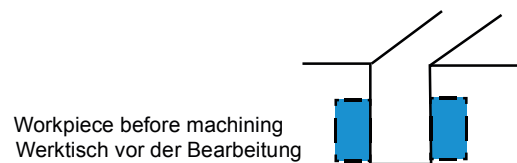

● Ex Stock / ab Lager ○ On demand / auf Anfrage

Helical end mill · Walzenstirnfräser

Kr:90°

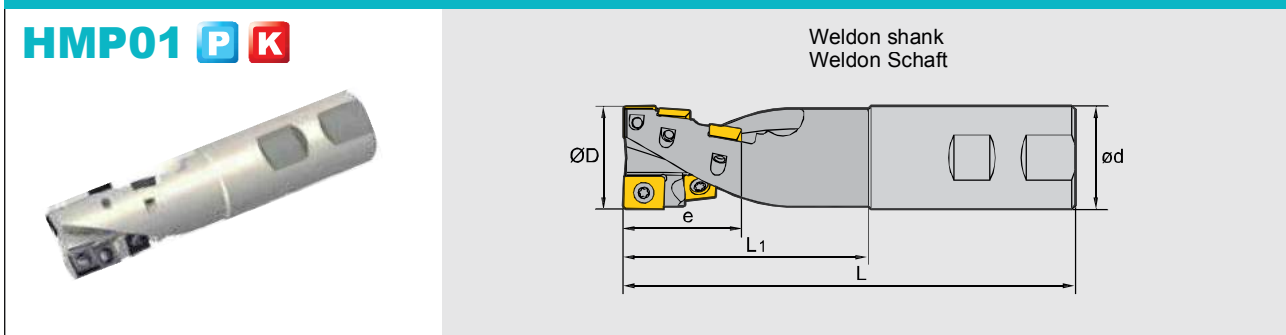

■ Specification of tools · Werkzeug-Beschreibung

Type Typ	Stock Lager		Dimensions (mm) Abmessungen					Number of flute Anzahl Zahnreihen Z	Number of insert Anzahl WSP		Shank type Schaft
	R	L	Ø D	ø d	e	L ₁	L		APKT 150412-**	SPMT 120408-**	
HMP01 -040×55-XP40-SP12-02	●	○	40	40	55	95	175	2	1	5	Weldon Weldon
-050×55-XP40-SP12-04	●	○	50	40	55	95	175	4	2	10	Weldon Weldon

■ Spare parts · Ersatzteile

Diameter Durchmesser Ø D	Screw Schraube	Wrench Schlüssel
Ø40	I60M5×10	WT20IS
Ø50	I60M5×13	WT20IS



Applicable tool
Werkzeug

B11-B18

Tools code key
Werkzeug ISO

B26-B27

Grade selection guide
Sortenauswahl

B19-B23

Technical data
Technische Daten

B215-B220

Helical end mill · Walzenstirnfräser

Kr:90°



HMP01 P K



JT shank/BT shank (figure is JT shank)
JT Schaft/BT Schaft (Abb. is JT shank)

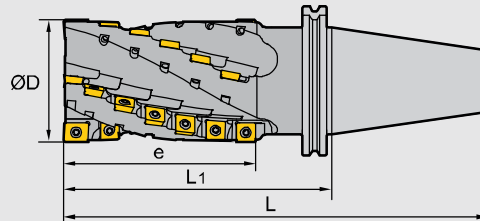

Specification of tools · Werkzeug-Beschreibung

Type Typ	Stock Lager		Dimensions (mm) Abmessungen				Number of flute Anzahl Zahnreihen Z	Number of insert Anzahl WSP		Shank type Schaft	
	R	L	Ø D	e	L ₁	L		APKT 150412-**	SPMT 120408-**		
HMP01	-050×84-JT50-SP12-04	○	○	50	84	145	246.75	4	2	16	JT
	-063×74-JT50-SP12-04	○	○	63	74	135	236.75	4	2	14	JT
	-063×104-JT50-SP12-04	●	○	63	104	165	266.75	4	2	20	JT
	-063×134-JT50-SP12-04	○	○	63	134	195	296.75	4	2	26	JT
	-080×104-JT50-SP12-04	○	○	80	104	165	266.75	4	2	20	JT
	-080×144-JT50-SP12-04	○	○	80	144	205	306.75	4	2	28	JT
	-050×84-BT50-SP12-04	○	○	50	84	145	246.8	4	2	16	BT
	-063×74-BT50-SP12-04	○	○	63	74	135	236.8	4	2	14	BT
	-063×104-BT50-SP12-04	○	○	63	104	165	266.8	4	2	20	BT
	-063×134-BT50-SP12-04	○	○	63	134	195	296.8	4	2	26	BT
	-080×104-BT50-SP12-04	○	○	80	104	165	266.8	4	2	20	BT
	-080×144-BT50-SP12-04	○	○	80	144	205	306.8	4	2	28	BT

Spare parts · Ersatzteile

Diameter Durchmesser Ø D	Screw Schraube	Wrench Schlüssel	
Ø50	I60M5×13	WT20IS	
Ø63	I60M5×13	WT20IS	
Ø80	I60M5×13	WT20IS	

● Ex Stock / ab Lager ○ On demand / auf Anfrage

Helical endmills with interchangeable heads Walzenstirnfräser mit austauschbarem Kopf

Kr:90°



HMP01 EC P K

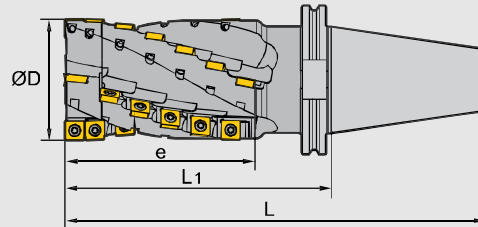

Specification of tools · Werkzeug-Beschreibung

Type Typ	Stock Lager		Dimensions (mm) Abmessungen				Number of flute Anzahl Zahnreihen Z	Number of insert Anzahl WSP		Shank type Schaft	
	R	L	Ø D	e	L1	L		APKT 150412-**	SPMT 120408-**		
HMP01	-050×84EC-JT50-SP12-04	●	○	50	84	145	246.75	4	2	16	JT
	-063×74EC-JT50-SP12-04	○	○	63	74	135	236.75	4	2	14	JT
	-063×104EC-JT50-SP12-04	○	○	63	104	165	266.75	4	2	20	JT
	-063×134EC-JT50-SP12-04	●	○	63	134	195	296.75	4	2	26	JT
	-080×104EC-JT50-SP12-04	○	○	80	104	165	266.75	4	2	20	JT
	-080×144EC-JT50-SP12-04	○	○	80	144	205	306.75	4	2	28	JT
	-050×84EC-BT50-SP12-04	○	○	50	84	145	246.8	4	2	16	BT
	-063×74EC-BT50-SP12-04	○	○	63	74	135	236.8	4	2	14	BT
	-063×104EC-BT50-SP12-04	○	○	63	104	165	266.8	4	2	20	BT
	-063×134EC-BT50-SP12-04	○	○	63	134	195	296.8	4	2	26	BT
	-080×104EC-BT50-SP12-04	○	○	80	104	165	266.8	4	2	20	BT
	-080×144EC-BT50-SP12-04	○	○	80	144	205	306.8	4	2	28	BT

Spare parts · Ersatzteile

Diameter Durchmesser Ø D	Insert Screw WSP Schraube	Screw of head Schraube für Kopf	Wrench of insert Screw Schlüssel f. WSP	Wrench of head Schlüssel für Kopf	Interchangeable head Austauschbarer Kopf	
Ø50	I60M5×13	M10×50	WT20IS	WH80L	050EC	
Ø63	I60M5×13	M10×50	WT20IS	WH80L	063EC	
Ø80	I60M5×13	M12×55	WT20IS	WH100L	080EC	

Applicable tool B11-B18
Werkzeug

Tools code key B26-B27
Werkzeug ISO

Grade selection guide B19-B23
Sortenauswahl

Technical data B215-B220
Technische Daten

Milling - Fräsen

Indexable Milling Tools - Wendepplattenfräser

Applicable inserts · Wendeschneidplatten

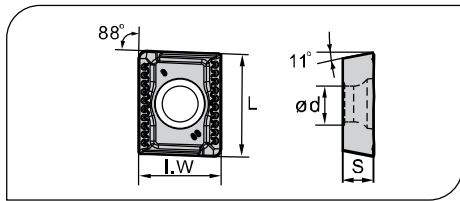

- Ideal Machining Condition / Gute Bearbeitungsbedingungen
- Normal Machining Condition / Normale Bearbeitungsbedingungen
- Unfavorable Machining Condition / Ungünstige Bearbeitungsbedingungen

Workpiece Material / Werkstoffe	CVD Coating / CVD Beschicht.							PVD Coating / PVD Beschicht.					Cermet / Cermet	Carbide uncoat. / unbe. Hartmetall		
	YBC301	YBC302	YBC401	YBM251	YBM253	YBM351	YBD152	YBD252	YBG102	YBG202	YBG205	YBG302			YBG152	YBG252
P Steel / Stahl	●	●	●	●	●	●	●	●	●	●	●	●	●	●	●	●
M Stainless Steel / Rostfreier Stahl	●	●	●	●	●	●	●	●	●	●	●	●	●	●	●	●
K Cast iron / Gussisen								●	●			●	●			●
N Non-ferite material / Ne Metalle																●
S Heat-resistant steel / Warmfester Stahl								●	●		●	●				

Insert WSP	Type Typ	Dimensions (mm) / Abmessungen					CVD Coating / CVD Beschicht.						PVD Coating / PVD Beschicht.					Cermet / Cermet	Carbide uncoat. / unbe. Hartmetall						
		L	I.W	S	d	r	YBC301	YBC302	YBC401	YBM251	YBM253	YBM351	YBD152	YBD252	YBG102	YBG202	YBG205			YBG302	YBG152	YBG252			
	APKT150412-PM	16.33	12.7	4.76	5.4	1.2					●							●							
	APKT150412-KM	16.33	12.7	4.76	5.4	1.2												○	●						

Applicable inserts · Wendeschneidplatten

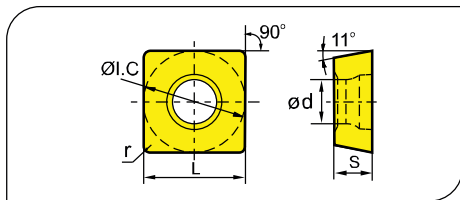

- Ideal Machining Condition / Gute Bearbeitungsbedingungen
- Normal Machining Condition / Normale Bearbeitungsbedingungen
- Unfavorable Machining Condition / Ungünstige Bearbeitungsbedingungen

Workpiece Material / Werkstoffe	CVD Coating / CVD Beschicht.							PVD Coating / PVD Beschicht.					Cermet / Cermet	Carbide uncoat. / unbe. Hartmetall		
	YBC301	YBC302	YBC401	YBM251	YBM253	YBM351	YBD152	YBD252	YBG102	YBG202	YBG205	YBG302			YBG152	YBG252
P Steel / Stahl	●	●	●	●	●	●	●	●	●	●	●	●	●	●	●	●
M Stainless Steel / Rostfreier Stahl	●	●	●	●	●	●	●	●	●	●	●	●	●	●	●	●
K Cast iron / Gussisen								●	●			●	●			●
N Non-ferite material / Ne Metalle																●
S Heat-resistant steel / Warmfester Stahl								●	●		●	●				

Insert WSP	Type Typ	Dimensions (mm) / Abmessungen					CVD Coating / CVD Beschicht.						PVD Coating / PVD Beschicht.					Cermet / Cermet	Carbide uncoat. / unbe. Hartmetall						
		L	I.W	S	d	r	YBC301	YBC302	YBC401	YBM251	YBM253	YBM351	YBD152	YBD252	YBG102	YBG202	YBG205			YBG302	YBG152	YBG252			
	SPMT120408-PM	12.7	12.7	4.76	5.5	0.8					●								●						
	SPMT120408-KM	12.7	12.7	4.76	5.5	0.8													○	●					

● Ex Stock / ab Lager ○ On demand / auf Anfrage

A Slot milling
Nutenfräsen

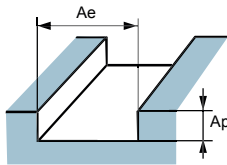

$A_e = D$
 $A_p = 0.5D$ (cast iron/Guss)
Maximum 12mm (steel/Stahl)

B Square shoulder milling
breites Eckfräsen

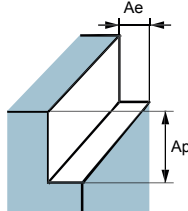

$A_e = 0.5D$
 $A_p = 1.5D$ (cast iron/Guss)
1.0D (steel/Stahl)

C Narrow shoulder milling
schmales Eckfräsen

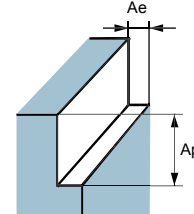

$A_e = 0.1D$
 $A_p \leq$ Maximum cutting length
Maximale Schnittlänge

Recommended Cutting data · Schnittdaten

Workpiece material Werkstückstoff	Hardness HB Härte	Grade Sorte	Cutting data Schnittdaten		Operation (figure/Abb.) Operation (figure/Abb.)	
			Cutting speed Schnittgeschw. (m/min)	Feed speed Vorschub (mm/z)		
P Low-carbon steel Soft steel niedriglegierter Kohlenstoffstahl Baustahl	≤ 180	YBG302	80(60-90)	0.25(0.1-0.35)	A	
			90(70-120)	0.3(0.15-0.4)	B	
			90(70-120)	0.3(0.15-0.4)	C	
	High-carbon steel hochlegierter Kohlenstoffstahl Alloysteel Leg. Stahl	180-280	YBG302	70(60-100)	0.2(0.1-0.35)	A
				80(60-120)	0.25(0.15-0.35)	B
				90(70-120)	0.25(0.15-0.35)	C
	Alloy tool steel Leg. Werkzeugstahl	280-350	YBG302	50(40-80)	0.15(0.08-0.25)	A
				60(50-100)	0.2(0.1-0.35)	B
				70(50-100)	0.2(0.1-0.35)	C
K cast Iron Gusseisen	180-250	YBG152 YBG302	70(50-100)	0.2(0.1-0.35)	A	
			80(60-120)	0.25(0.15-0.35)	B	
			90(80-120)	0.25(0.15-0.35)	C	

Chamfer milling tools · Fasfräser

Kr:30°



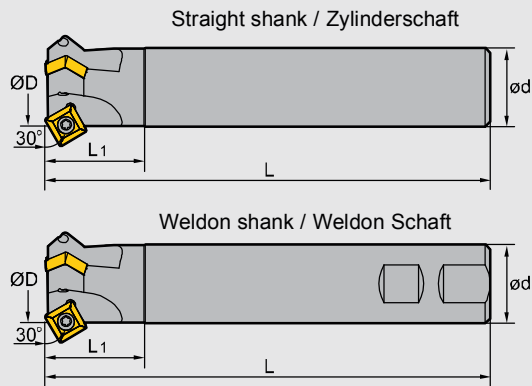

CMZ01 P M K



■ Specification of tools · Werkzeug-Beschreibung

	Type Typ	Stock Lager	Dimensions (mm) Abmessungen				No. of teeth Zähne	Weight Gewicht (kg)
			Ø D	ø d	L	L ₁		
CMZ01 Zylinder- schaft	-012-G20-SP12-01	●	12	20	100	40	1	0.2
	-025-G25-SP12-02	●	25	25	120	40	2	0.8
	-032-G32-SP12-03	●	32	32	180	40	3	1.1
Weldon Schaft	-012-XP20-SP12-01	●	12	20	100	40	1	0.2
	-025-XP25-SP12-02	●	25	25	120	40	2	0.6
Weldon Schaft	-032-XP32-SP12-03	●	32	32	180	40	3	1.0

■ Spare parts · Ersatzteile

Diameter Durchmesser Ø D	Screw Schraube	Wrench Schlüssel
Ø12-Ø32	 I43M5×11	 WT20IS



● Ex Stock / ab Lager ○ On demand / auf Anfrage

Kr:45°



Chamfer milling tools · Fasträser

CMA01 P M K

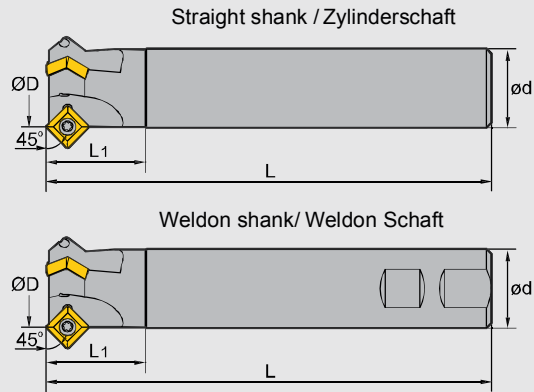

■ Specification of tools · Werkzeug-Beschreibung

	Type Typ	Stock Lager	Dimensions (mm) Abmessungen				No. of teeth Zähne	Weight Gewicht (kg)
			Ø D	ø d	L	L1		
Straight shank	CMA01 -012-G20-SP12-01	●	12	20	100	40	1	0.2
	-025-G25-SP12-02	●	25	25	120	40	2	0.8
Zylinder Schaft	-032-G32-SP12-03	●	32	32	180	40	3	1.1
Weldon shank	-012-XP20-SP12-01	●	12	20	100	40	1	0.2
Weldon Schaft	-025-XP25-SP12-02	●	25	25	120	40	2	0.6
	-032-XP32-SP12-03	●	32	32	100	40	3	1.0

■ Spare parts · Ersatzteile

Diameter Durchmesser Ø D	Screw Schraube	Wrench Schlüssel
Ø12-Ø32	I43M5×11	WT20IS



Applicable tool B11-B18
Werkzeug

Tools code key B26-B27
Werkzeug ISO

Grade selection guide B19-B23
Sortenauswahl

Technical data B215-B220
Technische Daten

Chamfer milling tools · Fasfräser

Kr:60°



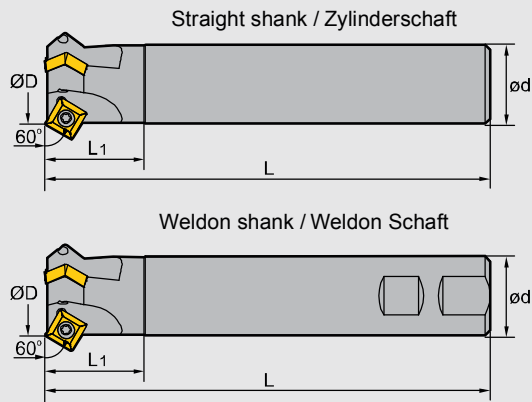

CMD01 P M K



■ Specification of tools · Werkzeug-Beschreibung

	Type Typ	Stock Lager	Dimensions (mm) Abmessungen				No. of teeth Zähne	Weight Gewicht (kg)
			Ø D	ø d	L	L ₁		
CMD01 Straight shank	-012-G20-SP12-01	●	12	20	100	40	1	0.2
	-025-G25-SP12-02	●	25	25	120	40	2	0.8
	Zylinder Schaft	-036-G32-SP12-03	●	36	32	180	40	3
Weldon shank	-012-XP20-SP12-01	●	12	20	100	40	1	0.2
	-025-XP25-SP12-02	●	25	25	120	40	2	0.6
	Weldon Schaft	-036-XP32-SP12-03	●	36	32	180	40	3

■ Spare parts · Ersatzteile

Diameter Durchmesser Ø D	Screw Schraube	Wrench Schlüssel
Ø12-Ø32	 I43M5×11	 WT20IS



● Ex Stock / ab Lager ○ On demand / auf Anfrage

■ Applicable inserts · Wendeschneidplatten

● Ideal Machining Condition
Gute Bearbeitungsbedingungen
● Normal Machining Condition
Normale Bearbeitungsbedingungen
● Unfavorable Machining Condition
Ungünstige Bearbeitungsbedingungen

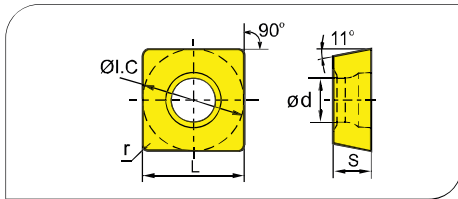

Workpiece Material Werkstoffe	P	M	K	N	S	YBC301	YBC302	YBC401	YBM251	YBM253	YBM351	YBD152	YBD252	YBG102	YBG202	YBG205	YBG302	YBG152	YBG252	YNG151	YNG151C	YC30S	YD101	YD201
Steel Stahl	●	●	●	●	●	●	●	●	●	●	●	●	●	●	●	●	●	●	●	●	●	●	●	●
Stainless Steel Rostfreier Stahl	●	●	●	●	●	●	●	●	●	●	●	●	●	●	●	●	●	●	●	●	●	●	●	●
Cast iron Gusseisen	●	●	●	●	●	●	●	●	●	●	●	●	●	●	●	●	●	●	●	●	●	●	●	●
Non-ferrous material Nichtmetalle	●	●	●	●	●	●	●	●	●	●	●	●	●	●	●	●	●	●	●	●	●	●	●	●
Heat-resistant steel Wärmebeständiger Stahl	●	●	●	●	●	●	●	●	●	●	●	●	●	●	●	●	●	●	●	●	●	●	●	●

Insert WSP	Type Typ	Dimensions (mm) Abmessungen					CVD Coating CVD Beschicht.						PVD Coating PVD Beschicht.			Cermets Cermets	Carbide uncoat. unbe. Hartmetall								
		I.C.	L	r	S	d	YBC301	YBC302	YBC401	YBM251	YBM253	YBM351	YBD152	YBD252	YBG102		YBG202	YBG205	YBG302	YBG152	YBG252	YNG151	YNG151C	YC30S	YD101
	SPMT120408	12.7	12.7	0.8	4.76	5.5	●	○	●									●							

Recommended Cutting data · Schnittdaten

Workpiece material Werkstückstoff	Hardness HB Härte	Grade Sorte	Cutting data Schnittdaten	
			Cutting speed Schnittgeschw. (m/min)	Feed speed Vorschub (mm/z)
P Low-carbon steel Soft steel niedriglegierter Kohlenstoffstahl Baustahl High-carbon steel hochlegierter Kohlenstoffstahl Alloy steel Leg. Stahl Alloy tool steel Leg. Werkzeugstahl	≤180	YBM251 YBC301	180(100—250)	0.25 (0.1-0.4)
		YBM351 YBG302 YBC401	150(100—200)	0.3 (0.1-0.5)
		YC30S	120(80—150)	0.4 (0.1-0.5)
	180—280	YBM251 YBC301	160(100—220)	0.3 (0.1-0.4)
		YBM351 YBG302 YBC401	130(100—180)	0.3 (0.1-0.5)
		YC30S	100(60—150)	0.4 (0.1-0.5)
	280—350	YBM251 YBC301	120(80—180)	0.3 (0.1-0.4)
		YBM351 YBG302	100(80—150)	0.3 (0.1-0.5)
		YC30S	80(60—120)	0.4 (0.1-0.5)
M Stainless steel Rostfreier Stahl	≤270	YBM251 YBC301	120(80—180)	0.3 (0.1-0.4)
		YBM351 YBG302 YBC401	100(80—150)	0.3 (0.1-0.5)
		YC30S	80(60—120)	0.4 (0.1-0.5)
K Cast iron Gusseisen	180-250	YBG302	130(100—180)	0.4 (0.1-0.5)

Applicable tool B11-B18
Werkzeug

Tools code key B26-B27
Werkzeug ISO

Grade selection guide B19-B23
Sortenauswahl

Technical data B215-B220
Technische Daten

- Different tool holders in carbide and steel are available for the QCH-SERIES
- Carbide tool holder reduces vibrations and performs very well in high feed operations and in operations where a big overhang is required.
- All exchangeable heads are available with inner coolant hole (except QCH-ZOHX)
- Different connection are available (M8,M10,M12,M16)

- Verschiede Verlängerungen in Stahl oder Hartmetall sind für die QCH-SERIE verfügbar.
- HM- Verlängerung reduziert Vibrationen und steigert die Performance bei hohen Vorschüben und Anwendungen in denen große Auskraglängen benötigt werden.
- Alle Austauschköpfe sind für die Anwendung mit Innenkühlung ausgelegt (ausgenommen QCH-ZOHX)
- Verschiedene Gewindeanschlüsse sind verfügbar (M8,M10,M12,M16)

QCH SERIES

QCH SERIE

Steel tool holder
Stahl Verlängerung

Carbide tool holder
Hartmetall Verlängerung

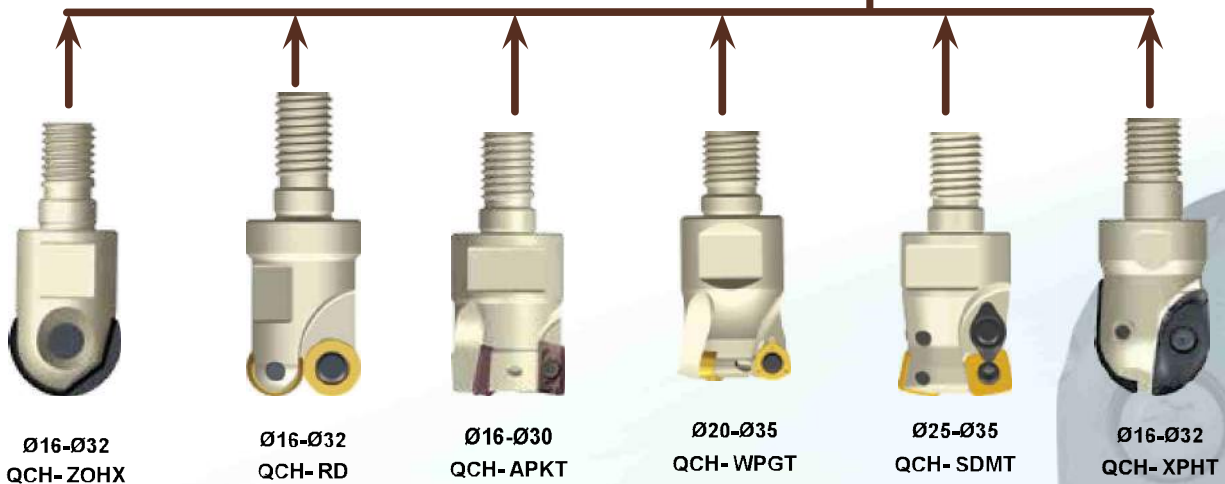

Advantages Vorteile

- Fast tool change reduces setup times
 - Stable force type connection
 - Reduces storage costs
 - Increases flexibility in your machining shop
-
- Schneller Werkzeugwechsel reduziert Rüstzeit und somit Maschinenstillstand.
 - Stabile Kraftschlussverbindung
 - Verringerung der Lagerkosten
 - Erhöht die Flexibilität in der Fertigung





Areas of Application

Mold and Die
Automotive Industry
Energy Sector
Aerospace Industry



Anwendungsgebiete

Werkzeugen und Formenbau
Automotive
Energiesektor
Luft- & Raumfahrt



Overview QCH milling program Übersicht QCH Fräsprogramm

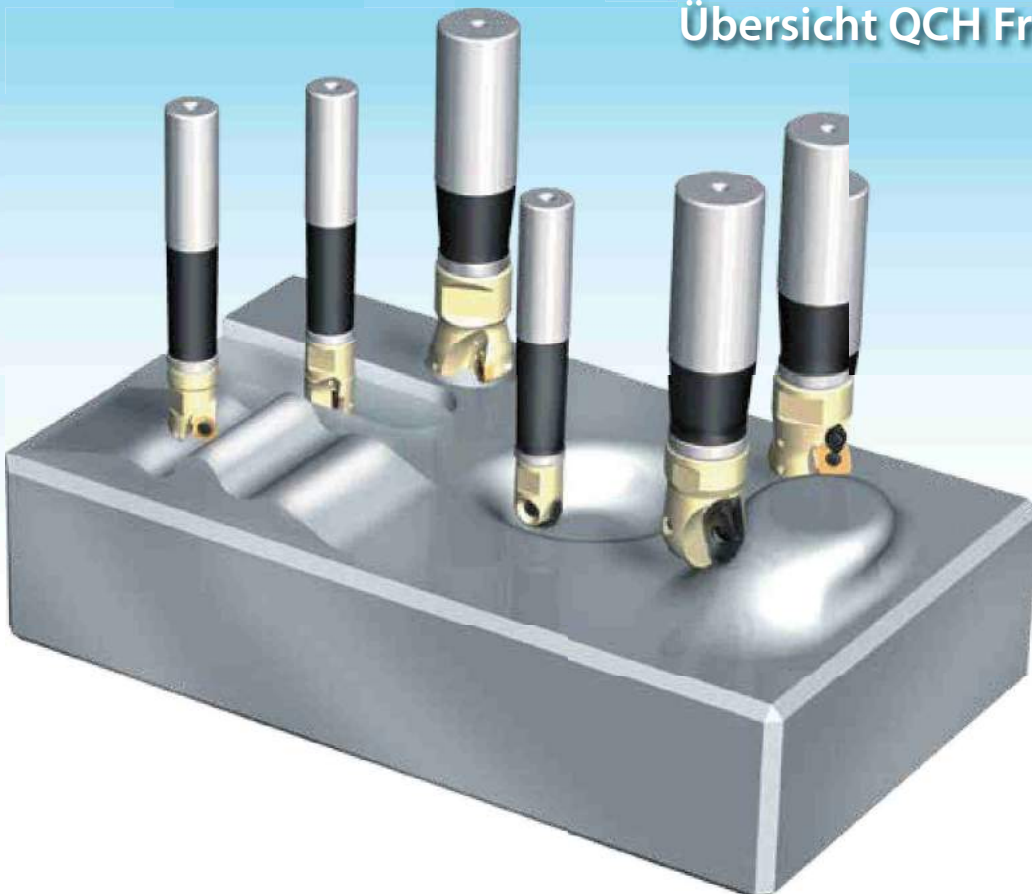

Reassembling with high precision Hohe Wechselgenauigkeit



Test radial runout and axial runout with 2 measuring devices.

Vermessung des axialen und radialen Laufs mit 2 Feinzeigern.

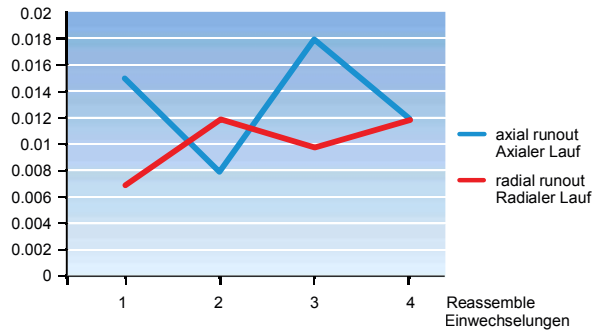

After several times reassembling, the difference between axial- and radial runout is less than 0.02mm

Nach mehreren Auswechselungen ist die Abweichung im radialeb sowie axialen Lauf nur sher gering (<0.02mm)

Efficient tool Charging
Effizientes Werkzeugwechselln

QCH Tools Repalcement
QCH Werkzeugwechsel

Traditional Repalcement
Traditionelles Auswechseln



Material Material	1Cr12Ni2MoVNNb-5
Cooling system Kühlsystem	dry cutting trocken
Machine Maschine	CNC (HSK63 adapter)
Cutting data Schnittdaten	$V_c=150\text{m/min}$ $a_p=2\text{mm}$ $f_z=0.2\text{mm/z}$ $a_e=3\text{mm}$
Machining Bearbeitung	bottom and sidewall Grund- und Sietenfläche

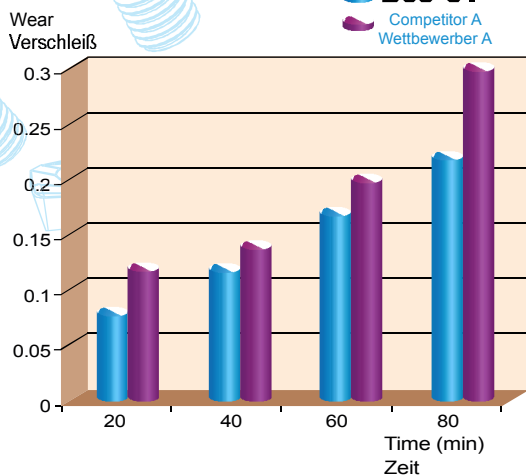
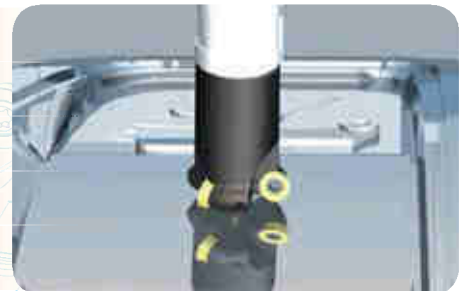

Wear comparison
Verschleißvergleich



ZCC-CT



Competitor A
Wettbewerber A

after 80 min. profile milling
nach 80 Min. Formfräsern

Milling · Fräsen

Indexable Milling Tools · Wendepplattenfräser

Diameter range

Durchmesser Bereich Ø16- Ø20

Recommended Cutting data · Schnittdaten

Operations Anwendung						
Workpiece material Werkstückstoff	Cutting data Schnittdaten	Machining of slot Nutenfräsen	Side milling (slight) Schulterfräsen		Side milling (deep) Schulterfräsen	Grade Sorte
Medium carbon steel Kohlenstoffstahl Hardness Härte 150~250HB	V(m/min)	150~220	150~220	150~220	150~220	YBG302
	Fz(mm/z)	0.1~0.4	0.1~0.4	0.1~0.4	0.1~0.4	
	a _p (mm)	4	4	8	16	
	a _e (mm)	--	3	4	1.5	
Alloy steel Leg. Stahl Hardness Härte 150~280HB	V(m/min)	100~150	100~150	100~150	100~150	
	Fz(mm/z)	0.1~0.4	0.1~0.4	0.1~0.4	0.1~0.4	
	a _p (mm)	4	4	8	16	
	a _e (mm)	--	3	4	1.5	
Die steel Gesenkstahl Hardness Härte 150~255HB	V(m/min)	80~120	80~120	80~120	80~120	
	Fz(mm/z)	0.1~0.3	0.1~0.3	0.1~0.3	0.1~0.3	
	a _p (mm)	4	4	8	16	
	a _e (mm)	--	3	4	1.5	
Hardened steel gehärteter Stahl Hardness Härte 40~50HRC	V(m/min)	80~100	80~100	80~100	--	
	Fz(mm/z)	0.08~0.15	0.08~0.15	0.08~0.15	--	
	a _p (mm)	4	4	8	--	
	a _e (mm)	--	2	3	--	
Grey Cast iron Grauguss Hardness Härte 160~260HB	V(m/min)	250~300	250~300	250~300	250~300	
	Fz(mm/z)	0.08~0.15	0.08~0.15	0.08~0.15	0.08~0.15	
	a _p (mm)	4	4	8	16	
	a _e (mm)	--	3	4	1.5	
Nodular Cast iron Kugelgraphitguss Hardness Härte 170~300HB	V(m/min)	200~250	200~250	200~250	200~250	
	Fz(mm/z)	0.08~0.15	0.08~0.15	0.08~0.15	0.08~0.15	
	a _p (mm)	4	4	8	16	
	a _e (mm)	--	3	4	1.5	

● Ex Stock / ab Lager ○ On demand / auf Anfrage

Recommended Cutting data - Schnittdaten

Diameter range
Durchmesser Bereich $\varnothing 25, \varnothing 30, \varnothing 32$

Operations Anwendung						
Workpiece material Werkstückstoff	Cutting data Schnittdaten	Machining of slot Nutenfräsen	Side milling (slight) Schulterfräsen		Side milling (deep) Schulterfräsen	Grade Sorte
Medium carbon steel Kohlenstoffstahl Hardness Härte 150~250HB	V(m/min)	150~220	150~220	150~220	150~220	YBG302
	Fz(mm/z)	0.1~0.4	0.1~0.4	0.1~0.4	0.1~0.4	
	a _p (mm)	6	6	12.5	25	
	a _e (mm)	--	5	6.5	3	
Alloy steel leg. Stahl Hardness Härte 150~280HB	V(m/min)	100~150	100~150	100~150	100~150	
	Fz(mm/z)	0.1~0.4	0.1~0.4	0.1~0.4	0.1~0.4	
	a _p (mm)	6	6	12.5	25	
	a _e (mm)	--	5	6.5	3	
Die steel Gesenkstahl Hardness Härte 150~255HB	V(m/min)	80~120	80~120	80~120	80~120	
	Fz(mm/z)	0.1~0.3	0.1~0.3	0.1~0.3	0.1~0.3	
	a _p (mm)	6	6	12.5	25	
	a _e (mm)	--	5	6.5	3	
Hardened steel gehärteter Stahl Hardness Härte 40~50HRC	V(m/min)	80~100	80~100	80~100	--	
	Fz(mm/z)	0.08~0.15	0.08~0.15	0.08~0.15	--	
	a _p (mm)	6	6	12.5	--	
	a _e (mm)	--	5	6.5	--	
Grey Cast iron Grauguss Hardness Härte 160~260HB	V(m/min)	250~300	250~300	250~300	250~300	
	Fz(mm/z)	0.08~0.15	0.08~0.15	0.08~0.15	0.08~0.15	
	a _p (mm)	6	6	12.5	25	
	a _e (mm)	--	5	6.5	3	
Nodular Cast iron Kugelgrafitguss Hardness Härte 170~300HB	V(m/min)	200~250	200~250	200~250	200~250	
	Fz(mm/z)	0.08~0.15	0.08~0.15	0.08~0.15	0.08~0.15	
	a _p (mm)	6	6	12.5	25	
	a _e (mm)	--	5	6.5	3	

Milling · Fräsen

Indexable Milling Tools · Wendeplattenfräser

QCH - SDMT



P M K

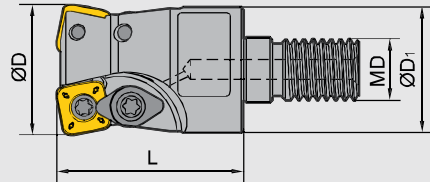

Type Typ	Type Lager	Dimensions (mm) Abmessungen				Insert WSP	No. of teeth Zähne (Z)	Weight Gewicht (kg)	
		ØD	ØD ₁	L	MD				
QCH	-25-SDMT09-M12-02	●	25	24	35	12	SDMT09T312-DM	2	0.088
	-30-SDMT09-M16-03	●	30	29	45	16		3	0.176
	-32-SDMT12-M16-02	●	32	30	45	16	SDMT120412-DM	2	0.175
	-35-SDMT12-M16-02	●	35	30	45	16		2	0.200
	-35-SDMT09-M16-03	●	35	30	45	16	SDMT09T312-DM	3	0.216

■ Spare parts · Ersatzteile

Diameter Durchmesser Ø D	No. of teeth Zähne (Z)	Clamp screw Schraube	Clamp Pratze	Insert Screw WSPSchraube	Wrench Schlüssel
Ø25	2	I60M3.5×08TT	WD-204	I60M4×8.4	WT10IP
Ø30	3				
Ø32	2	I60M4×8.4	WD-204	I60M4×8.4	WT15IP
Ø35	2				
Ø35	3	I60M3.5×08TT	WD-204	I60M4×8.4	WT10IP



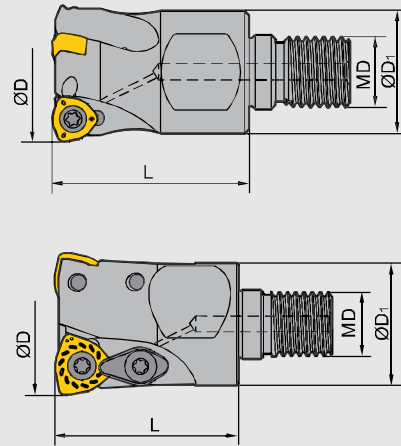

● Ex Stock / ab Lager ○ On demand / auf Anfrage

QCH - WPGT



	Type Typ	Type Lager	Dimensions (mm) Abmessungen				Insert WSP	No. of teeth Zähne (Z)	Weight Gewicht (kg)
			ØD	ØD ₁	L	MD			
QCH	-20-WPGT05-M10-02	●	20	18	30	10	WPGT050315ZSR	2	0.056
	-25-WPGT06-M12-02	●	25	21	35	12	WPGT060415ZSR	2	0.097
	-32-WPGT06-M16-03	●	32	29	43	16	WPGT060415ZSR	3	0.185
	-35-WPGT08-M16-02	●	35	30	45	16	WPGT080615ZSR	2	0.196
	-35-WPGT08-M16-03	●	35	30	45	16	WPGT080615ZSR	3	0.201
	-42-WPGT06-M16-04	●	42	29	43	16	WPGT060415ZSR	4	-

■ Spare parts · Ersatzteile

Diameter Durchmesser Ø D	No. of teeth Zähne (Z)	Clamp screw Schraube	Clamp Pratze	Wrench Schlüssel
Ø20	2	 I60M3.5×7	 --	 WT15
Ø25	2	I60M4×8.4	--	WT15P
Ø32	3	I60M4×8.4	--	WT15P
Ø35	2	I60M5×13	WD-208	WT20IT
Ø35	3	I60M4×8.4	--	WT15P



Applicable tool B11-B18
Werkzeug

Tools code key B26-B27
Werkzeug ISO

Grade selection guide B19-B23
Sortenauswahl

Technical data B215-B220
Technische Daten

Milling · Fräsen

Indexable Milling Tools · Wendepplattenfräser



B

Milling Tools
Fräser

● Ideal Machining Condition / Gute Bearbeitungsbedingungen
● Normal Machining Condition / Normale Bearbeitungsbedingungen
● Unfavorable Machining Condition / Ungünstige Bearbeitungsbedingungen

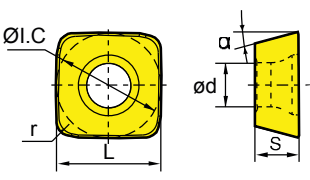
■ Applicable inserts · Wendeschneidplatten





Insert WSP	Type Typ	Dimensions (mm) Abmessungen						CVD Coating CVD Beschicht.						PVD Coating PVD Beschicht.			Cemet Cemet	Carbide uncoat. unbe. Hartmetall									
		ØI.C	L	ød	S	r	α	YBC301	YBC302	YBC401	YBM251	YBM253	YBM351	YBD152	YBD252	YBG102		YBG202	YBG205	YBG302	YBG152	YBG252	YNG151	YNG151C	YC30S	YD101	YD201
	SDMT09T312-DM	9.525	9.525	4.0	3.97	1.2	15°	●					●	○		●	●										
	SDMT120412-DM	12.7	12.7	4.4	4.76	2.0	15°						●	○		●	●										
	SDMT09T312-PM	9.525	9.525	1.2	3.97	4.0	15°	○				●				●	○										
	SDMT120412-PM	12.7	12.7	2.0	4.76	4.4	15°	○				●				●	○										

● Ideal Machining Condition / Gute Bearbeitungsbedingungen
● Normal Machining Condition / Normale Bearbeitungsbedingungen
● Unfavorable Machining Condition / Ungünstige Bearbeitungsbedingungen

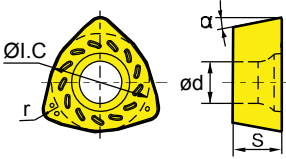
■ Applicable inserts · Wendeschneidplatten



Insert WSP	Type Typ	Dimensions (mm) Abmessungen						CVD Coating CVD Beschicht.						PVD Coating PVD Beschicht.			Cemet Cemet	Carbide uncoat. unbe. Hartmetall								
		ØI.C	r	S	ød	α	YBC301	YBC302	YBC401	YBM251	YBM253	YBM351	YBD152	YBD252	YBG102	YBG202		YBG205	YBG302	YBG152	YBG252	YNG151	YNG151C	YC30S	YD101	YD201
	WPGT050315ZSR	7.94	1.5	3.5	4.0	11°	●					●														
	WPGT060415ZSR	9.525	1.5	4.2	4.4	11°	●					●					●									
	WPGT080615ZSR	12.85	1.5	6.35	5.5	11°	●					●						●								
	WPGT090725ZSR	15	2.5	7	5.5	11°	●					●							●							
	WPGT050315ZSR-PM	7.94	1.5	3.5	4.0	11°	●					○					●									
	WPGT060415ZSR-PM	9.525	1.5	4.2	4.4	11°	●					○					●									
	WPGT080615ZSR-PM	12.85	1.5	6.35	5.5	11°	●					○					●									
	WPGT090725ZSR-PM	15.00	2.5	7.00	5.5	11°	●					○					●									

● Ex Stock / ab Lager ○ On demand / auf Anfrage

Recommended cutting data · Empfohlene Schnittdaten

Workpiece material Werkstück Material	Hardness HB Härte	Grade Sorte	V(m/min)	Ø25		Ø30/32/35	
				Axial cutting depth	f (mm/z)	Axial cutting depth	f (mm/z)
P Low-carbon steel Soft steel Niedrig legierter Kohlenstoffstahl Baustahl	≤HB180 HB180-280	YBC302/YBM351	170(120-220)	0.6~1.0	0.8~1.2	0.8~1.2	1.0~1.4
			150(100-200)				
			Hoch-carbon steel; Alloysteel Hoch Leg. Kohlenstoffstahl; Leg. Stah				
Alloy tool steel Leg. Stahl	≤HRC35	YBC302/YBM351	120(80-160)	0.4~0.8	0.6~1.0	0.6~1.0	0.8~1.2
M Stainless steel Rostfreier Stahl	≤HB270	YBM351	120(80-160)	0.6~1.0	0.6~1.0	0.8~1.2	0.8~1.2
		YBG205	120(80-190)				
K Cast iron Gusseisen	Tensile strength Zugfestigkeit ≤350MPa	YBG302	150(100-200)	0.6~1.0	1.0~1.4	0.8~1.2	1.2~1.6
		Nodular cast iron Kugelgraphitguss Temperguss	Tensile strength Zugfestigkeit ≤800MPa				

Applicable tool **B11-B18**
Werkzeug

Tools code key **B26-B27**
Werkzeug ISO

Grade selection guide **B19-B23**
Sortenauswahl

Technical data **B215-B220**
Technische Daten

Milling · Fräsen

Indexable Milling Tools · Wendeplattenfräser

QCH - APKT



P M K N

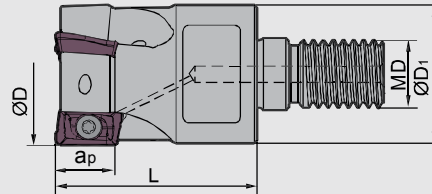

Type Typ	Stock Lager	Dimensions (mm) Abmessungen					Insert WSP	No. of teeth Zähne (Z)	Weight Gewicht (kg)
		ØD	ØD ₁	L	a _p	MD			
QCH	●	16	12.5	25	10.5	8	APKT11T3**	2	0.028
-16-APKT11-M8-02	●	20	18	30	10.5	10		3	0.059
-20-APKT11-M10-03	●	25	21	35	10.5	12		4	0.104
-25-APKT11-M12-04	●	32	29	43	10.5	16		5	-
-32-APKT11-M16-05	●	40	29	43	10.5	16		6	-
-40-APKT11-M16-06	●	25	21	38	10.5	12		APKT1604**	2
-25-APKT16-M12-02	●	32	29	46	10.5	16	3		-
-32-APKT16-M16-03	●	40	29	46	10.5	16	4		-
-40-APKT16-M16-04	●								

■ Spare parts · Ersatzteile

Diameter Durchmesser Ø D	No. of teeth Zähne (Z)	Insert Screw Schraube	Wrench Schlüssel
Ø16	2	I60M2.5×6.5T	WT08IP
Ø20	3		
Ø25	3		
Ø25	2	I60M4×8.4	WT15IP
Ø30	3		



● Ex Stock / ab Lager ○ On demand / auf Anfrage

Milling - Fräsen

Indexable Milling Tools - Wendepplattenfräser

Applicable inserts · Wendeschneidplatten

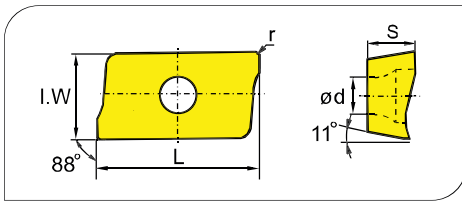

- Ideal Machining Condition / Gute Bearbeitungsbedingungen
- Normal Machining Condition / Normale Bearbeitungsbedingungen
- Unfavorable Machining Condition / Ungünstige Bearbeitungsbedingungen

Workpiece Material / Werkstoffe	P	M	K	N	S	YBC301	YBC302	YBC401	YBM251	YBM253	YBM351	YBD152	YBD252	YBG102	YBG202	YBG205	YBG302	YBG152	YBG252	YNG151	YNG151C	YC30S	YD101	YD201	
P Steel / Stahl	●	●	●	●	●	●	●	●	●	●	●	●	●	●	●	●	●	●	●	●	●	●	●	●	●
M Stainless Steel / Rostfreier Stahl	●	●	●	●	●	●	●	●	●	●	●	●	●	●	●	●	●	●	●	●	●	●	●	●	●
K Cast iron / Guss Eisen	●	●	●	●	●	●	●	●	●	●	●	●	●	●	●	●	●	●	●	●	●	●	●	●	●
N Non-ferrous material / Ne Metalle	●	●	●	●	●	●	●	●	●	●	●	●	●	●	●	●	●	●	●	●	●	●	●	●	●
S Heat-resistant steel / Warmfester Stahl	●	●	●	●	●	●	●	●	●	●	●	●	●	●	●	●	●	●	●	●	●	●	●	●	●

Insert shape / Plattenform	Type / Typ	Dimensions (mm) / Abmessungen					CVD Coating / CVD Beschicht.						PVD Coating / PVD Beschicht.					Cermet / Cermet	Carbide uncoat. / unbe. Hartmetall						
		L	I.W	S	d	r	YBC301	YBC302	YBC401	YBM251	YBM253	YBM351	YBD152	YBD252	YBG102	YBG202	YBG205		YBG302	YBG152	YBG252	YNG151	YNG151C	YC30S	YD101
	APKT11T304-PF	12.24	6.5	3.6	2.8	0.4	○			●															
	APKT11T308-PF	12.24	6.5	3.6	2.8	0.8				○															
	APKT11T312-PF	12.24	6.5	3.6	2.8	1.2																			
	APKT11T316-PF	12.24	6.5	3.6	2.8	1.6																			
	APKT160408-PF	17.877	9.33	5.76	4.4	0.8	●			○		●													
	APKT11T304-PM	12.24	6.5	3.6	2.8	0.4	●	●	●	●		●													
	APKT11T308-PM	12.24	6.5	3.6	2.8	0.8	●	●	●	●	●	●	●	●	●	●	●	●	●	●	●	●	●	●	●
	APKT11T312-PM	12.24	6.5	3.6	2.8	1.2				○															
	APKT11T316-PM	12.24	6.5	3.6	2.8	1.6				●															
	APKT160408-PM	17.877	9.33	5.76	4.4	0.8	●	●	●	●	●	●	●	●	●	●	●	●	●	●	●	●	●	●	●
	APKT11T304-PR	12.24	6.5	3.6	2.8	0.4			●			○													
	APKT11T308-PR	12.24	6.5	3.6	2.8	0.4																			
	APKT11T312-PR	12.24	6.5	3.6	2.8	0.4																			
	APKT11T316-PR	12.24	6.5	3.6	2.8	0.4																			
	APKT160408-PR	17.877	9.33	5.76	4.4	0.8																			
	APKT11T304-LH	12.24	6.5	3.6	2.8	0.4																	●	●	
	APKT11T308-LH	12.24	6.5	3.6	2.8	0.8																	●	●	
	APKT160408-LH	17.877	9.33	5.76	4.4	0.8																	●	●	

B

Milling Tools / Fräser

Applicable tool / Werkzeug: B11-B18

Tools code key / Werkzeug ISO: B26-B27

Grade selection guide / Sortenauswahl: B19-B23

Technical data / Technische Daten: B215-B220

Milling · Fräsen

Indexable Milling Tools · Wendepplattenfräser

Chipbreaker Selection EMP01 · Spanbrecher Auswahl EMP01

Application Anwendung	Finishing Schlichten	Semi-Finishing Mittlere Bearbeitung	Roughing Schruppen
P	-PF	-PM	-PR
M	-PF	-PM	-PR
K	-PF	-PM	
AL	-LH		

- 1 Square shoulder milling
- 1 Eckfräsen

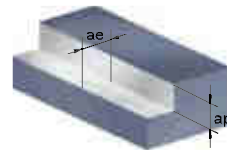

Recommended cutting data · Empfohlene Schnittdaten

Workpiece material Werkstück Material	Hardness HB Härte	Grade Sorte	Cutting data Schnittdaten				
			V(m/min)	f(mm/z)			ae(mm)
				-PF	-PM	-PR	
P	Low-carbon steel Soft steel Niedrig legierter Kohlenstoffstahl Baustahl	YBM251 YBC301	320 (240-400)	0.1 (0.08-0.2)	0.2 (0.1-0.3)	0.25(0.2-0.35)	≤0.5D
		YBM351	260 (180-380)	0.1 (0.08-0.2)	0.2 (0.1-0.3)	0.25(0.2-0.35)	≤0.5D
		YBG202 YBG205	320 (200-400)	0.1 (0.08-0.2)	0.2 (0.1-0.3)	0.25(0.2-0.35)	≤0.5D
		YBG302	280 (180-400)	0.1 (0.08-0.2)	0.2 (0.1-0.3)	0.25(0.2-0.35)	≤0.5D
	High-carbon steel Alloy steel Hoch Leg. Kohlenstoffstahl Leg. Stahl	YBM251 YBC301	280 (210-380)	0.1 (0.08-0.2)	0.2 (0.1-0.3)	0.25(0.2-0.3)	≤0.5D
		YBM351	240 (160-320)	0.1 (0.08-0.2)	0.2 (0.1-0.3)	0.25(0.2-0.35)	≤0.5D
		YBG202 YBG205	280 (180-350)	0.1 (0.08-0.2)	0.2 (0.1-0.3)	0.25(0.2-0.3)	≤0.5D
		YBG302	260 (150-380)	0.1 (0.08-0.2)	0.2 (0.1-0.3)	0.25(0.2-0.35)	≤0.5D
	Alloy tool steel Leg. Werkzeugstahl	YBM251 YBC301	260 (180-350)	0.1 (0.08-0.2)	0.2 (0.1-0.3)	0.25(0.2-0.3)	≤0.5D
		YBM351	220 (150-280)	0.1 (0.08-0.2)	0.2 (0.1-0.3)	0.25(0.2-0.35)	≤0.5D
		YBG202 YBG205	260 (160-330)	0.1 (0.08-0.2)	0.2 (0.1-0.3)	0.25(0.2-0.3)	≤0.5D
		YBG302	240 (120-350)	0.1 (0.08-0.2)	0.2 (0.1-0.3)	0.25(0.2-0.35)	≤0.5D
M	Stainless steel Rostfreier Stahl	YBM251	200 (120-270)	0.1 (0.08-0.2)	0.2 (0.1-0.3)	0.25(0.2-0.3)	≤0.5D
		YBM351	180 (150-300)	0.1 (0.08-0.2)	0.2 (0.1-0.3)	0.25(0.2-0.3)	≤0.5D
		YBG202 YBG205	200 (110-300)	0.1 (0.08-0.2)	0.2 (0.1-0.3)	0.25(0.2-0.3)	≤0.5D
		YBG302	170 (100-280)	0.1 (0.08-0.2)	0.2 (0.1-0.3)	0.25(0.2-0.3)	≤0.5D
K	Cast iron Gusseisen	YBG102	220 (120-250)	0.1 (0.08-0.2)	0.2 (0.1-0.3)	-	≤0.5D
		YBD152	240 (180-300)	-	0.2 (0.1-0.3)	-	≤0.5D
		YBD252	200 (120-320)	-	0.2 (0.1-0.3)	-	≤0.5D
N	Al alloy Al Leg.				-LH		
		YD101	300-	0.2 (0.08-0.4)		≤0.5D	
		YD201	300-	0.2 (0.08-0.4)		≤0.5D	

● Ex Stock / ab Lager ○ On demand / auf Anfrage

2 Slot milling 2 Nutenfräsen

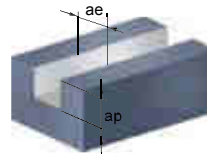

Recommended cutting data · Empfohlene Schnittdaten

Workpiece material Werkstück Material	Hardness HB Härte	Grade Sorte	Cutting data Schnittdaten				
			V(m/min)	f(mm/z)			ae(mm)
				-PF	-PM	-PR	
P	Low-carbon steel Soft steel Niedrig legierter Kohlenstoffstahl Baustahl	YBM251 YBC301	190 (170-250)	0.1 (0.08-0.15)	0.15 (0.1-0.25)	0.2 (0.2-0.3)	D
		YBM351	150 (130-210)	0.1 (0.08-0.15)	0.15 (0.1-0.25)	0.2 (0.2-0.3)	D
		YBG202 YBG205	190 (140-250)	0.1 (0.08-0.15)	0.15 (0.1-0.25)	0.2 (0.2-0.3)	D
		YBG302	170 (130-250)	0.1 (0.08-0.15)	0.15 (0.1-0.25)	0.2 (0.2-0.3)	D
	High-carbon steel Alloy steel Hoch Leg. Kohlenstoffstahl Leg. Stahl	YBM251 YBC301	170 (150-220)	0.1 (0.08-0.15)	0.15 (0.1-0.25)	0.2 (0.2-0.3)	D
		YBM351	140 (110-200)	0.1 (0.08-0.15)	0.15 (0.1-0.25)	0.2 (0.2-0.3)	D
		YBG202 YBG205	170 (130-250)	0.1 (0.08-0.15)	0.15 (0.1-0.25)	0.2 (0.2-0.3)	D
		YBG302	150 (110-230)	0.1 (0.08-0.15)	0.15 (0.1-0.25)	0.2 (0.2-0.3)	D
	Alloy tool steel Leg. Werkzeugstahl	YBM251 YBC301	150 (130-210)	0.1 (0.08-0.15)	0.15 (0.1-0.25)	0.2 (0.2-0.3)	D
		YBM351	130 (100-180)	0.1 (0.08-0.15)	0.15 (0.1-0.25)	0.2 (0.2-0.3)	D
		YBG202 YBG205	150 (110-240)	0.1 (0.08-0.15)	0.15 (0.1-0.25)	0.2 (0.2-0.3)	D
		YBG302	140 (80-210)	0.1 (0.08-0.15)	0.15 (0.1-0.25)	0.2 (0.2-0.3)	D
M	Stainless steel Rostfreier Stahl	YBM251	110 (80-190)	0.1 (0.08-0.15)	0.15 (0.1-0.25)	0.2 (0.2-0.3)	D
		YBM351	100 (80-170)	0.1 (0.08-0.15)	0.15 (0.1-0.25)	0.2 (0.2-0.3)	D
		YBG202 YBG205	120 (80-190)	0.1 (0.08-0.15)	0.15 (0.1-0.25)	0.2 (0.2-0.3)	D
		YBG302	100 (70-180)	0.1 (0.08-0.15)	0.15 (0.1-0.25)	0.2 (0.2-0.3)	D
K	Cast iron Gusseisen	YBG102	130 (80-180)	0.1 (0.08-0.15)	0.15 (0.1-0.25)	-	D
		YBD152	140 (80-210)	-	0.15 (0.1-0.25)	-	D
		YBD252	120 (80-210)	-	0.15 (0.1-0.25)	-	D
N	Al alloy Al Leg.	YD101	300-	-LH			D
		YD201	300-	0.2 (0.08-0.3)			D

Milling · Fräsen

Indexable Milling Tools · Wendeplattenfräser

3 Ramp milling, helical interpolation milling
3 Tauchfräsen, Spiral Interpolationsfräsen

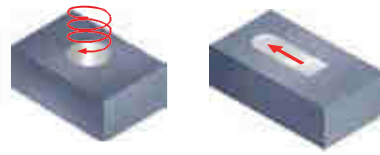

Recommended cutting data · Empfohlene Schnittdaten

B

Milling Tools
Fräser

● Ramp milling Tauchfräsen

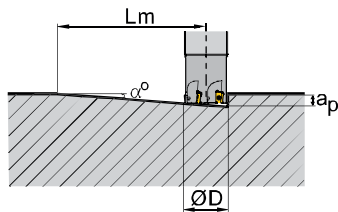

$$L_m = \frac{a_p}{\tan \alpha} \quad \begin{matrix} (\alpha: \text{Maximum ramp angle}) \\ (\alpha: \text{Maximaler Eintauchwinkel}) \end{matrix}$$

● Helical interpolation milling Spiral-Interpolationsfräsen

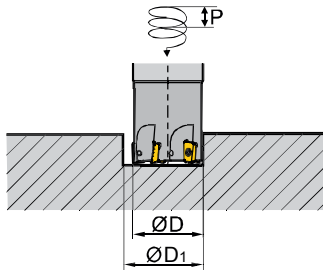

$$\tan \alpha = \frac{P}{\pi D_1} \quad \begin{matrix} (\alpha: \text{helical angle}) \\ (\alpha: \text{Spiral Winkel}) \end{matrix}$$

Diameter Durchmesser Ø D (mm)	APKT Ramp milling, helical interpolation milling (Inserts—11) APKT Tauchfräsen, Spiral-Interpolationsfräsen				
	Ramp milling Tauchfräsen			Helical interpolation milling Spiral-Interpolationsfräsen	
	Max. cutting depth Schnitttiefe $a_p(\text{mm})$	Max. ramp angle Eintauchwinkel α°	Min. length Länge $L_m(\text{mm})$	Min. diameter Durchmesser $\text{Ø } D_1(\text{mm})$	Max. pitch Steigung (mm)
16	10.0	10.0	56.7	20.0	2.0
20	10.0	5.0	114.4	28.0	2.0
25	10.0	4.5	127.0	40.0	2.0
32	10.0	3.0	190.8	56.0	2.0
40	10.0	2.0	286.4	70.0	2.0

● Ex Stock / ab Lager ○ On demand / auf Anfrage

QCH - RD

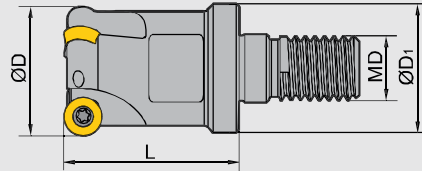

Type Typ	Stock Lager	Dimensions (mm) Abmessungen				Insert WSP	No. of teeth Zähne (Z)	Weight Gewicht (kg)	Coolant Kühlung	
		ØD	ØD ₁	L	MD					
QCH	-16-RDKW0702-M8-02	●	16	15	25	8	RDKW0702MO	2	0.027	-
	-16-RDKW0702-M8-03	●	16	15	25	8		3	0.030	
	-20-RDKW0702-M10-03	●	20	19	30	10		3	0.058	
	-25-RDKW0702-M12-03	●	25	24	35	12		3	0.093	
	-20-RDKW10T3-M10-02	●	20	19	30	10	RDKW10T3MO	2	0.054	
	-25-RDKW10T3-M12-02	●	25	24	35	12		2	0.097	
	-32-RDKW10T3-M16-03	●	32	30	45	16		3	0.183	
	-32-RDKW1605-M16-02	●	32	30	45	16		RDKW1605MO	2	
-15-RDKW0702-M8-02	○	15	12.5	23	8	RDKW0702MO	2	-	Internal cooling Innen Kühlung	
-15-RDKW0702-M8-03	○	15	12.5	23	8		3	-		
-20-RDKW0702-M10-04	○	20	18	30	10		4	-		
-25-RDKW0702-M12-05	○	25	21	35	12		5	-		
-20-RDKW1003-M10-02	○	20	18	30	10	RDKW1003MO	2	-		
-25-RDKW1003-M12-02	○	25	21	35	12		2	-		
-25-RDKW1003-M12-03	○	25	21	35	12		3	-		
-30-RDKW1003-M16-04	○	30	29	43	16		4	-		
-35-RDKW1003-M16-04	○	35	29	43	16	RDKW12T3MO	4	-		
-42-RDKW1003-M16-05	○	42	29	43	16		5	-		
-24-RDKW12T3-M12-02	○	24	21	35	12		2	-		
-35-RDKW12T3-M16-03	○	35	29	43	16	RDKW12T3MO	3	-		
-42-RDKW12T3-M16-04	○	42	29	43	16		4	-		
-32-RDKW1604-M16-02	○	32	29	43	16	RDKW1604MO	2	-		

Spare parts · Ersatzteile

Insert Durchmesser Ø D	Insert Screw Schraube	Wrench Schlüssel	
RDKW0702MO	I60M2.5×5	WT07IP	--
RDKW10T3MO	I60M4×8	WT15IP	--
RDKW1003MO	I60M3.5×7.7	WT15	--
RDKW12T3MO	I60M3.5×7.7	WT15	--
RDKW1604MO	I60M4.5×10	WT20	--
RDKW1605MO	I60M5×13	--	WT20IT



Applicable tool B11-B18
Werkzeug

Tools code key B26-B27
Werkzeug ISO

Grade selection guide B19-B23
Sortenauswahl

Technical data B215-B220
Technische Daten

Milling - Fräsen

Indexable Milling Tools - Wendepplattenfräser

Applicable inserts - Wendeschneidplatten

● Ideal Machining Condition / Gute Bearbeitungsbedingungen
● Normal Machining Condition / Normale Bearbeitungsbedingungen
● Unfavorable Machining Condition / Ungünstige Bearbeitungsbedingungen

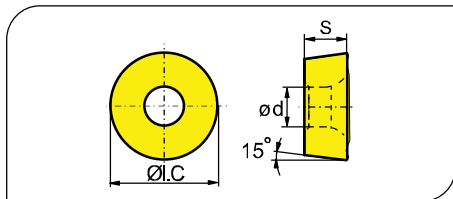

Workpiece Material / Werkstoffe	P	M	K	N	S
Steel / Stahl	●●●●●●●●●●	●●●●●●●●●●	●●●●●●●●●●	●●●●●●●●●●	●●●●●●●●●●
Stainless Steel / Rostfreier Stahl	●●●●●●●●●●	●●●●●●●●●●	●●●●●●●●●●	●●●●●●●●●●	●●●●●●●●●●
Cast iron / Gusseisen	●●●●●●●●●●	●●●●●●●●●●	●●●●●●●●●●	●●●●●●●●●●	●●●●●●●●●●
Non-ferrous material / Ne Metalle	●●●●●●●●●●	●●●●●●●●●●	●●●●●●●●●●	●●●●●●●●●●	●●●●●●●●●●
Heat-resistant steel / Warmfester Stahl	●●●●●●●●●●	●●●●●●●●●●	●●●●●●●●●●	●●●●●●●●●●	●●●●●●●●●●

Insert shape / Plattenform	Type / Typ	Dimension (mm) / Abmessung			CVD Coating / CVD Beschicht.				PVD Coating / PVD Beschicht.				Cement / Cemet	Carbide uncoat. / unbe. Hartmetall										
		I.C	S	d	YBC301	YBC302	YBC401	YBM251	YBM253	YBM351	YBD152	YBD252	YBG102	YBG202	YBG205	YBG302	YBG152	YBG252	YNG151	YNG151C	YC30S	YD101	YD201	
	RDKW0702MO	7.0	2.38	2.7					●			●	●											
	RDKW0803MO	8.0	3.18	3.4					●				●											
	RDKW1003MO	10.0	3.18	3.9				●	●				●	●										
	RDKW10T3MO	10.0	3.97	4.4	○	●			●				●	●										
	RDKW1204MO	12.0	4.76	4.4	○	●		●	●				●	●	●	○								
	RDKW12T3MO	12.0	3.97	3.9			○	●	●				●	●									○	
	RDKW1604MO	16.0	4.76	5.2					●				●	●										
	RDKW1605MO	16.0	5.56	5.5					●				●	●	●									
RDKW2006MO	20.0	6.35	6.5	●				●			○													

Recommended cutting data - Empfohlene Schnittdaten

Workpiece material / Werkstück Material	Hardness HB / Härte	Grade / Sorte	V(m/min)	f(mm/z)	a _{max} (mm)							
					RDKW07**		RDKW10**		RDKW12**		RDKW16**	
					a _z	a _p	a _z	a _p	a _z	a _p	a _z	a _p
P Low-carbon steel / Soft steel / Niedrig legierter Kohlenstoffstahl / Baustahl	≤180	YBM351	220 (180-300)	0.25 (0.15-0.3)	1.6	3.5	2.3	5	3.3	6	3.9	8
		YBG302										
	180-280	YBM351	200 (160-280)	0.25 (0.15-0.3)	1.6	3.5	2.3	5	3.3	6	3.9	8
		YBG202										
280-350	Alloy tool steel / Leg. Stahl	YBM351	180 (150-250)	0.25 (0.15-0.3)	1.6	3.5	2.3	5	3.3	6	3.9	8
		YBG202										
M	Stainless steel / Rostfreier Stahl	YBM351	150 (100-220)	0.25 (0.1~0.3)	1.6	3.5	2.3	5	3.3	6	3.9	8
		YBG302										
K	Cast iron / Gusseisen	YBM351	210 (120-300)	0.2 (0.1-0.3)	1.6	3.5	2.3	5	3.3	6	3.9	8
		YBG202										

● Ex Stock / ab Lager ○ On demand / auf Anfrage

QCH - ZOHX

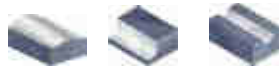

P M K N S

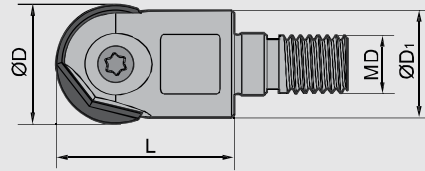

Type Typ	Stock Lager	Dimensions (mm) Abmessungen				Insert WSP	Weight Gewicht (kg)
		ØD	ØD ₁	L	MD		
QCH							
-16-ZOHX16-M8	●	16	15	28	8	ZOHX1604-**	0.029
-20-ZOHX20-M10	●	20	19	30	10	ZOHX2005-**	0.048
-25-ZOHX25-M12	●	25	24	35	12	ZOHX2506-**	0.087
-30-ZOHX30-M16	●	30	29	45	16	ZOHX3007-**	0.170
-32-ZOHX32-M16	●	32	30	45	16	ZOHX3207-**	0.180

B

Milling Tools
Fräser

■ Spare parts · Ersatzteile

Diameter Durchmesser Ø D	Insert Screw Schraube	Wrench Schlüssel	
Ø16	I70M5×12TT	WT20IP	--
Ø20	I70M5×16TT	WT20IP	--
Ø25	I70M6×20TT	WT20IP	--
Ø30	I70M8×25TT	--	WT30IT
Ø32	I70M8×25TT	--	WT30IT



Applicable tool **B11-B18**
Werkzeug

Tools code key **B26-B27**
Werkzeug ISO

Grade selection guide **B19-B23**
Sortenauswahl

Technical data **B215-B220**
Technische Daten

Hard alloy toolholder · Hartmetal Verlängerung

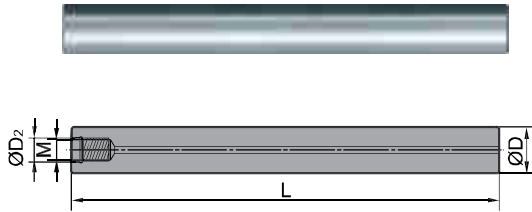

Fig 1

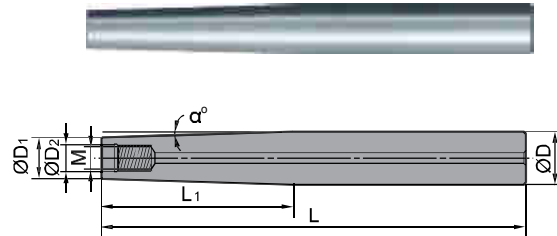

Fig 2

Type Typ	Stock Large	Flg	Dimensions (mm) Abmessungen						
			L	M	ØD ₂	ØD	ØD ₁	L ₁	α°
G16-QCH-M8-100C	○	1	100	M8	8.5	16	--	--	--
G16-QCH-M8-150C	○		150			16	--	--	--
G20-QCH-M8-200C-ZJ90	○	2	200			20	15.5	90	1.3°
G20-QCH-M8-250C-ZJ115	○		250			20	15.5	115	1°
G20-QCH-M8-300C-ZJ135	○		300			20	15.5	135	0.85°
G20-QCH-M10-100C	○	1	100			M10	10.5	20	--
G20-QCH-M10-150C	○		150	20	--			--	--
G20-QCH-M10-200C	○	2	200	20	20			--	--
G25-QCH-M10-200C-ZJ90	○		200	25	19.8			90	1.6°
G25-QCH-M10-250C-ZJ115	○		250	25	19.8			115	1.25°
G25-QCH-M10-300C-ZJ135	○	300	25	19.8	135			1.1°	
G25-QCH-M12-100C	○	1	100	M12	12.5	25	--	--	--
G25-QCH-M12-150C	○		150			25	--	--	--
G25-QCH-M12-200C	○	2	200			25	--	--	--
G25-QCH-M12-200C-ZJ90	○		200			32	24.5	90	2.3°
G25-QCH-M12-250C-ZJ115	○		250			32	24.5	115	1.75°
G25-QCH-M12-300C-ZJ135	○	300	32			24.5	135	1.5°	
G32-QCH-M16-150C	○	1	150	M16	17	32	--	--	--
G32-QCH-M16-200C	○		200			32	--	--	--
G32-QCH-M16-250C	○	2	250			32	--	--	--
G32-QCH-M16-300C	○		300			32	--	--	--
G32-QCH-M16-200C-ZJ90	○		200			32	30	90	0.64°
G32-QCH-M16-250C-ZJ115	○	250	32			30	115	0.5°	
G32-QCH-M16-300C-ZJ135	○	300	32	30	135	0.4°			

Applicable tool B11-B18
Werkzeug

Tools code key B26-B27
Werkzeug ISO

Grade selection guide B19-B23
Sortenauswahl

Technical data B215-B220
Technische Daten

Milling · Fräsen

Indexable Milling Tools · Wendeplattenfräser

Steel toolholder · Stahl Verlängerung

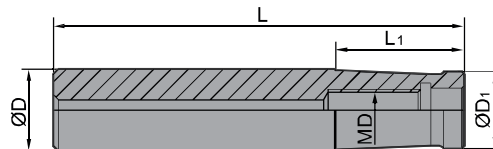

Type Typ	Stock Large	Dimensions (mm) Abmessungen				
		ØD	L	L ₁	ØD ₁	MD
G16-QCH-M8-80	○	16	80	25	15	M8
G16-QCH-M8-100	○	16	100	45	15	M8
G20-QCH-M10-90	○	20	90	35	18.5	M10
G20-QCH-M10-105	○	20	105	50	18.5	M10
G25-QCH-M12-90	○	25	90	30	24	M12
G25-QCH-M12-110	○	25	110	50	24	M12
G32-QCH-M16-100	○	32	100	35	28.5	M16
G32-QCH-M16-120	○	32	120	55	28.5	M16
G32-QCH-M16-115	○	32	115	40	30	M16
G32-QCH-M16-135	○	32	135	60	30	M16



● Ex Stock / ab Lager ○ On demand / auf Anfrage



Milling · Fräsen







Indexable Milling Tools · Wendeplattenfräser









Inserts - face milling · WSP - Planfräsen

							
SEET-CF	SEET-CM	SEET-CR	SEET-DF	SEET-DM	SEET-DR	SEET-EF	SEET-EM
Page Seite	B199	B199	B199	B199	B199	B199	B199

							
SEET-LH	SEET-W	SEKN/SEEN	SEKR	OFKT-DF	OFKT-DM	OFKT-LH	OFKR-DF / DM
Page Seite	B199	B199	B201	B201	B192	B192	B192







							
OFKR-LH	ONHU-PF	ONHU-PM	ONHU-W	SNEG-GM/GR	HNEX-DF	HNEX-DM	HNEX-DR
Page Seite	B192	B193	B193	B202	B189	B189	B189

								
PNEG-CF/CM/CR	PNEG-PF/PM/PR	LNKT-ZR	LNE32.534 / 32.302	LNCX	SPKW	SPKT	SPAN/SPCN	SPKN
Page Seite	B194	B194	B190	B190	B191	B205	B207	B203





							
SPKR-GM	SPEX	SPMR	SPGN/SPUN	TPAN/TPCN	TPKN	TPUN	TPMR
Page Seite	B205	B206	B207	B208	B209	B210	B211

							
SEET*PER-PF	SEET*PER-PM	SEET*PER-PR	SEET-LH	RCKT-DM	RCKT-DR	RCKT-ER	RDKW
Page Seite	B200	B200	B200	B200	B197	B197	B197



Inserts - square shoulder milling · WSP - Eckfräsen

					
APKT-PF	APKT-PM	APKT-PR	APKT-LH	APMT-PDR	APMT-PDER
Page Seite	B186	B186	B186	B187	B187





Inserts for profile milling · WSP - Formfräsen

							
ZDET	ZPNT	SPMT	ROHX	XPHT-GM	ZOHX-GF	ZOHX-GM	
Page Seite	B213	B214	B207	B198	B212	B214	B214

Inserts - side and face milling WSP - Seiten- und Stirnfräsen

			
XSEQ	MPHT	QC**L	
Page Seite	B213	B191	B195 / 196



Inserts - high feed milling WSP - Hochvorschubfräsen

					
SDMT	SDMT-DM	SDMT-PM	WPGT	WPGT-PM	
Page Seite	B198	B198	B199	B212	B212

Inserts - T-slot milling WSP - T-Nuten - Fräsen

	
MPHT	
Page Seite	B191



Inserts - helical milling WSP - Zirkularfräsen

		
APKT-PM/KM	SPMT-PM/KM	
Page Seite	B188	B207

Inserts - chamfer milling WSP - Fasenfräsen

	
SPMT SPMT-KT SPMT-HT	
Page Seite	B207











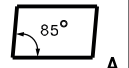
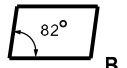
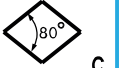
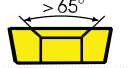



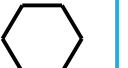
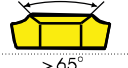

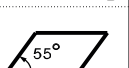
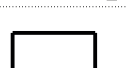

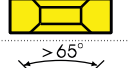
Inserts - face milling - square shoulder milling WSP - Planfräsen - Eckfräsen

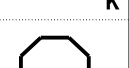
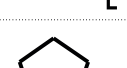
		
CNE-A	CNE-B	
Page Seite	B188	B188

Milling - Fräsen

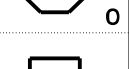
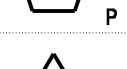

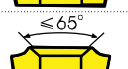

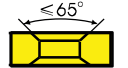
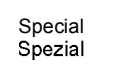
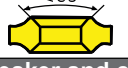
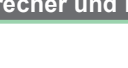



Indexable Milling Tools - Wendepplattenfräser

Indexable milling inserts code key - Wendepplattenfräser ISO Kode

Insert Code · WSP Code			Metric System · Metrisches System				
Code	Hole Loch	Chipbreaker Spanbrecher	Section Form	Code	Hole Loch	Chipbreaker Spanbrecher	Section Form
 A	 B	 C		N	-	-	
 D	 E	 H		R	-	Single-side Einseitig	
 K	 L	 M		F	-	Double-side Doppelseitig	
 O	 P	 R		A	✓	-	
 S	 T	 V		M	✓	Single-side Einseitig	
 W	Others Ander Z			G	✓	Double-side Doppelseitig	
				X	---	---	Special Spezial
				U	✓	Double-side Doppelseitig	

Insert · WSP **Chipbreaker and clamping system Spanbrecher und Klemmsystem**

S P K N

Clearance angle of main cutting edge Freiwinkel der Hauptschneid			
Code	Clearance angle Freiwinkel	Code	Clearance angle Freiwinkel
A	 3°	B	 5°
C	 7°	D	 15°
E	 20°	F	 25°
G	 30°	N	 0°
P	 11°	O	Other clearance angle Andere Freiwinkel

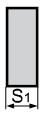
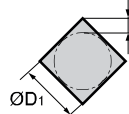
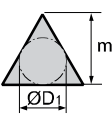
Tolerance · Toleranz												
												
Code	Nose height Toleranzhöhe (mm)	M	Inscribed circle Ø D ₁ Tolerance Toleranzinnenkreis Ø D ₁ (mm)	Thickness Toleranz Dicke S (mm)	S	Reference details of M-class tolerance (identified by shape and size) Referenz Detail Toleranz M-Klasse (definiert durch Form und Größe)						
						● Nose height tolerance (mm) / Toleranz M						
						Inscribed circle Innenkreis	Regular Dreieckig	Square Viereckig	Diamond with 80° Raute mit 80°	Diamond with 55° Raute mit 55°	Diamond with 35° Raute mit 35°	Round Rund
A	±0.005		±0.025	±0.025		6.35	±0.08	±0.08	±0.08	±0.11	±0.16	---
F	±0.005		±0.013	±0.025		9.525	±0.08	±0.08	±0.08	±0.11	±0.16	---
C	±0.013		±0.025	±0.025		12.7	±0.13	±0.13	±0.13	±0.15	---	---
H	±0.013		±0.013	±0.025		15.875	±0.15	±0.15	±0.15	±0.18	---	---
E	±0.025		±0.025	±0.025		19.05	±0.15	±0.15	±0.15	±0.18	---	---
G	±0.025		±0.025	±0.13		25.4	---	±0.18	---	---	---	---
J	±0.005		±0.05 - ±0.13	±0.025		● Tolerance of Inscribed Circle ØD ₁ (mm) / Toleranzinnenkreis ØD ₁						
K	±0.013		±0.05 - ±0.13	±0.025		Inscribed circle Innenkreis	Regular Dreieckig	Square Viereckig	Diamond with 80° Raute mit 80°	Diamond with 55° Raute mit 55°	Diamond with 35° Raute mit 35°	Round Rund
L	±0.025		±0.05 - ±0.13	±0.025		6.35	±0.05	±0.05	±0.05	±0.05	±0.05	---
M	±0.08 - ±0.18		±0.05 - ±0.13	±0.13		9.525	±0.05	±0.05	±0.05	±0.05	±0.05	±0.05
N	±0.08 - ±0.18		±0.05 - ±0.13	±0.025		12.7	±0.08	±0.08	±0.08	±0.08	---	±0.58
U	±0.13 - ±0.38		±0.08 - ±0.25	±0.13		15.875	±0.10	±0.10	±0.10	±0.10	---	±0.10
						19.05	±0.10	±0.10	±0.10	±0.10	---	±0.10
						25.4	---	±0.13	---	---	---	±0.13

Milling Tools
Fräser

Diameter of IC Durchmesser von IC	Insert / WSP						
	C	D	R	S	T	V	W
3.97					06		
5.0			05				
5.56					09		
6.0			06				
6.35	06	07			11	11	
8.0			08				
9.525	09	11	09	09	16	16	06
10.0			10				
12.0			12				
12.7	12	15	12	12	22	22	08
15.875	16		15	15	27		
16.0		19	16				
19.05	19		19	19	33		
20.0			20				
25.0	25	25	25	25			
25.4			25	25			
31.75			31				
32			32				

Length of cutting edge · Schneidkantenlänge









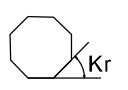
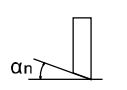





Code	Insert thickness (mm) Plattendicke
00	0.79
T0	0.99
01	1.59
T1	1.98
02	2.38
T2	2.58
03	3.18
T3	3.97
04	4.76
T4	4.96
05	5.96
T5	5.95
06	6.35
T6	6.75
07	7.94
09	9.52
T9	9.72
11	11.11
12	12.70

Insert thickness · WSP Dicke

12 04 ED T21K R-DM

Angel · Winkel			
			
A	45°	A	3°
D	60°	B	5°
E	75°	C	7°
F	85°	D	15°
P	90°	E	20°
Z	Others Andere	F	25°
		G	30°
		N	0°
		P	11°
		Z	Others Andere

Chamfer · Fase (mm)			
F			
	0-5°	0-0.10	K
E			
	1-10°	1-0.15	P
T			
	2-15°	2-0.20	W
	3-20°	3-0.25	
S			
	4-25°	4-0.30	No mark
	5-30°	5-0.35	
		6-0.40	
		7-0.45	

Chipbreaker code
Spanbrecher

Cutting direction Schnitttrichtung	
R	Right hand Rechts
L	Left hand Links
N	Neutral Neutral

Milling · Fräsen

Indexable Milling Tools · Wendepplattenfräser

AP**

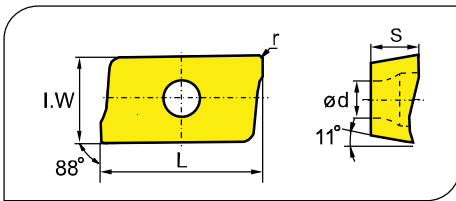

- Ideal Machining Condition / Gute Bearbeitungsbedingungen
- Normal Machining Condition / Normale Bearbeitungsbedingungen
- Unfavorable Machining Condition / Ungünstige Bearbeitungsbedingungen

Workpiece Material / Werkstoffe	P	M	K	N	S
P Steel / Stahl	●	●	●	●	●
M Stainless Steel / Rostfreier Stahl	●	●	●	●	●
K Cast iron / Gusseisen	●	●	●	●	●
N Non-ferrous material / Ne Metalle	●	●	●	●	●
S Heat-resistant steel / Warmfester Stahl	●	●	●	●	●

Insert shape / Plattenform	Type / Typ	Dimensions (mm) / Abmessungen					CVD Coating / CVD Beschicht.						PVD Coating / PVD Beschicht.					Cermets / Cermet	Carbide uncoat. / unbe. Hartmetall							
		L	I.W	S	d	r	YBC301	YBC302	YBC401	YBM251	YBM253	YBM351	YBD152	YBD252	YBG102	YBG202	YBG205		YBG302	YBG152	YBG252	YNG151	YNG151C	YC30S	YD101	YD201
	APKT11T304-PF	12.24	6.5	3.6	2.8	0.4	○		●						●	●		●								
	APKT11T308-PF	12.24	6.5	3.6	2.8	0.8			○							●										
	APKT11T312-PF	12.24	6.5	3.6	2.8	1.2										○										
	APKT11T316-PF	12.24	6.5	3.6	2.8	1.6										○										
	APKT160408-PF	17.877	9.33	5.76	4.4	0.8	●			○	●					●		●								
	APKT11T304-PM	12.24	6.5	3.6	2.8	0.4	●	●	●	●	●				●	●		●								
	APKT11T308-PM	12.24	6.5	3.6	2.8	0.8	●	●		●	●	●	●	●	●	●	●	●								
	APKT11T312-PM	12.24	6.5	3.6	2.8	1.2				○						○	●									
	APKT11T316-PM	12.24	6.5	3.6	2.8	1.6				●						○	●									
	APKT160408-PM	17.877	9.33	5.76	4.4	0.8	●	●	●	●	●	●	●	●	●	●	●	●	●							
	APKT11T304-PR	12.24	6.5	3.6	2.8	0.4			●			○						○								
	APKT11T308-PR	12.24	6.5	3.6	2.8	0.8												○								
	APKT11T312-PR	12.24	6.5	3.6	2.8	1.2												○								
	APKT11T316-PR	12.24	6.5	3.6	2.8	1.6												○								
	APKT160408-PR	17.877	9.33	5.76	4.4	0.8												○								
	APKT11T304-LH	12.24	6.5	3.6	2.8	0.4																		●	●	
	APKT11T308-LH	12.24	6.5	3.6	2.8	0.8																		●	●	
	APET160402-LH	17.877	9.33	5.76	4.4	0.2																		○		
	APKT160408-LH	17.877	9.33	5.76	4.4	0.8																		●	●	
	APET160408PDFR-LH	17.877	9.33	5.76	4.4	0.8																		○		

● Ex Stock / ab Lager ○ On demand / auf Anfrage

Milling Tools / Fräser

AP**

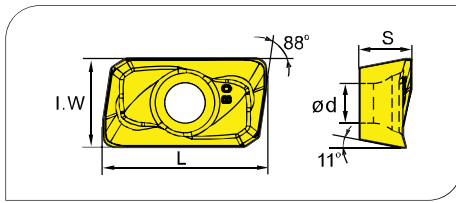

- Ideal Machining Condition / Gute Bearbeitungsbedingungen
- Normal Machining Condition / Normale Bearbeitungsbedingungen
- Unfavorable Machining Condition / Ungünstige Bearbeitungsbedingungen

Workpiece Material / Werkstoffe	P	M	K	N	S	YBC301	YBC302	YBC401	YBM251	YBM253	YBM351	YBD152	YBD252	YBG102	YBG202	YBG205	YBG302	YBG152	YBG252	YNG151	YNG151C	YC30S	YD101	YD201
P Steel / Stahl	●	●	●	●	●																			
M Stainless Steel / Rostfreier Stahl		●	●	●	●																			
K Cast iron / Gusseisen																								
N Non-ferrous material / Ne Metalle																								
S Heat-resistant steel / Warmfester Stahl																								

Insert WSP	Type Typ	Dimensions (mm) / Abmessungen					CVD Coating / CVD Beschicht.						PVD Coating / PVD Beschicht.				Cermet / Cermet	Carbide uncoat / unbe. Hartmetall							
		L	I.W	S	d	r	YBC301	YBC302	YBC401	YBM251	YBM253	YBM351	YBD152	YBD252	YBG102	YBG202	YBG205	YBG302	YBG152	YBG252	YNG151	YNG151C	YC30S	YD101	YD201
	APMT1135PDR	11.25	6.2	3.5	2.8	0.8			○						○	○	●								
	APMT160408PDER	17.25	9.25	4.76	4.4	0.8			○		○				○	●									
	APMT160432PDER	17.25	9.25	4.76	4.4	3.2					○				●										

B

Milling Tools
Fräser

Applicable tool / Werkzeug **B11-B18**

Tools code key / WSP ISO **B184-B185**

Grade selection guide / Sortenauswahl **B19-B23**

Technical data / Technische Daten **B215-B220**

Milling - Fräsen

Indexable Milling Tools - Wendepplattenfräser

AP**

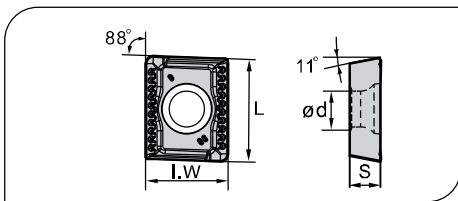

- Ideal Machining Condition / Gute Bearbeitungsbedingungen
- ⊕ Normal Machining Condition / Normale Bearbeitungsbedingungen
- ⊗ Unfavorable Machining Condition / Ungünstige Bearbeitungsbedingungen

Workpiece Material / Werkstoffe	P	M	K	N	S
Steel / Stahl	●	●	●	●	●
Stainless Steel / Rostfreier Stahl	●	⊕	⊕	⊕	⊕
Cast iron / Gusseisen	●	●	●	●	●
Non-ferrite material / Ne Metalle	●	●	●	●	●
Heat-resistant steel / Warmfester Stahl	●	●	●	●	●

Insert WSP	Type Typ	Dimensions (mm) / Abmessungen					CVD Coating / CVD Beschicht.				PVD Coating / PVD Beschicht.			Cermet / Cermet	Carbide uncoat. / unbe. Hartmetall												
		L	I.W	S	d	r	YBC301	YBC302	YBC401	YBM251	YBM253	YBM351	YBD152		YBD252	YBG102	YBG202	YBG205	YBG302	YBG152	YBG252	YNG151	YNG151C	YC30S	YD101	YD201	
	APKT150412-PM	16.33	12.7	4.76	5.4	1.2				●								●									
	APKT150412-KM	16.33	12.7	4.76	5.4	1.2												○	●								

CN

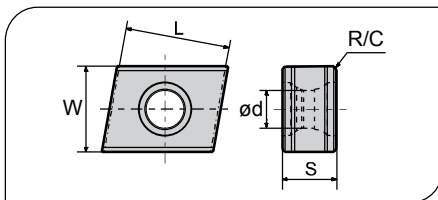

- Ideal Machining Condition / Gute Bearbeitungsbedingungen
- ⊕ Normal Machining Condition / Normale Bearbeitungsbedingungen
- ⊗ Unfavorable Machining Condition / Ungünstige Bearbeitungsbedingungen

Workpiece Material / Werkstoffe	P	M	K	N	S
Steel / Stahl	●	●	●	●	●
Stainless Steel / Rostfreier Stahl	●	⊕	⊕	⊕	⊕
Cast iron / Gusseisen	●	●	●	●	●
Non-ferrite material / Ne Metalle	●	●	●	●	●
Heat-resistant steel / Warmfester Stahl	●	●	●	●	●

Insert WSP	Type Typ	Dimensions (mm) / Abmessungen					CVD Coating / CVD Beschicht.				PVD Coating / PVD Beschicht.			Cermet / Cermet	Carbide uncoat. / unbe. Hartmetall												
		L	W	S	R/C	ød	YBC301	YBC302	YBC401	YBM251	YBM253	YBM351	YBD152		YBD252	YBG102	YBG202	YBG205	YBG302	YBG152	YBG252	YNG151	YNG151C	YC30S	YD101	YD201	
	CNE121006A	12.8	10.0	6.35	0.4	4.4				●		○															
	CNE121006B	12.0	10.0	6.35	0.6	4.4				○			●														

● Ex Stock / ab Lager ○ On demand / auf Anfrage

HN**

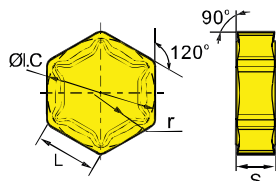

- Ideal Machining Condition / Gute Bearbeitungsbedingungen
- Normal Machining Condition / Normale Bearbeitungsbedingungen
- Unfavorable Machining Condition / Ungünstige Bearbeitungsbedingungen

Workpiece Material / Werkstoffe	P	M	K	N	S	YBC301	YBC302	YBC401	YBM251	YBM253	YBM351	YBD152	YBD252	YBG102	YBG202	YBG205	YBG302	YBG152	YBG252	YNG151	YNG151C	YC30S	YD101	YD201	
P Steel / Stahl	●	●	●	●	●	●	●	●	●	●	●	●	●	●	●	●	●	●	●	●	●	●	●	●	●
M Stainless Steel / Rostfreier Stahl		●	●	●	●				●	●	●				●	●	●		●	●					
K Cast iron / Gusseisen												●	●					●	●					●	
N Non-ferrous material / Ne Metalle																							●	●	
S Heat-resistant steel / Warmfester Stahl									●	●		●						●	●						

Insert WSP	Type Typ	Dimensions (mm) / Abmessungen				CVD Coating / CVD Beschicht.								PVD Coating / PVD Beschicht.				Cermets / Cermet		Carbide uncoat. / unbe. Hartmetall				
		L	I.C	S	R	YBC301	YBC302	YBC401	YBM251	YBM253	YBM351	YBD152	YBD252	YBG102	YBG202	YBG205	YBG302	YBG152	YBG252	YNG151	YNG151C	YC30S	YD101	YD201
	HNEX090512-DF	9.16	15.875	5.56	1.2							○												
	HNEX090512-DM	9.16	15.875	5.56	1.2							○												
	HNEX090512-DR	9.16	15.875	5.56	1.2						●	●												
	HNGX090516-MR	9.16	15.875	5.56	1.6						●													
	HNGX090520-MR	9.16	15.875	5.56	2.0						●							○						

B

Milling Tools
Fräser

Applicable tool / Werkzeug **B11-B18**

Tools code key / WSP ISO **B184-B185**

Grade selection guide / Sortenauswahl **B19-B23**

Technical data / Technische Daten **B215-B220**

Milling - Fräsen

Indexable Milling Tools - Wendepplattenfräser

LN**

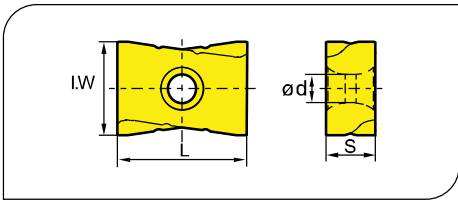

- Ideal Machining Condition / Gute Bearbeitungsbedingungen
- ⊗ Normal Machining Condition / Normale Bearbeitungsbedingungen
- ⊗ Unfavorable Machining Condition / Ungünstige Bearbeitungsbedingungen

Workpiece Material / Werkstoffe	P	M	K	N	S
Steel / Stahl	⊗	⊗	⊗	⊗	⊗
Stainless Steel / Rostfreier Stahl		⊗	⊗	⊗	⊗
Cast iron / Gusseisen			⊗	⊗	⊗
Non-ferrite material / Ne Metalle				⊗	⊗
Heat-resistant steel / Warmfester Stahl					⊗

Insert WSP	Type Typ	Dimensions (mm) / Abmessungen				CVD Coating / CVD Beschicht.				PVD Coating / PVD Beschicht.			Cermet / Cermet	Carbide uncoat. / unbe. Hartmetall												
		L	I.W	S	d	YBC301	YBC302	YBC401	YBM251	YBM253	YBM351	YBD152		YBD252	YBG102	YBG202	YBG205	YBG302	YBG152	YBG252	YNG151	YNG151C	YC30S	YD101	YD201	
	LNKT1506EN-ZR	15.875	14	6.35	4.6	●		●	●	●	●				●											
	LNKT2007DN-ZR	20	17	7.94	4.6						●					●										
	LNKT2510-ZR	25	18	9.525	5.5						●					●										

LN**

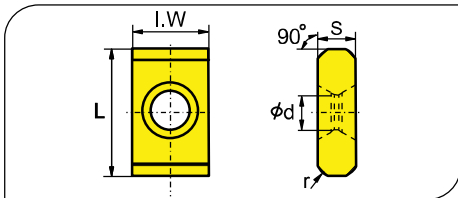

- Ideal Machining Condition / Gute Bearbeitungsbedingungen
- ⊗ Normal Machining Condition / Normale Bearbeitungsbedingungen
- ⊗ Unfavorable Machining Condition / Ungünstige Bearbeitungsbedingungen

Workpiece Material / Werkstoffe	P	M	K	N	S
Steel / Stahl	⊗	⊗	⊗	⊗	⊗
Stainless Steel / Rostfreier Stahl		⊗	⊗	⊗	⊗
Cast iron / Gusseisen			⊗	⊗	⊗
Non-ferrite material / Ne Metalle				⊗	⊗
Heat-resistant steel / Warmfester Stahl					⊗

Insert WSP	Type Typ	Dimensions (mm) / Abmessungen					CVD Coating / CVD Beschicht.				PVD Coating / PVD Beschicht.			Cermet / Cermet	Carbide uncoat. / unbe. Hartmetall												
		L	I.W	S	d	r	YBC301	YBC302	YBC401	YBM251	YBM253	YBM351	YBD152		YBD252	YBG102	YBG202	YBG205	YBG302	YBG152	YBG252	YNG151	YNG151C	YC30S	YD101	YD201	
	LNE32.534	15.875	9.525	4.76	4.4	1.6						●	○														
	LNE32.302	15.875	9.525	4.76	4.2	45 Fase				●				●													

● Ex Stock / ab Lager ○ On demand / auf Anfrage

LNCX

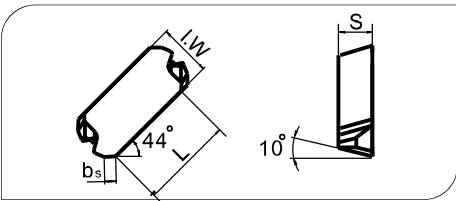

- Ideal Machining Condition / Gute Bearbeitungsbedingungen
- Normal Machining Condition / Normale Bearbeitungsbedingungen
- Unfavorable Machining Condition / Ungünstige Bearbeitungsbedingungen

Workpiece Material / Werkstoffe	P	M	K	N	S	YBC301	YBC302	YBC401	YBM251	YBM253	YBM351	YBD152	YBD252	YBG102	YBG202	YBG205	YBG302	YBG152	YBG252	YNG151	YNG151C	YC30S	YD101	YD201	
P Steel / Stahl	●					●	●	●	●	●	●	●	●	●	●	●	●	●	●	●	●	●			
M Stainless Steel / Rostfreier Stahl		●						●	●	●	●				●	●	●			●	●	●			
K Cast iron / Gusseisen			●						●	●	●	●	●						●	●					●
N Non-ferrite material / Ne Metalle				●																			●	●	
S Heat-resistant steel / Warmfester Stahl					●				●	●			●	●											

Insert WSP	Type Typ	Dimensions (mm) / Abmessungen				CVD Coating / CVD Beschicht.				PVD Coating / PVD Beschicht.				Cermet / Cermet	Carbide uncoat. / unbe. Hartmetall										
		L	I.W	S	bs	YBC301	YBC302	YBC401	YBM251	YBM253	YBM351	YBD152	YBD252		YBG102	YBG202	YBG205	YBG302	YBG152	YBG252	YNG151	YNG151C	YC30S	YD101	YD201
	LNCX1806AZR	18.77	10.0	6.4	2.0	●																			
	LNCX1806AZL	18.77	10.0	6.4	2.0																				

LNCX

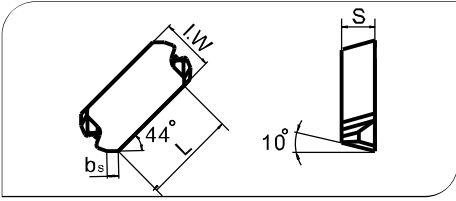

- Ideal Machining Condition / Gute Bearbeitungsbedingungen
- Normal Machining Condition / Normale Bearbeitungsbedingungen
- Unfavorable Machining Condition / Ungünstige Bearbeitungsbedingungen

Workpiece Material / Werkstoffe	P	M	K	N	S	YBC301	YBC302	YBC401	YBM251	YBM253	YBM351	YBD152	YBD252	YBG102	YBG202	YBG205	YBG302	YBG152	YBG252	YNG151	YNG151C	YC30S	YD101	YD201	
P Steel / Stahl	●					●	●	●	●	●	●	●	●	●	●	●	●	●	●	●	●	●			
M Stainless Steel / Rostfreier Stahl		●						●	●	●	●				●	●	●			●	●	●			
K Cast iron / Gusseisen			●						●	●	●	●	●						●	●					●
N Non-ferrite material / Ne Metalle				●																			●	●	
S Heat-resistant steel / Warmfester Stahl					●				●	●			●	●											

Insert WSP	Type Typ	Dimensions (mm) / Abmessungen					CVD Coating / CVD Beschicht.				PVD Coating / PVD Beschicht.				Cermet / Cermet	Carbide uncoat. / unbe. Hartmetall									
		L	I.W	S	bs	T-land	YBC301	YBC302	YBC401	YBM251	YBM253	YBM351	YBD152	YBD252		YBG102	YBG202	YBG205	YBG302	YBG152	YBG252	YNG151	YNG151C	YC30S	YD101
	LNCX1806AZT11R	18.77	10.0	6.4	2.0	0.1																			
	LNCX1806AZT11L	18.77	10.0	6.4	2.0	0.1																			

MP**

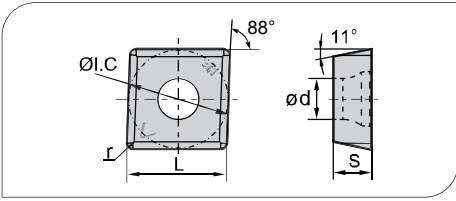

- Ideal Machining Condition / Gute Bearbeitungsbedingungen
- Normal Machining Condition / Normale Bearbeitungsbedingungen
- Unfavorable Machining Condition / Ungünstige Bearbeitungsbedingungen

Workpiece Material / Werkstoffe	P	M	K	N	S	YBC301	YBC302	YBC401	YBM251	YBM253	YBM351	YBD152	YBD252	YBG102	YBG202	YBG205	YBG302	YBG152	YBG252	YNG151	YNG151C	YC30S	YD101	YD201	
P Steel / Stahl	●					●	●	●	●	●	●	●	●	●	●	●	●	●	●	●	●	●			
M Stainless Steel / Rostfreier Stahl		●						●	●	●	●				●	●	●			●	●	●			
K Cast iron / Gusseisen			●						●	●	●	●	●						●	●					●
N Non-ferrite material / Ne Metalle				●																			●	●	
S Heat-resistant steel / Warmfester Stahl					●				●	●			●	●											

Insert WSP	Type Typ	Dimensions (mm) / Abmessungen					CVD Coating / CVD Beschicht.				PVD Coating / PVD Beschicht.				Cermet / Cermet	Carbide uncoat. / unbe. Hartmetall										
		I.C	L	S	d	r	YBC301	YBC302	YBC401	YBM251	YBM253	YBM351	YBD152	YBD252		YBG102	YBG202	YBG205	YBG302	YBG152	YBG252	YNG151	YNG151C	YC30S	YD101	YD201
	MPHT060304-DM	6.35	6.35	3.18	2.8	0.4	●			○																
	MPHT080305-DM	8.3	8.3	3.18	3.4	0.5	●			○																
	MPHT120408-DM	12.7	12.7	4.76	5.56	0.8	●			○																

Applicable tool / Werkzeug B11-B18

Tools code key / WSP ISO B184-B185

Grade selection guide / Sortenauswahl B19-B23

Technical data / Technische Daten B215-B220

Milling · Fräsen

Indexable Milling Tools · Wendepplattenfräser

OF**

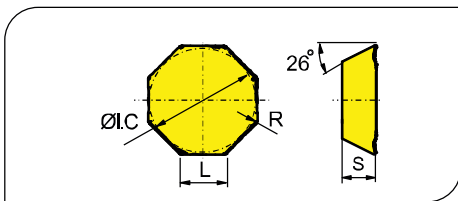

- Ideal Machining Condition / Gute Bearbeitungsbedingungen
- Normal Machining Condition / Normale Bearbeitungsbedingungen
- Unfavorable Machining Condition / Ungünstige Bearbeitungsbedingungen

Workpiece Material / Werkstoffe	P	M	K	N	S
Steel / Stahl	●	●	●	●	●
Stainless Steel / Rostfreier Stahl		●	●	●	●
Cast iron / Gusseisen			●	●	●
Non-ferrous material / Ne Metalle				●	●
Heat-resistant steel / Warmfester Stahl					●

Insert WSP	Type Typ	Dimensions (mm) / Abmessungen				CVD Coating / CVD Beschicht.				PVD Coating / PVD Beschicht.				Cermet / Cermet	Carbide uncoat. / unbe. Hartmetall											
		L	I.C	S	R	YBC301	YBC302	YBC401	YBM251	YBM253	YBM351	YBD152	YBD252		YBG102	YBG202	YBG205	YBG302	YBG152	YBG252	YNG151	YNG151C	YC30S	YD101	YD201	
	OFKR0704-DF	7.45	17.94	4.76	0.8				○						●											
	OFKR0704-DM	7.45	17.94	4.76	0.8	●	●	●		●	●	●	●	●	○	●										
	OFKR0704W-DM Lwiper	7.45	17.94	4.76		○						○			●	●										
	OFKR0704-LH	7.45	17.94	4.76																					○	

OF**

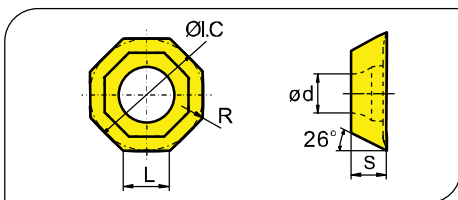

- Ideal Machining Condition / Gute Bearbeitungsbedingungen
- Normal Machining Condition / Normale Bearbeitungsbedingungen
- Unfavorable Machining Condition / Ungünstige Bearbeitungsbedingungen

Workpiece Material / Werkstoffe	P	M	K	N	S
Steel / Stahl	●	●	●	●	●
Stainless Steel / Rostfreier Stahl		●	●	●	●
Cast iron / Gusseisen			●	●	●
Non-ferrous material / Ne Metalle				●	●
Heat-resistant steel / Warmfester Stahl					●

Insert WSP	Type Typ	Dimensions (mm) / Abmessungen					CVD Coating / CVD Beschicht.				PVD Coating / PVD Beschicht.				Cermet / Cermet	Carbide uncoat. / unbe. Hartmetall											
		L	I.C	S	d	R	YBC301	YBC302	YBC401	YBM251	YBM253	YBM351	YBD152	YBD252		YBG102	YBG202	YBG205	YBG302	YBG152	YBG252	YNG151	YNG151C	YC30S	YD101	YD201	
	OFKT05T3-DF	5.26	12.7	3.97	4.4	0.5				○					●	●		○									
	OFKT05T3-DM	5.26	12.7	3.97	4.4	0.5				●		●			●	●	●										
	OFKT05T3-LH	5.26	12.7	3.97	4.4	0.5																			●		

● Ex Stock / ab Lager ○ On demand / auf Anfrage

ON**

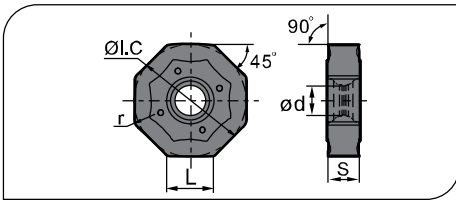

- Ideal Machining Condition / Gute Bearbeitungsbedingungen
- ⊕ Normal Machining Condition / Normale Bearbeitungsbedingungen
- ⊗ Unfavorable Machining Condition / Ungünstige Bearbeitungsbedingungen

Workpiece Material / Werkstoffe	P	M	K	N	S
Steel / Stahl	●	●	●	●	●
Stainless Steel / Rostfreier Stahl	●	⊗	⊗	⊗	⊗
Cast iron / Gusseisen	●	●	●	●	●
Non-ferrous material / Ne Metalle	●	●	●	●	●
Heat-resistant steel / Warmfester Stahl	●	●	●	●	●

Insert WSP	Type Typ	Dimensions (mm) / Abmessungen					CVD Coating / CVD Beschicht.						PVD Coating / PVD Beschicht.					Cermet / Cermet	Carbide uncoat. / unbe. Hartmetall							
		L	ØI.C	S	ød	r	YBC301	YBC302	YBC401	YBM251	YBM253	YBM351	YBD152	YBD252	YBG102	YBG202	YBG205		YBG302	YBG152	YBG252	YNG151	YNG151C	YC30S	YD101	YD201
	ONHU060408-PF	6.58	15.875	4.76	4.4	0.83	●					●			●											
	ONHU08T508-PF	8.37	20.2	5.77	5.3	0.83	●			●		○			●											
	ONHU060408-PM	6.58	15.875	4.76	4.4	0.83	●		●	●	●															
	ONHU08T508-PM	8.37	20.2	5.79	5.3	0.83	●			●	●	●														
	ONHU08T508-W	6.9	20.5	6.00	5.3	0.80						●		○												

B

Milling Tools / Fräser

Milling - Fräsen

Indexable Milling Tools - Wendepplattenfräser

PN**

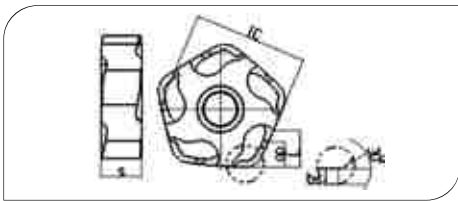

- Ideal Machining Condition / Gute Bearbeitungsbedingungen
- ⊗ Normal Machining Condition / Normale Bearbeitungsbedingungen
- ⊗ Unfavorable Machining Condition / Ungünstige Bearbeitungsbedingungen

Workpiece Material / Werkstoffe	Steel / Stahl		Stainless Steel / Rostfreier Stahl		Cast iron / Gusseisen		Non-ferrite material / Ne Metalle		Heat-resistant steel / Warmfester Stahl	
	P	M	K	N	S	P	M	K	N	S
P	●	●	●	●	●	●	●	●	●	●
M		●	●	●	●	●	●	●	●	●
K						●	●	●		●
N									●	●
S						●	●			

Insert WSP	Insert Typ	Dimension (mm) / Abmessung						CVD Coating / CVD Beschicht.					PVD Coating / PVD Beschicht.					Cermet / Cermet	Carbide uncoat. / unbe. Hartmetall									
		L	ØI.C	S	ød	bs	ap	YBC301	YBC302	YBC401	YBM251	YBM253	YBM351	YBD152	YBD252	YBG102	YBG202		YBG205	YBG302	YBG152	YBG252	YNG151	YNG151C	YC30S	YD101	YD201	
	PNEG110512R-CF	5.4	15.875	5.56	4.64	1.6	5							○														
	PNEG110512L-CF	5.4	15.875	5.56	4.64	1.6	5							○														
	PNEG110512R-CM	5.4	15.875	5.56	4.64	1.6	5							●														
	PNEG110512L-CM	5.4	15.875	5.56	4.64	1.6	5							○														
	PNEG110512R-CR	5.4	15.875	5.56	4.64	1.6	5							●	●													
	PNEG110512L-CR	5.4	15.875	5.56	4.64	1.6	5							○														

PN**

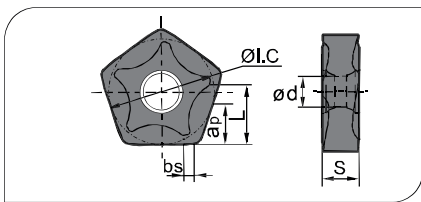

- Ideal Machining Condition / Gute Bearbeitungsbedingungen
- ⊗ Normal Machining Condition / Normale Bearbeitungsbedingungen
- ⊗ Unfavorable Machining Condition / Ungünstige Bearbeitungsbedingungen

Workpiece Material / Werkstoffe	Steel / Stahl		Stainless Steel / Rostfreier Stahl		Cast iron / Gusseisen		Non-ferrite material / Ne Metalle		Heat-resistant steel / Warmfester Stahl	
	P	M	K	N	S	P	M	K	N	S
P	●	●	●	●	●	●	●	●	●	●
M		●	●	●	●	●	●	●	●	●
K						●	●	●		●
N									●	●
S						●	●			

Insert WSP	Insert Typ	Dimension (mm) / Abmessung						CVD Coating / CVD Beschicht.					PVD Coating / PVD Beschicht.					Cermet / Cermet	Carbide uncoat. / unbe. Hartmetall									
		L	ØI.C	S	ød	bs	apmax	YBC301	YBC302	YBC401	YBM251	YBM253	YBM351	YBD152	YBD252	YBG102	YBG202		YBG205	YBG302	YBG152	YBG252	YNG151	YNG151C	YC30S	YD101	YD201	
	PNEG110512R-PF	7.5	15.875	5.56	4.64	1.4	7.5	●			○																	
	PNEG110512L-PF	7.5	15.875	5.56	4.64	1.4	7.5	○			○																	
	PNEG110512R-PM	7.5	15.875	5.56	4.64	1.4	7.5	●			●																	
	PNEG110512L-PM	7.5	15.875	5.56	4.64	1.4	7.5	○			●																	
	PNEG110512R-PR	7.5	15.875	5.56	4.64	1.4	7.5	●			●																	
	PNEG110512L-PR	7.5	15.875	5.56	4.64	1.4	7.5	○			○																	

QC**L

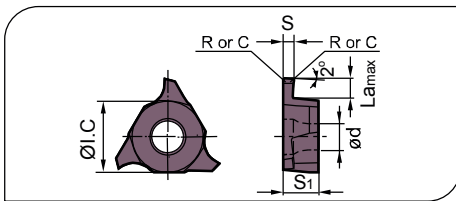

- Ideal Machining Condition / Gute Bearbeitungsbedingungen
- Normal Machining Condition / Normale Bearbeitungsbedingungen
- Unfavorable Machining Condition / Ungünstige Bearbeitungsbedingungen

Workpiece Material / Werkstoffe	P	M	K	N	S
Steel / Stahl	●	●	●	●	●
Stainless Steel / Rostfreier Stahl		●	●	●	●
Cast iron / Gusseisen			●	●	●
Non-ferrous material / Ne Metalle				●	●
Heat-resistant steel / Warmfester Stahl					●

Insert WSP	Type Typ	Dimensions (mm) / Abmessungen						CVD Coating / CVD Beschicht.						PVD Coating / PVD Beschicht.				Cermet / Cermet	Carbide uncoat. / unbe. Hartmetall							
		S±0.025	La _{max}	R/C	ØI.C	S ₁	ød	YBC301	YBC302	YBC401	YBM251	YBM253	YBM351	YBD152	YBD252	YBG102	YBG202		YBG205	YBG302	YBG152	YBG252	YNG151	YNG151C	YC30S	YD101
	QC16L110-R01	1.10	2.00	R0.1	9.525	3.18	4.4									○	●									
	QC16L125-R02	1.25	2.00	R0.2	9.525	3.18	4.4									○	●									
	QC16L145-R02	1.45	2.00	R0.2	9.525	3.18	4.4									○	●									
	QC16L150-R02	1.50	2.00	R0.2	9.525	3.18	4.4									○	●									
	QC16L175-R02	1.75	2.00	R0.2	9.525	3.18	4.4									○	●									
	QC16L185-R02	1.85	2.50	R0.2	9.525	3.18	4.4									○	●									
	QC16L200-R02	2.00	2.50	R0.2	9.525	3.18	4.4									○	●									
	QC16L250-R02	2.50	2.50	R0.2	9.525	3.18	4.4									○	●									
	QC16L300-R02	3.00	3.00	R0.2	9.525	3.18	4.4									○	●									

B

Milling Tools
Fräser

Milling · Fräsen

Indexable Milling Tools · Wendepplattenfräser

QC**L

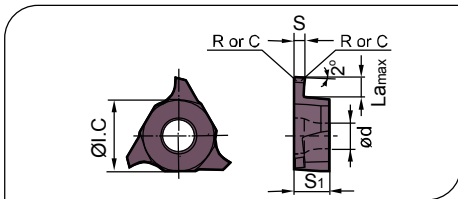

- Ideal Machining Condition / Gute Bearbeitungsbedingungen
- Normal Machining Condition / Normale Bearbeitungsbedingungen
- Unfavorable Machining Condition / Ungünstige Bearbeitungsbedingungen

Workpiece Material / Werkstoffe	P	M	K	N	S	Steel / Stahl	Stainless Steel / Rostfreier Stahl	Cast iron / Gusseisen	Non-ferrous material / Ne Metalle	Heat-resistant steel / Warmfester Stahl
P	●	●	●	●	●	●	●	●	●	●
M		●	●	●	●		●	●	●	●
K			●					●		
N				●					●	
S					●					●

Insert WSP	Type Typ	Dimensions (mm) / Abmessungen						CVD Coating / CVD Beschicht.					PVD Coating / PVD Beschicht.					Cermets / Cermet	Carbide uncoat. / unbe. Hartmetall						
		S±0.025	Lamax	R/C	ØI.C	S1	ød	YBC301	YBC302	YBC401	YBM251	YBM253	YBM351	YBD152	YBD252	YBG102	YBG202		YBG205	YBG302	YBG152	YBG252	YNG151	YNG151C	YC30S
	QC22L125-R02	1.25	2.00	R0.2	12.70	4.76	5.5									○	●								
	QC22L145-R02	1.45	2.00	R0.2	12.70	4.76	5.5									○	●								
	QC22L150-R02	1.50	3.50	R0.2	12.70	4.76	5.5									○	●								
	QC22L175-R02	1.75	3.50	R0.2	12.70	4.76	5.5									○	●								
	QC22L185-R02	1.85	3.50	R0.2	12.70	4.76	5.5									○	●								
	QC22L200-R02	2.00	3.50	R0.2	12.70	4.76	5.5									○	●								
	QC22L230-R02	2.30	3.50	R0.2	12.70	4.76	5.5									○	●								
	QC22L250-R03	2.50	4.00	R0.3	12.70	4.76	5.5									○	●								
	QC22L265-R03	2.65	4.00	R0.3	12.70	4.76	5.5									○	●								
	QC22L280-R03	2.80	4.00	R0.3	12.70	4.76	5.5									○	●								
	QC22L300-R03	3.00	4.00	R0.3	12.70	4.76	5.5									○	●								
	QC22L320-R03	3.20	4.00	R0.3	12.70	4.76	5.5									○	●								
	QC22L330-R03	3.30	4.00	R0.3	12.70	4.76	5.5									○	●								
	QC22L350-R03	3.50	5.00	R0.3	12.70	4.76	5.5									○	●								
	QC22L400-R04	4.00	5.00	R0.4	12.70	4.76	5.5									○	○								
	QC22L430-R04	4.30	5.00	R0.4	12.70	4.76	5.5									○	○								
	QC22L450-R04	4.50	5.00	R0.4	12.70	4.76	5.5									○	○								
QC22L480-R04	4.80	5.00	R0.4	12.70	5.06	5.5									○	○									

● Ex Stock / ab Lager ○ On demand / auf Anfrage

RC**

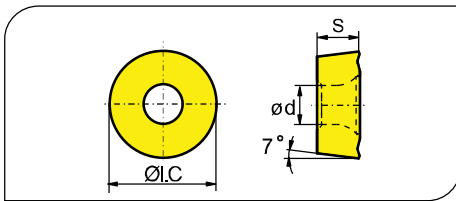

- Ideal Machining Condition / Gute Bearbeitungsbedingungen
- ⊗ Normal Machining Condition / Normale Bearbeitungsbedingungen
- ⊗ Unfavorable Machining Condition / Ungünstige Bearbeitungsbedingungen

Workpiece Material / Werkstoffe	P	M	K	N	S	YBC301	YBC302	YBC401	YBM251	YBM253	YBM351	YBD152	YBD252	YBG102	YBG202	YBG205	YBG302	YBG152	YBG252	YNG151	YNG151C	YC30S	YD101	YD201
Steel / Stahl	●	●	●	●	●	●	●	●	●	●	●	●	●	●	●	●	●	●	●	●	●	●	●	●
Stainless Steel / Rostfreier Stahl	●	●	●	●	●	●	●	●	●	●	●	●	●	●	●	●	●	●	●	●	●	●	●	●
Cast iron / Gusseisen	●	●	●	●	●	●	●	●	●	●	●	●	●	●	●	●	●	●	●	●	●	●	●	●
Non-ferrite material / Ne Metalle	●	●	●	●	●	●	●	●	●	●	●	●	●	●	●	●	●	●	●	●	●	●	●	●
Heat-resistant steel / Warmfester Stahl	●	●	●	●	●	●	●	●	●	●	●	●	●	●	●	●	●	●	●	●	●	●	●	●

Insert shape WSP	Type Typ	Dimension (mm) / Abmessung			CVD Coating / CVD Beschicht.								PVD Coating / PVD Beschicht.					Cemet / Cemet		Carbide uncoat. / unbe. Hartmetall				
		I.C	S	d	YBC301	YBC302	YBC401	YBM251	YBM253	YBM351	YBD152	YBD252	YBG102	YBG202	YBG205	YBG302	YBG152	YBG252	YNG151	YNG151C	YC30S	YD101	YD201	
	RCKT10T3MO-DM	10.0	3.97	4.4	●	●								●		○								
	RCKT1204MO-DM	12.0	4.76	4.0	●	●	●			●	○			●		○								
	RCKT1606MO-DM	16.0	6.35	5.56	●	●	○									○	●							
	RCKT2006MO-DM	20.0	6.35	6.55	○	○	○																	
	RCKT1204MO-DR	12.0	4.76	4.0	●	●	●			●						○								
	RCKT1606MO-DR	16.0	6.35	5.56	●	●				●		●												
	RCKT2006MO-DR	20.0	6.35	6.55	●	●				●		●												
	RCKT1204MO-ER	12.0	4.76	4.0						●	○													
	RCKT1606MO-ER	16.0	6.35	5.56						●	○													
	RCKT2006MO-ER	20.0	6.35	6.55						●	○													

RD**

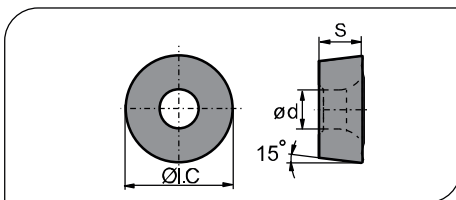

- Ideal Machining Condition / Gute Bearbeitungsbedingungen
- ⊗ Normal Machining Condition / Normale Bearbeitungsbedingungen
- ⊗ Unfavorable Machining Condition / Ungünstige Bearbeitungsbedingungen

Workpiece Material / Werkstoffe	P	M	K	N	S	YBC301	YBC302	YBC401	YBM251	YBM253	YBM351	YBD152	YBD252	YBG102	YBG202	YBG205	YBG302	YBG152	YBG252	YNG151	YNG151C	YC30S	YD101	YD201
Steel / Stahl	●	●	●	●	●	●	●	●	●	●	●	●	●	●	●	●	●	●	●	●	●	●	●	●
Stainless Steel / Rostfreier Stahl	●	●	●	●	●	●	●	●	●	●	●	●	●	●	●	●	●	●	●	●	●	●	●	●
Cast iron / Gusseisen	●	●	●	●	●	●	●	●	●	●	●	●	●	●	●	●	●	●	●	●	●	●	●	●
Non-ferrite material / Ne Metalle	●	●	●	●	●	●	●	●	●	●	●	●	●	●	●	●	●	●	●	●	●	●	●	●
Heat-resistant steel / Warmfester Stahl	●	●	●	●	●	●	●	●	●	●	●	●	●	●	●	●	●	●	●	●	●	●	●	●

Insert shape Plattenform	Type Typ	Dimension (mm) / Abmessung			CVD Coating / CVD Beschicht.								PVD Coating / PVD Beschicht.					Cemet / Cemet		Carbide uncoat. / unbe. Hartmetall				
		I.C	S	d	YBC301	YBC302	YBC401	YBM251	YBM253	YBM351	YBD152	YBD252	YBG102	YBG202	YBG205	YBG302	YBG152	YBG252	YNG151	YNG151C	YC30S	YD101	YD201	
	RDKW0702MO	7.0	2.38	2.7						●				●	●									
	RDKW0803MO	8.0	3.18	3.4						●					●									
	RDKW1003MO	10.0	3.18	3.9				●		●				●	●									
	RDKW10T3MO	10.0	3.97	4.4	○	●				●				●	●									
	RDKW1204MO	12.0	4.76	4.4	○	●		●		●				●	●	●	○							
	RDKW12T3MO	12.0	3.97	3.9			○	●		●				●	●								○	
	RDKT12T3MO-EM	12.0	3.97	3.9						●														
	RDKW1604MO	16.0	4.76	5.2						●				●	●									
	RDKW1605MO	16.0	5.56	5.5						●					●		●							
	RDKW2006MO	20.0	6.35	6.5	●					●		○												

Milling - Fräsen

Indexable Milling Tools - Wendepplattenfräser

RO**

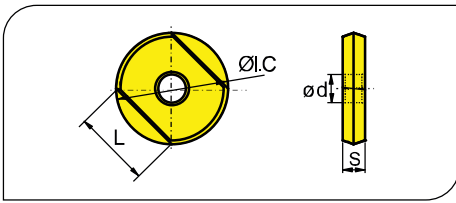

- Ideal Machining Condition / Gute Bearbeitungsbedingungen
- ⊙ Normal Machining Condition / Normale Bearbeitungsbedingungen
- ⊗ Unfavorable Machining Condition / Ungünstige Bearbeitungsbedingungen

Workpiece Material / Werkstoffe	Steel / Stahl				Stainless Steel / Rostfreier Stahl				Cast iron / Gusseisen				Non-ferite material / Ne Metalle				Heat-resistant steel / Warmfester Stahl			
	P	M	K	N	S	P	M	K	N	S	P	M	K	N	S	P	M	K	N	S
P	●	●	●	●	●	●	●	●	●	●	●	●	●	●	●	●	●	●	●	●
M	●	●	●	●	●	●	●	●	●	●	●	●	●	●	●	●	●	●	●	●
K	●	●	●	●	●	●	●	●	●	●	●	●	●	●	●	●	●	●	●	●
N	●	●	●	●	●	●	●	●	●	●	●	●	●	●	●	●	●	●	●	●
S	●	●	●	●	●	●	●	●	●	●	●	●	●	●	●	●	●	●	●	●

Insert WSP	Type Typ	Dimensions (mm) / Abmessungen				CVD Coating / CVD Beschicht.				PVD Coating / PVD Beschicht.				Cermets / Cermet	Carbide uncoat. / unbe. Hartmetall										
		I.C	L	S	d	YBC301	YBC302	YBC401	YBM251	YBM253	YBM351	YBD152	YBD252		YBG102	YBG202	YBG205	YBG302	YBG152	YBG252	YNG151	YNG151C	YC30S	YD101	YD201
	ROHX1203	12	8.5	3	4						○			○	●			●							
	ROHX1604	16	11.3	4	5						○				●				●						
	ROHX2005	20	14.1	5	5						●				●				●						

SD**

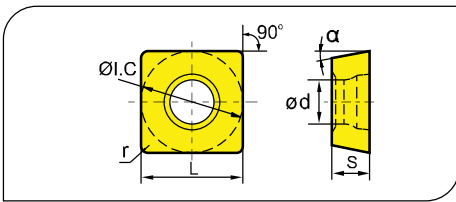

- Ideal Machining Condition / Gute Bearbeitungsbedingungen
- ⊙ Normal Machining Condition / Normale Bearbeitungsbedingungen
- ⊗ Unfavorable Machining Condition / Ungünstige Bearbeitungsbedingungen

Workpiece Material / Werkstoffe	Steel / Stahl				Stainless Steel / Rostfreier Stahl				Cast iron / Gusseisen				Non-ferite material / Ne Metalle				Heat-resistant steel / Warmfester Stahl							
	P	M	K	N	S	P	M	K	N	S	P	M	K	N	S	P	M	K	N	S				
P	●	●	●	●	●	●	●	●	●	●	●	●	●	●	●	●	●	●	●	●	●	●	●	●
M	●	●	●	●	●	●	●	●	●	●	●	●	●	●	●	●	●	●	●	●	●	●	●	●
K	●	●	●	●	●	●	●	●	●	●	●	●	●	●	●	●	●	●	●	●	●	●	●	●
N	●	●	●	●	●	●	●	●	●	●	●	●	●	●	●	●	●	●	●	●	●	●	●	●
S	●	●	●	●	●	●	●	●	●	●	●	●	●	●	●	●	●	●	●	●	●	●	●	●

Insert WSP	Type Typ	Dimensions (mm) / Abmessungen						CVD Coating / CVD Beschicht.				PVD Coating / PVD Beschicht.				Cermets / Cermet	Carbide uncoat. / unbe. Hartmetall								
		r	L	I.C	S	d	α	YBC301	YBC302	YBC401	YBM251	YBM253	YBM351	YBD152	YBD252		YBG102	YBG202	YBG205	YBG302	YBG152	YBG252	YNG151	YNG151C	YC30S
	SDMT090308	0.8	9.525	9.525	3.18	4.4	15°				●	○													

SD**

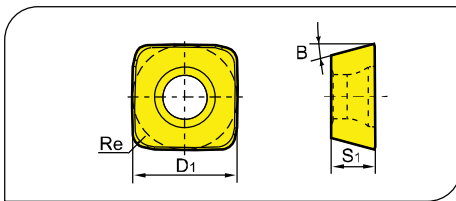

- Ideal Machining Condition / Gute Bearbeitungsbedingungen
- ⊙ Normal Machining Condition / Normale Bearbeitungsbedingungen
- ⊗ Unfavorable Machining Condition / Ungünstige Bearbeitungsbedingungen

Workpiece Material / Werkstoffe	Steel / Stahl				Stainless Steel / Rostfreier Stahl				Cast iron / Gusseisen				Non-ferite material / Ne Metalle				Heat-resistant steel / Warmfester Stahl							
	P	M	K	N	S	P	M	K	N	S	P	M	K	N	S	P	M	K	N	S				
P	●	●	●	●	●	●	●	●	●	●	●	●	●	●	●	●	●	●	●	●	●	●	●	●
M	●	●	●	●	●	●	●	●	●	●	●	●	●	●	●	●	●	●	●	●	●	●	●	●
K	●	●	●	●	●	●	●	●	●	●	●	●	●	●	●	●	●	●	●	●	●	●	●	●
N	●	●	●	●	●	●	●	●	●	●	●	●	●	●	●	●	●	●	●	●	●	●	●	●
S	●	●	●	●	●	●	●	●	●	●	●	●	●	●	●	●	●	●	●	●	●	●	●	●

Insert WSP	Type Typ	Dimensions (mm) / Abmessungen				CVD Coating / CVD Beschicht.				PVD Coating / PVD Beschicht.				Cermets / Cermet	Carbide uncoat. / unbe. Hartmetall									
		B	Re	S1	D1	YBC301	YBC302	YBC401	YBM251	YBM253	YBM351	YBD152	YBD252		YBG102	YBG202	YBG205	YBG302	YBG152	YBG252	YNG151	YNG151C	YC30S	YD101
	SDMT09T312-DM	15°	1.2	3.97	9.525						●	○												
	SDMT120412-DM	15°	1.2	4.76	12.7						●	○												

● Ex Stock / ab Lager ○ On demand / auf Anfrage

SD**

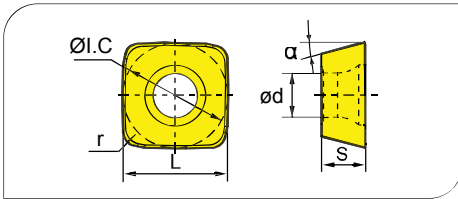

- Ideal Machining Condition / Gute Bearbeitungsbedingungen
- Normal Machining Condition / Normale Bearbeitungsbedingungen
- Unfavorable Machining Condition / Ungünstige Bearbeitungsbedingungen

Workpiece Material / Werkstoffe	P	M	K	N	S	YBC301	YBC302	YBC401	YBM251	YBM253	YBM351	YBD152	YBD252	YBG102	YBG202	YBG205	YBG302	YBG152	YBG252	YNG151	YNG151C	YC30S	YD101	YD201
P Steel / Stahl	●	●	●	●	●	●	●	●	●	●	●	●	●	●	●	●	●	●	●	●	●	●	●	●
M Stainless Steel / Rostfreier Stahl		●	●	●	●				●	●	●				●	●	●			●	●	●		
K Cast iron / Gusseisen												●	●							●	●			●
N Non-ferrite material / Ne Metalle																							●	●
S Heat-resistant steel / Warmfester Stahl									●	●				●	●	●								



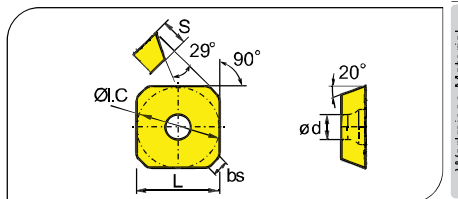

Insert WSP	Type Typ	Dimensions (mm) Abmessungen						CVD Coating CVD Beschicht.						PVD Coating PVD Beschicht.						Cemet Cemet	Carbide uncoat unbe. Hartmetall				
		ØI.C	L	r	S	ød	α	YBC301	YBC302	YBC401	YBM251	YBM253	YBM351	YBD152	YBD252	YBG102	YBG202	YBG205	YBG302		YBG152	YBG252	YNG151	YNG151C	YC30S
New! 	SDMT09T312-PM	9.525	9.525	1.2	3.97	4.0	15°		○			●							●	○					
	SDMT120412-PM	12.7	12.7	2.0	4.76	4.4	15°		○			●							●	○					

SE**



- Ideal Machining Condition / Gute Bearbeitungsbedingungen
- Normal Machining Condition / Normale Bearbeitungsbedingungen
- Unfavorable Machining Condition / Ungünstige Bearbeitungsbedingungen

Workpiece Material / Werkstoffe	P	M	K	N	S	YBC301	YBC302	YBC401	YBM251	YBM253	YBM351	YBD152	YBD252	YBG102	YBG202	YBG205	YBG302	YBG152	YBG252	YNG151	YNG151C	YC30S	YD101	YD201
P Steel / Stahl	●	●	●	●	●	●	●	●	●	●	●	●	●	●	●	●	●	●	●	●	●	●	●	●
M Stainless Steel / Rostfreier Stahl		●	●	●	●				●	●	●				●	●	●			●	●	●		
K Cast iron / Gusseisen												●	●							●	●			●
N Non-ferrite material / Ne Metalle																							●	●
S Heat-resistant steel / Warmfester Stahl									●	●				●	●	●								

Insert WSP	Type Typ	Dimensions (mm) Abmessungen						CVD Coating CVD Beschicht.						PVD Coating PVD Beschicht.						Cemet Cemet	Carbide uncoat unbe. Hartmetall			
		L	I.C	S	d	bs	R	YBC301	YBC302	YBC401	YBM251	YBM253	YBM351	YBD152	YBD252	YBG102	YBG202	YBG205	YBG302		YBG152	YBG252	YNG151	YNG151C
	SEET12T3-DF	13.40	13.40	3.97	4.1	2.55		●	●		●	●						●	○		○			
	SEET12T3-CF	13.40	13.40	3.97	4.1	2.55								●				○						●
	SEET12T3-EF	13.40	13.40	3.97	4.1	2.55												●	●					
	SEET12T3-DM	13.40	13.40	3.97	4.1	2.55		●	●	●	●	●						●	●					
	SEET12T3-CM	13.40	13.40	3.97	4.1	2.55								●				○						○
	SEET12T3-EM	13.40	13.40	3.97	4.1	2.55					●	○	●				●	●						
	SEET12T3-DR	13.40	13.40	3.97	4.1	2.55		●	●			●		●		○		○						
	SEET12T3-CR	13.40	13.40	3.97	4.1	2.55								●	●		○		○					
	SEET12T3-LH	13.40	13.40	3.97	4.1	2.55																	●	●
	SEET12T3-W	17.82	13.40	3.97	4.1	9.46	500				○			○				●	○		○			

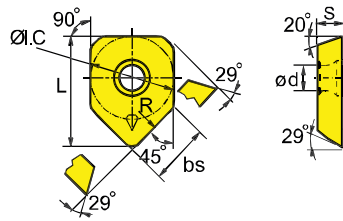

Applicable tool B11-B18
Werkzeug

Tools code key B184-B185
WSP ISO

Grade selection guide B19-B23
Sortenauswahl

Technical data B215-B220
Technische Daten

Milling · Fräsen

Indexable Milling Tools · Wendeplattenfräser

SE**

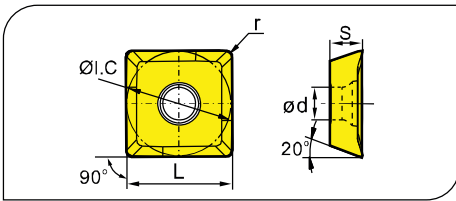

- Ideal Machining Condition / Gute Bearbeitungsbedingungen
- Normal Machining Condition / Normale Bearbeitungsbedingungen
- Unfavorable Machining Condition / Ungünstige Bearbeitungsbedingungen

Workpiece Material / Werkstoffe	P	M	K	N	S
P Steel / Stahl	●	●	●	●	●
M Stainless Steel / Rostfreier Stahl	●	●	●	●	●
K Cast iron / Gusseisen	●	●	●	●	●
N Non-ferrous material / Ne Metalle	●	●	●	●	●
S Heat-resistant steel / Warmfester Stahl	●	●	●	●	●

Insert WSP	Type Typ	Dimensions (mm) / Abmessungen					CVD Coating / CVD Beschicht.						PVD Coating / PVD Beschicht.				Cermet Cermet	Carbide uncoat. / unbe. Hartmetall								
		L	I.C	S	d	r	YBC301	YBC302	YBC401	YBM251	YBM253	YBM351	YBD152	YBD252	YBG102	YBG202		YBG205	YBG302	YBG152	YBG252	YNG151	YNG151C	YC30S	YD101	YD201
	SEET09T308PER-PF	9.525	9.525	4.01	3.3	0.8										●										
	SEET09T308PER-PM	9.525	9.525	4.01	3.3	0.8							●			●										
	SEET09T308PER-PR	9.525	9.525	4.01	3.3	0.8							●													
	SEET120308PER-PF	13.308	13.308	4.04	4.1	0.8	●	●				○				●										
	SEET120308PER-PM	13.308	13.308	4.04	4.1	0.8		●	●	●	●	●	●	●	●	●	●									
	SEET120308PER-PR	13.308	13.308	4.04	4.1	0.8		●	●	●	●	●	○	○	○											
	SEET120308-LH	13.308	13.308	4.04	4.1	0.8									○									●		

● Ex Stock / ab Lager ○ On demand / auf Anfrage

SE**

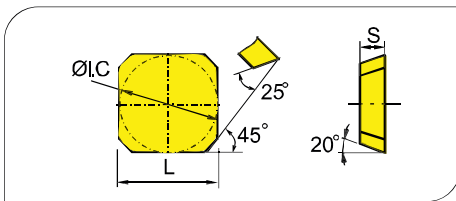

- Ideal Machining Condition / Gute Bearbeitungsbedingungen
- Normal Machining Condition / Normale Bearbeitungsbedingungen
- Unfavorable Machining Condition / Ungünstige Bearbeitungsbedingungen

Workpiece Material / Werkstoffe	P	M	K	N	S	YBC301	YBC302	YBC401	YBM251	YBM253	YBM351	YBD152	YBD252	YBG102	YBG202	YBG205	YBG302	YBG152	YBG252	YNG151	YNG151C	YC30S	YD101	YD201
P Steel Stahl	●	●	●	●	●	●	●	●	●	●	●	●	●	●	●	●	●	●	●	●	●	●	●	●
M Stainless Steel Rostfreier Stahl		●	●	●	●				●	●	●				●	●	●			●	●	●		
K Cast iron Gusseisen			●									●	●							●	●			●
N Non-ferrite material Ne Metalle				●																		●	●	
S Heat-resistant steel Warmfester Stahl					●				●	●				●		●	●							

Insert WSP	Type Typ	Dimensions (mm) Abmessungen			CVD Coating CVD Beschicht.								PVD Coating PVD Beschicht.					Cermet Cermet	Carbide uncoat. unbe. Hartmetall						
		L	I.C	S	YBC301	YBC302	YBC401	YBM251	YBM253	YBM351	YBD152	YBD252	YBG102	YBG202	YBG205	YBG302	YBG152	YBG252	YNG151	YNG151C	YC30S	YD101	YD201		
	SEEN1203AFTN	12.7	12.7	3.18																●					
	SEKN1203AFFN	12.7	12.7	3.18																					
	SEKN1203AFN	12.7	12.7	3.18	○																		●	○	
	SEKN1203AFTN	12.7	12.7	3.18	●			●	●												●	○	●		○
	SEKN1203AFS13N	12.7	12.7	3.18	○																				
	SEKN1204AFN	12.7	12.7	4.76	●																				○
	SEKN1204AFTN	12.7	12.7	4.76	●																				○
	SEKN1204AFS13N	12.7	12.7	4.76	○																				
	SEKN1504AFN	15.875	15.875	4.76	○																			○	○
	SEKN1504AFTN	15.875	15.875	4.76	●		●	●		●												○			
	SEKN1504AFZN	15.875	15.875	4.76																					
	SEKN1204AZ	15.875	15.875	4.76	●	○																			○
	SEKN1504AZ	15.875	15.875	4.76	●	○																			○

SE**

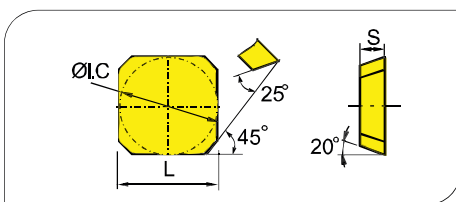

- Ideal Machining Condition / Gute Bearbeitungsbedingungen
- Normal Machining Condition / Normale Bearbeitungsbedingungen
- Unfavorable Machining Condition / Ungünstige Bearbeitungsbedingungen

Workpiece Material / Werkstoffe	P	M	K	N	S	YBC301	YBC302	YBC401	YBM251	YBM253	YBM351	YBD152	YBD252	YBG102	YBG202	YBG205	YBG302	YBG152	YBG252	YNG151	YNG151C	YC30S	YD101	YD201
P Steel Stahl	●	●	●	●	●	●	●	●	●	●	●	●	●	●	●	●	●	●	●	●	●	●	●	●
M Stainless Steel Rostfreier Stahl		●	●	●	●				●	●	●				●	●	●			●	●	●		
K Cast iron Gusseisen			●									●	●							●	●			●
N Non-ferrite material Ne Metalle				●																			●	●
S Heat-resistant steel Warmfester Stahl					●				●	●				●		●	●							

Insert WSP	Type Typ	Dimensions (mm) Abmessungen			CVD Coating CVD Beschicht.								PVD Coating PVD Beschicht.					Cermet Cermet	Carbide uncoat. unbe. Hartmetall					
		L	I.C	S	YBC301	YBC302	YBC401	YBM251	YBM253	YBM351	YBD152	YBD252	YBG102	YBG202	YBG205	YBG302	YBG152	YBG252	YNG151	YNG151C	YC30S	YD101	YD201	
	SEKR1203AFN	12.7	12.7	3.18	●	○									●									
	SEKR1504AFN	15.875	15.875	4.76																				

Applicable tool B11-B18
Werkzeug

Tools code key B184-B185
WSP ISO

Grade selection guide B19-B23
Sortenauswahl

Technical data B215-B220
Technische Daten

Milling - Fräsen

Indexable Milling Tools - Wendepplattenfräser

SN**

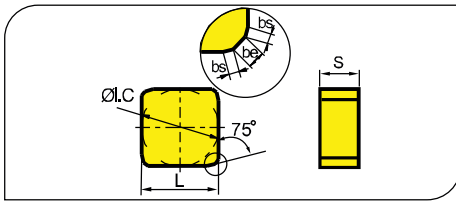

- Ideal Machining Condition / Gute Bearbeitungsbedingungen
- ⊙ Normal Machining Condition / Normale Bearbeitungsbedingungen
- ⊗ Unfavorable Machining Condition / Ungünstige Bearbeitungsbedingungen

Workpiece Material / Werkstoffe	CVD Coating / CVD Beschicht.						PVD Coating / PVD Beschicht.						Cermet / Cermet	Carbide uncoat. / unbe. Hartmetall					
	YBC301	YBC302	YBC401	YBM251	YBM253	YBM351	YBD152	YBD252	YBG102	YBG202	YBG205	YBG302		YBG152	YBG252	YNG151	YNG151C	YC30S	YD101
P Steel / Stahl	●	●	●	●	●	●	●	●	●	●	●	●	●	●	●	●			
M Stainless Steel / Rostfreier Stahl			⊙	⊙	⊙	⊙													
K Cast iron / Gusseisen							⊗	⊗	⊗	⊗	⊗	⊗	⊗	⊗	⊗	⊗			
N Non-ferrous material / Ne Metalle																	⊙	⊙	⊙
S Heat-resistant steel / Warmfester Stahl							⊗	⊗					⊗	⊗					

Insert WSP	Type Typ	Dimensions (mm) / Abmessungen					CVD Coating / CVD Beschicht.						PVD Coating / PVD Beschicht.						Cermet / Cermet	Carbide uncoat. / unbe. Hartmetall						
		L	I.C	S	be	bs	YBC301	YBC302	YBC401	YBM251	YBM253	YBM351	YBD152	YBD252	YBG102	YBG202	YBG205	YBG302		YBG152	YBG252	YNG151	YNG151C	YC30S	YD101	YD201
	SNKN1204ENN	12.7	12.7	4.76	0.9	1.5	●					⊙	●											●		⊙
	SNKN1504ENN	15.875	15.875	4.76	0.9	1.5	⊙					⊙												●		⊙
	SNKN1904ENN	19.05	19.05	4.76	1.0	1.5																				

SN**

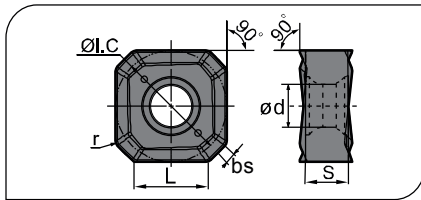

- Ideal Machining Condition / Gute Bearbeitungsbedingungen
- ⊙ Normal Machining Condition / Normale Bearbeitungsbedingungen
- ⊗ Unfavorable Machining Condition / Ungünstige Bearbeitungsbedingungen

Workpiece Material / Werkstoffe	CVD Coating / CVD Beschicht.								PVD Coating / PVD Beschicht.						Cermet / Cermet	Carbide uncoat. / unbe. Hartmetall			
	YBC301	YBC302	YBC401	YBM251	YBM253	YBM351	YBD152	YBD252	YBG102	YBG202	YBG205	YBG302	YBG152	YBG252		YNG151	YNG151C	YC30S	YD101
P Steel / Stahl	●	●	●	●	●	●	●	●	●	●	●	●	●	●	●	●			
M Stainless Steel / Rostfreier Stahl			⊙	⊙	⊙	⊙													
K Cast iron / Gusseisen							⊗	⊗	⊗	⊗	⊗	⊗	⊗	⊗	⊗	⊗			
N Non-ferrous material / Ne Metalle																	⊙	⊙	⊙
S Heat-resistant steel / Warmfester Stahl							⊗	⊗					⊗	⊗					

Insert WSP	Type Typ	Dimensions (mm) / Abmessungen						CVD Coating / CVD Beschicht.								PVD Coating / PVD Beschicht.						Cermet / Cermet	Carbide uncoat. / unbe. Hartmetall			
		L	ØI.C	S	bs	ød	r	YBC301	YBC302	YBC401	YBM251	YBM253	YBM351	YBD152	YBD252	YBG102	YBG202	YBG205	YBG302	YBG152	YBG252		YNG151	YNG151C	YC30S	YD101
	SNEG1205ANR-GM	7.6	12.0	4.76	1.05	4.6	0.8	●					●													
	SNEG1506ANR-GM	7.6	15.0	5.54	1.30	5.5	0.9	●					●													
	SNEG1506ANR-GR	9.4	15.0	5.54	1.30	5.5	0.9						●		●											
	SNEG1907ANR-GR	12.1	19.0	7.0	1.67	7.2	1.0						⊙													

● Ex Stock / ab Lager ⊙ On demand / auf Anfrage

SP*N

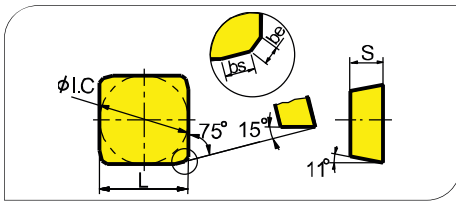

- Ideal Machining Condition / Gute Bearbeitungsbedingungen
- Normal Machining Condition / Normale Bearbeitungsbedingungen
- Unfavorable Machining Condition / Ungünstige Bearbeitungsbedingungen

Workpiece Material / Werkstoffe	Steel / Stahl		Stainless Steel / Rostfreier Stahl		Cast iron / Gusseisen		Non-ferrous material / Ne Metalle		Heat-resistant steel / Warmfester Stahl	
	P	M	K	N	S					
Steel / Stahl	●	●	●	●	●	●	●	●	●	●
Stainless Steel / Rostfreier Stahl		●	●	●	●	●	●	●	●	●
Cast iron / Gusseisen			●	●	●	●	●	●	●	●
Non-ferrous material / Ne Metalle				●	●	●	●	●	●	●
Heat-resistant steel / Warmfester Stahl						●	●	●	●	●

Insert WSP	Type Typ	Dimensions (mm) / Abmessungen					CVD Coating / CVD Beschicht.						PVD Coating / PVD Beschicht.			Cermet / Cermet	Carbide uncoat / unbe. Hartmetall										
		L	I.C	S	be	bs	YBC301	YBC302	YBC401	YBM251	YBM253	YBM351	YBD152	YBD252	YBG102	YBG202	YBG205	YBG302	YBG152	YBG252	YNG151	YNG151C	YC30S	YD101	YD201		
	SPAN1203EDEL	12.7	12.7	1.4	1	3.18	●																				
	SPAN1203EDER	12.7	12.7	1.4	1	3.18	●																				
	SPAN1203EDFL	12.7	12.7	1.4	1	3.18																				○	
	SPAN1203EDFR	12.7	12.7	1.4	1	3.18																				●	
	SPAN1203EDL	12.7	12.7	1.4	1	3.18																					
	SPAN1203EDR	12.7	12.7	1.4	1	3.18																					○
	SPAN1504EDFR	15.875	15.875	1.4	1	4.76																					○
SPAN1504EDFL	15.875	15.875	1.4	1	4.76																					○	
	SPCN1203EDSKR	12.7	12.7	1.4	1	3.18	●																			○	
	SPCN1504EDSKR	15.875	15.875	1.4	1	4.76	●																			○	

B

Milling Tools
Fräser

Applicable tool / Werkzeug **B11-B18**

Tools code key / WSP ISO **B184-B185**

Grade selection guide / Sortenauswahl **B19-B23**

Technical data / Technische Daten **B215-B220**

Milling - Fräsen

Indexable Milling Tools - Wendepplattenfräser

SP*N

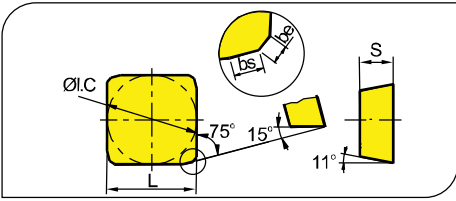

- Ideal Machining Condition / Gute Bearbeitungsbedingungen
- Normal Machining Condition / Normale Bearbeitungsbedingungen
- Unfavorable Machining Condition / Ungünstige Bearbeitungsbedingungen

Workpiece Material / Werkstoffe	CVD Coating / CVD Beschicht.										PVD Coating / PVD Beschicht.			Cermets / Cermet		Carbide uncoat. / unbe. Hartmetall								
	P	M	K	N	S	YBC301	YBC302	YBC401	YBM251	YBM253	YBM351	YBD152	YBD252	YBG102	YBG202	YBG205	YBG302	YBG152	YBG252	YNG151	YNG151C	YC30S	YD101	YD201
Steel / Stahl	●	●	●	●	●	●	●	●	●	●	●	●	●	●	●	●	●	●	●	●	●	●	●	●
Stainless Steel / Rostfreier Stahl	●	●	●	●	●	●	●	●	●	●	●	●	●	●	●	●	●	●	●	●	●	●	●	●
Cast iron / Gusseisen																								
Non-ferrous material / Ne Metalle																								
Heat-resistant steel / Warmfester Stahl																								

Insert WSP	Type Typ	Dimensions (mm) / Abmessungen					CVD Coating / CVD Beschicht.								PVD Coating / PVD Beschicht.					Cermets / Cermet		Carbide uncoat. / unbe. Hartmetall			
		L	I.C	S	be	bs	YBC301	YBC302	YBC401	YBM251	YBM253	YBM351	YBD152	YBD252	YBG102	YBG202	YBG205	YBG302	YBG152	YBG252	YNG151	YNG151C	YC30S	YD101	YD201
	SPKN1203EDER	12.7	12.7	3.18	1	1.4																			
	SPKN1203EDEL	12.7	12.7	3.18	1	1.4																			
	SPKN1203EDFR	12.7	12.7	3.18	1	1.4	○								○									○	●
	SPKN1203EDFL (SPKN1203EDL)	12.7	12.7	3.18	1	1.4																			●
	SPKN1203EDSKR (SPKN1203EDR)	12.7	12.7	3.18	1	1.4	●	●							●	●	●						○		
	SPKN1203EDSKL (SPKN1203EDL)	12.7	12.7	3.18	1	1.4	●									●								●	
	SPKN1203EDTKR	12.7	12.7	3.18	1	1.4						○							○					●	
	SPKN1203EDTKL	12.7	12.7	3.18	1	1.4																			
	SPKN1203EDS31PR (SPKN1203EDT31R)	12.7	12.7	3.18	1	1.4											○								
	SPKN1203EDS31PL (SPKN1203EDT31L)	12.7	12.7	3.18	1	1.4																			
	SPKN1203EDT31R	12.7	12.7	3.18	1	1.4																			
SPKN1203EDT31L	12.7	12.7	3.18	1	1.4																				
	SPKN1204EDFL (SPKN1204EDL)	12.7	12.7	4.76	1	1.4																			
	SPKN1204EDER (SPKN1204EDR)	12.7	12.7	4.76	1	1.4	●	●															●		
	SPKN1204EDFR	12.7	12.7	4.76	1	1.4																			
	SPKN1204EDSKR	12.7	12.7	4.76	1	1.4							●												
	SPKN1504EDER	15.875	15.875	4.76	1	1.4																			
	SPKN1504EDEL	15.875	15.875	4.76	1	1.4																			
	SPKN1504EDFR	15.875	15.875	4.76	1	1.4																			
	SPKN1504EDFL (SPKN1504EDL)	15.875	15.875	4.76	1	1.4																			●
	SPKN1504EDSKR (SPKN1504EDR)	15.875	15.875	4.76	1	1.4	●						●			●	●						●		
	SPKN1504EDSKL (SPKN1504EDL)	15.875	15.875	4.76	1	1.4													○				●		
	SPKN1504EDTKR (SPKN1504EDR)	15.875	15.875	4.76	1	1.4									●	●									
	SPKN1504EDTKL	15.875	15.875	4.76	1	1.4																			
	SPKN1504EDS32PR (SPKN1504EDT32R)	15.875	15.875	4.76	1	1.4	○										●								
	SPKN1504EDS32PL (SPKN1504EDTL)	15.875	15.875	4.76	1	1.4																			
SPKN1504EDT32PR (SPKN1504EDTR)	15.875	15.875	4.76	1	1.4	●										○									
SPKN1504EDT32PL (SPKN1504EDTL)	15.875	15.875	4.76	1	1.4																				



● Ex Stock / ab Lager ○ On demand / auf Anfrage

SP*R

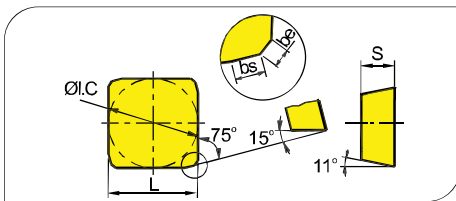

- Ideal Machining Condition / Gute Bearbeitungsbedingungen
- Normal Machining Condition / Normale Bearbeitungsbedingungen
- Unfavorable Machining Condition / Ungünstige Bearbeitungsbedingungen

Workpiece Material / Werkstoffe	P	M	K	N	S	CVD Coating / CVD Beschicht.								PVD Coating / PVD Beschicht.				Cermet / Cermet	Carbide uncoat. / unbe. Hartmetall					
	Steel / Stahl	Stainless Steel / Rostfreier Stahl	Cast iron / Gusseisen	Non-ferrite material / Ne Metalle	Heat-resistant steel / Warmfester Stahl	YBC301	YBC302	YBC401	YBM251	YBM253	YBM351	YBD152	YBD252	YBG102	YBG202	YBG205	YBG302	YBG152	YBG252	YNG151	YNG151C	YC30S	YD101	YD201
P	●					●	●	●	●	●	●	●	●	●	●	●	●	●	●	●	●	●	●	●
M		●						●	●	●					●	●	●				●	●	●	●
K			●									●	●	●							●	●	●	●
N				●																		●	●	●
S					●				●	●				●	●	●								

Insert WSP	Type Typ	Dimensions (mm) / Abmessungen					CVD Coating / CVD Beschicht.								PVD Coating / PVD Beschicht.				Cermet / Cermet	Carbide uncoat. / unbe. Hartmetall				
		L	I.C	S	be	bs	YBC301	YBC302	YBC401	YBM251	YBM253	YBM351	YBD152	YBD252	YBG102	YBG202	YBG205	YBG302	YBG152	YBG252	YNG151	YNG151C	YC30S	YD101
	SPKR1203EDR-GM	12.7	12.7	3.18	1	1.4				●						○								
	SPKR1203EDL-GM	12.7	12.7	3.18	1	1.4				●						○								
	SPKR1504EDR-GM	15.875	15.875	4.76	1	1.4				○						○								
	SPKR1504EDL-GM	15.875	15.875	4.76	1	1.4				○						○								
	SPKR1904EDFL	19.05	19.05	4.76	1	1.4																		
	SPKR1904EDFR	19.05	19.05	4.76	1	1.4																		

SP*W

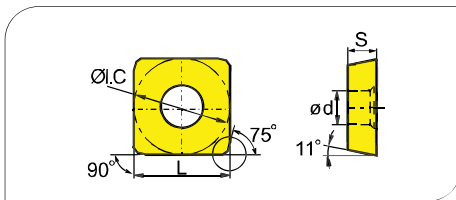

- Ideal Machining Condition / Gute Bearbeitungsbedingungen
- Normal Machining Condition / Normale Bearbeitungsbedingungen
- Unfavorable Machining Condition / Ungünstige Bearbeitungsbedingungen

Workpiece Material / Werkstoffe	P	M	K	N	S	CVD Coating / CVD Beschicht.								PVD Coating / PVD Beschicht.				Cermet / Cermet	Carbide uncoat. / unbe. Hartmetall					
	Steel / Stahl	Stainless Steel / Rostfreier Stahl	Cast iron / Gusseisen	Non-ferrite material / Ne Metalle	Heat-resistant steel / Warmfester Stahl	YBC301	YBC302	YBC401	YBM251	YBM253	YBM351	YBD152	YBD252	YBG102	YBG202	YBG205	YBG302	YBG152	YBG252	YNG151	YNG151C	YC30S	YD101	YD201
P	●					●	●	●	●	●	●	●	●	●	●	●	●	●	●	●	●	●	●	●
M		●						●	●	●					●	●	●				●	●	●	●
K			●									●	●	●							●	●	●	●
N				●																		●	●	●
S					●				●	●				●	●	●								

Insert WSP	Type Typ	Dimensions (mm) / Abmessungen						CVD Coating / CVD Beschicht.								PVD Coating / PVD Beschicht.				Cermet / Cermet	Carbide uncoat. / unbe. Hartmetall				
		r	L	I.C	S	d	α	YBC301	YBC302	YBC401	YBM251	YBM253	YBM351	YBD152	YBD252	YBG102	YBG202	YBG205	YBG302	YBG152	YBG252	YNG151	YNG151C	YC30S	YD101
	SPKW1204EDFR	---	12.7	12.7	4.76	5.56	11°										●								
	SPKW1204EDSR	---	12.7	12.7	4.76	5.56	11°										●								

Applicable tool / Werkzeug **B11-B18**

Tools code key / WSP ISO **B184-B185**

Grade selection guide / Sortenauswahl **B19-B23**

Technical data / Technische Daten **B215-B220**

Milling · Fräsen

Indexable Milling Tools · Wendeplattenfräser

SP*X

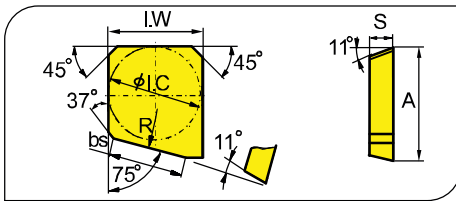

- Ideal Machining Condition / Gute Bearbeitungsbedingungen
- Normal Machining Condition / Normale Bearbeitungsbedingungen
- Unfavorable Machining Condition / Ungünstige Bearbeitungsbedingungen

Workpiece Material / Werkstoffe	P	M	K	N	S
P Steel / Stahl	●	●	●	●	●
M Stainless Steel / Rostfreier Stahl	●	●	●	●	●
K Cast iron / Gusseisen	●	●	●	●	●
N Non-ferrous material / <i>Ne Metalle</i>	●	●	●	●	●
S Heat-resistant steel / Warmfester Stahl	●	●	●	●	●

Insert WSP	Type Typ	Dimensions (mm) / Abmessungen						CVD Coating / CVD Beschicht.						PVD Coating / PVD Beschicht.				Cermet / Cermet	Carbide uncoat. / unbe. Hartmetall										
		A	I.C	I.W	S	bs	R	YBC301	YBC302	YBC401	YBM251	YBM253	YBM351	YBD152	YBD252	YBG102	YBG202		YBG205	YBG302	YBG152	YBG252	YNG151	YNG151C	YC30S	YD101	YD201		
	SPEX1203EDL-1	15	12.7	12.7	3.18	10	500																					○	
	SPEX1203EDR-1	15	12.7	12.7	3.18	10	500																					●	
	SPEX1504EDL-1	18.2	15.875	15.875	4.76	10	500																						●
	SPEX1504EDR-1	18.2	15.875	15.875	4.76	10	500																						●

● Ex Stock / ab Lager ○ On demand / auf Anfrage

Milling · Fräsen

Indexable Milling Tools · Wendeplattenfräser

SP**

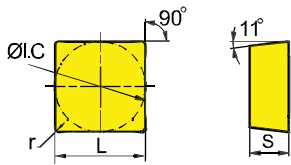

- Ideal Machining Condition / Gute Bearbeitungsbedingungen
- Normal Machining Condition / Normale Bearbeitungsbedingungen
- Unfavorable Machining Condition / Ungünstige Bearbeitungsbedingungen

Workpiece Material / Werkstoffe	CVD Coating / CVD Beschicht.												PVD Coating / PVD Beschicht.		Cermet / Cermet	Carbide uncoat. / unbe. Hartmetall									
	P	M	K	N	S	YBC301	YBC302	YBC401	YBM251	YBM253	YBM351	YBD152	YBD252	YBG102		YBG202	YBG205	YBG302	YBG152	YBG252	YNG151	YNG151C	YC30S	YD101	YD201
P Steel / Stahl	●	●	●	●	●	●	●	●	●	●	●	●	●	●	●	●	●	●	●	●	●	●	●	●	●
M Stainless Steel / Rostfreier Stahl			●	●	●													●	●	●	●	●	●	●	●
K Cast iron / Gusseisen											●	●	●					●	●	●	●	●	●	●	●
N Non-ferrite material / Ne Metalle																							●	●	●
S Heat-resistant steel / Warmfester Stahl									●	●				●	●	●									

Insert WSP	Type Typ	Dimensions (mm) / Abmessungen				CVD Coating / CVD Beschicht.								PVD Coating / PVD Beschicht.					Cermet / Cermet	Carbide uncoat. / unbe. Hartmetall					
		L	I.C	s	r	YBC301	YBC302	YBC401	YBM251	YBM253	YBM351	YBD152	YBD252	YBG102	YBG202	YBG205	YBG302	YBG152		YBG252	YNG151	YNG151C	YC30S	YD101	YD201
	SPUN090304	9.525	9.525	3.18	0.4																		●		
	SPUN090308	9.525	9.525	3.18	0.8																		●		
	SPUN120304	12.7	12.7	3.18	0.4																		●		
	SPUN120308	12.7	12.7	3.18	0.8				●		○												●		○
	SPUN120312	12.7	12.7	3.18	1.2				●														●		○
	SPUN150408	15.875	15.875	4.76	0.8																		●		○
	SPUN150412	15.875	15.875	4.76	1.2																		●		○
	SPUN190408	19.05	19.05	4.76	0.8																		●		
	SPUN190412	19.05	19.05	4.76	1.2																		○		
	SPUN190416	19.05	19.05	4.76	1.6																				
	SPGN090304	9.525	9.525	3.18	0.4																	●			
	SPGN090308	9.525	9.525	3.18	0.8																		○		
	SPGN120304	12.7	12.7	3.18	0.4																		●		
	SPGN120308	12.7	12.7	3.18	0.8											●							●		
	SPGN120404	12.7	12.7	4.76	0.4																				
	SPGN120408	12.7	12.7	4.76	0.8																				
	SPGN120412	12.7	12.7	4.76	1.2																				
	SPGN150404	15.875	15.875	4.76	0.4																				
	SPGN150408	15.875	15.875	4.76	0.8																		●		
	SPGN150412	15.875	15.875	4.76	1.2																		○		
	SPGN190408	19.05	19.05	4.76	0.8																		○		
SPGN190416	19.05	19.05	4.76	1.6																					

● Ex Stock / ab Lager ○ On demand / auf Anfrage

TP**

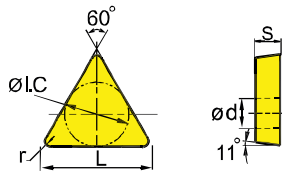

- Ideal Machining Condition / Gute Bearbeitungsbedingungen
- Normal Machining Condition / Normale Bearbeitungsbedingungen
- Unfavorable Machining Condition / Ungünstige Bearbeitungsbedingungen

Workpiece Material Werkstoffe	CVD Coating												PVD Coating		Cermets Cemet	Carbide uncoat. unbe. Hartmetall									
	P	M	K	N	S	YBC301	YBC302	YBC401	YBM251	YBM253	YBM351	YBD152	YBD252	YBG102		YBG202	YBG205	YBG302	YBG152	YBG252	YNG151	YNG151C	YC30S	YD101	YD201
P Steel Stahl	●	●	●	●	●	●	●	●	●	●	●	●	●	●	●	●	●	●	●	●	●	●	●	●	●
M Stainless Steel Rostfreier Stahl		●	●	●	●										●	●	●	●	●	●	●	●	●	●	●
K Cast iron Gusseisen																									●
N Non-ferrous material Ne Metalle																									●
S Heat-resistant steel Wärmeester Stahl															●	●	●	●	●	●	●	●	●	●	●

Insert WSP	Type Typ	Dimensions (mm) Abmessungen						S	CVD Coating CVD Beschicht.						PVD Coating PVD Beschicht.						Cermets Cemet	Carbide uncoat. unbe. Hartmetall					
		L	I.C.	bs	be	an	S		YBC301	YBC302	YBC401	YBM251	YBM253	YBM351	YBD152	YBD252	YBG102	YBG202	YBG205	YBG302		YBG152	YBG252	YNG151	YNG151C	YC30S	YD101
	TPCN1103PPS22PN (TPCN1103PP)	11	6.35	0.7	0.7	11°	3.18																			●	
	TPCN1603PPS42PN (TPCN1603PP)	16.5	9.525	1.2	1.2	11°	3.18	○										○								○	
	TPCN2204PDR	22	12.7	1.4	1.4	15°	4.76																			○	
	TPCN2204PDR (TPCN2204PDR)	22	12.7	1.4	1.4	15°	4.76	●																		●	
	TPCN2204PPN (TPCN2204PPN)	22	12.7	1.4	1.4	11°	4.76	○																			
	TPAN1103PPS22PN (TPAN1103PP)	11	6.35	0.7	0.7	11°	3.18	○									○								○		
	TPAN1603PPS42PN (TPAN1603PP)	16.5	9.525	1.2	1.2	11°	3.18	○									○								○		
	TPAN2204PDR (TPAN2204PDR)	22	12.7	1.4	1.4	15°	4.76																		○		
	TPAN2204PDR	22	12.7	1.4	1.4	11°	4.76																			○	

B

Milling Tools
Fräser

Applicable tool B11-B18
Werkzeug

Tools code key B184-B185
WSP ISO

Grade selection guide B19-B23
Sortenauswahl

Technical data B215-B220
Technische Daten

Milling · Fräsen

Indexable Milling Tools · Wendeplattenfräser

TP**

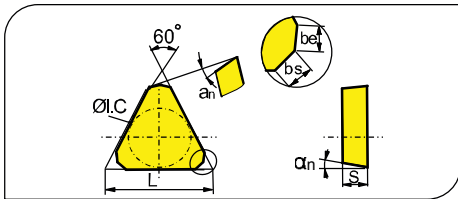

- Ideal Machining Condition / Gute Bearbeitungsbedingungen
- Normal Machining Condition / Normale Bearbeitungsbedingungen
- Unfavorable Machining Condition / Ungünstige Bearbeitungsbedingungen

Workpiece Material / Werkstoffe	P	M	K	N	S
P Steel / Stahl	●	●	●	●	●
M Stainless Steel / Rostfreier Stahl	●	●	●	●	●
K Cast iron / Gusseisen	●	●	●	●	●
N Non-ferrous material / Ne Metalle	●	●	●	●	●
S Heat-resistant steel / Warmfester Stahl	●	●	●	●	●

Insert WSP	Type Typ	Dimensions (mm) / Abmessungen						CVD Coating / CVD Beschicht.						PVD Coating / PVD Beschicht.						Cermet Cermet	Carbide uncoat. / unbe. Hartmetall					
		L	I.C	S	be	bs	an	YBC301	YBC302	YBC401	YBM251	YBM253	YBM351	YBD152	YBD252	YBG102	YBG202	YBG205	YBG302		YBG152	YBG252	YNG151	YNG151C	YC30S	YD101
	TPKN1603PDSKR (TPKN1603PDR)	16.5	9.525	3.18	1.2	1	15°	●	○							○	●	○						●	○	
	TPKN1603PDSKL (TPKN1603PDL)	16.5	9.525	3.18	1.2	1	11°																			
	TPKN1603PPER (TPKN1603PPR)	16.5	9.525	3.18	1.2	1	11°	●	○															●		
	TPKN1603PPFR (TPKN1603PPR)	22	12.7	4.76	1.4	0.7	11°										○								●	
	TPKN2204PDTKR	22	12.7	4.76	1.4	0.7	11°										●									
	TPKN2204PDFR	22	12.7	4.76	1.4	0.7	11°																		●	
	TPKN2204PDFL	22	12.7	4.76	1.4	0.7	11°																			○
	TPKN2204PDSKR (TPKN2204PDR)	22	12.7	4.76	1.4	0.7	11°	●	●			●					●	●	●					○		
	TPKN2204PDL	22	12.7	4.76	1.4	0.7	11°	●																●	●	
	TPKN2204PDTR	22	12.7	4.76	1.4	0.7	11°	○									○							●		

(old Materialnr. / alte Artikelnr.)

● Ex Stock / ab Lager ○ On demand / auf Anfrage

Milling - Fräsen

Indexable Milling Tools - Wendepplattenfräser

WP**

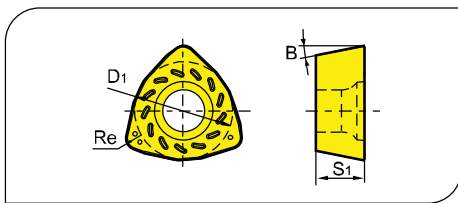

- Ideal Machining Condition / Gute Bearbeitungsbedingungen
- Normal Machining Condition / Normale Bearbeitungsbedingungen
- Unfavorable Machining Condition / Ungünstige Bearbeitungsbedingungen

Workpiece Material / Werkstoffe	P	M	K	N	S
Steel / Stahl	●	●	●	●	●
Stainless Steel / Rostfreier Stahl	●	●	●	●	●
Cast iron / Gusseisen	●	●	●	●	●
Non-ferrous material / Ne Metalle	●	●	●	●	●
Heat-resistant steel / Warmfester Stahl	●	●	●	●	●

Insert WSP	Type Typ	Dimensions (mm) / Abmessungen				CVD Coating / CVD Beschicht.				PVD Coating / PVD Beschicht.				Cermet / Cermet	Carbide uncoat. / unbe. Hartmetall											
		B	Re	S ₁	D ₁	YBC301	YBC302	YBC401	YBM251	YBM253	YBM351	YBD152	YBD252		YBG102	YBG202	YBG205	YBG302	YBG152	YBG252	YNG151	YNG151C	YC30S	YD101	YD201	
	WPGT050315ZSR	11°	1.5	3.5	7.94	●					●															
	WPGT060415ZSR	11°	1.5	4.2	9.525	●					●															
	WPGT080615ZSR	11°	1.5	6.35	12.85	●					●															
	WPGT090725ZSR	11°	2.5	7	15	●					●															
	WPGT050315ZSR-PM	11°	1.5	3.5	7.94	●					○															
	WPGT060415ZSR-PM	11°	1.5	4.2	9.525	●					○															
	WPGT080615ZSR-PM	11°	1.5	6.35	12.85	●					○															
	WPGT090725ZSR-PM	11°	2.5	7	15	●					○															

XP**

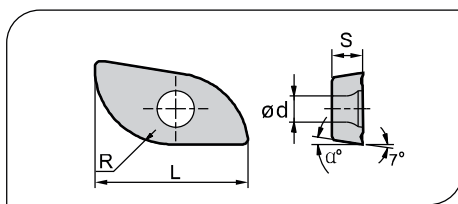

- Ideal Machining Condition / Gute Bearbeitungsbedingungen
- Normal Machining Condition / Normale Bearbeitungsbedingungen
- Unfavorable Machining Condition / Ungünstige Bearbeitungsbedingungen

Workpiece Material / Werkstoffe	P	M	K	N	S
Steel / Stahl	●	●	●	●	●
Stainless Steel / Rostfreier Stahl	●	●	●	●	●
Cast iron / Gusseisen	●	●	●	●	●
Non-ferrous material / Ne Metalle	●	●	●	●	●
Heat-resistant steel / Warmfester Stahl	●	●	●	●	●

Insert WSP	Type Typ	Dimensions (mm) / Abmessungen					CVD Coating / CVD Beschicht.				PVD Coating / PVD Beschicht.				Cermet / Cermet	Carbide uncoat. / unbe. Hartmetall											
		R	d	S	α°	L	YBC301	YBC302	YBC401	YBM251	YBM253	YBM351	YBD152	YBD252		YBG102	YBG202	YBG205	YBG302	YBG152	YBG252	YNG151	YNG151C	YC30S	YD101	YD201	
	XPHT16R0803-GM	8	3.1	3.18	9	16																					
	XPHT20R10T3-GM	10	4.0	3.97	9	20																					
	XPHT25R1204-GM	12.5	4.7	4.76	9	25																					
	XPHT30R1506-GM	15	5.8	6.35	11	30																					
	XPHT32R1606-GM	16	5.8	6.35	9	32																					
	XPHT40R2007-GM	20	6.8	7.94	9	40																					
	XPHT50R2507-GM	25	9.2	7.94	9	50																					

● Ex Stock / ab Lager ○ On demand / auf Anfrage

XS**

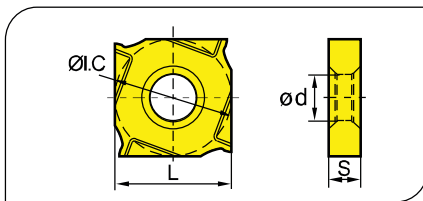

- Ideal Machining Condition / Gute Bearbeitungsbedingungen
- ⊗ Normal Machining Condition / Normale Bearbeitungsbedingungen
- ⊗ Unfavorable Machining Condition / Ungünstige Bearbeitungsbedingungen

Workpiece Material / Werkstoffe	P Steel / Stahl	M Stainless Steel / Rostfreier Stahl	K Cast iron / Gusseisen	N Non-ferrite material / Ne Metalle	S Heat-resistant steel / Warmfester Stahl
YBC301	●	●	●	●	●
YBC302	●	●	●	●	●
YBC401	●	●	●	●	●
YBM251	●	●	●	●	●
YBM253	●	●	●	●	●
YBM351	●	●	●	●	●
YBD152	●	●	●	●	●
YBD252	●	●	●	●	●
YBG102	●	●	●	●	●
YBG202	●	●	●	●	●
YBG205	●	●	●	●	●
YBG302	●	●	●	●	●
YBG152	●	●	●	●	●
YBG252	●	●	●	●	●
YNG151	●	●	●	●	●
YNG151C	●	●	●	●	●
YC30S	●	●	●	●	●
YD101	●	●	●	●	●
YD201	●	●	●	●	●

Insert WSP	Type Typ	Dimensions (mm) / Abmessungen				CVD Coating / CVD Beschicht.					PVD Coating / PVD Beschicht.					Cermet / Cermet	Carbide uncoat. / unbe. Hartmetall									
		I.C	L	S	d	YBC301	YBC302	YBC401	YBM251	YBM253	YBM351	YBD152	YBD252	YBG102	YBG202		YBG205	YBG302	YBG152	YBG252	YNG151	YNG151C	YC30S	YD101	YD201	
	XSEQ1202	12.7	12.7	2.3	5.0																					
	XSEQ1203	12.7	12.7	3.0	5.0		●			●								●								
	XSEQ12T3	12.7	12.7	3.5	5.0	●												●							○	
	XSEQ1204	12.7	12.7	4.0	5.0														●							
	XSEQ12T4	12.7	12.7	4.5	5.0														●							

ZD**

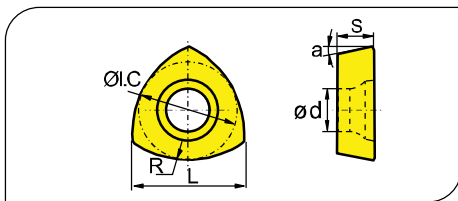

- Ideal Machining Condition / Gute Bearbeitungsbedingungen
- ⊗ Normal Machining Condition / Normale Bearbeitungsbedingungen
- ⊗ Unfavorable Machining Condition / Ungünstige Bearbeitungsbedingungen

Workpiece Material / Werkstoffe	P Steel / Stahl	M Stainless Steel / Rostfreier Stahl	K Cast iron / Gusseisen	N Non-ferrite material / Ne Metalle	S Heat-resistant steel / Warmfester Stahl
YBC301	●	●	●	●	●
YBC302	●	●	●	●	●
YBC401	●	●	●	●	●
YBM251	●	●	●	●	●
YBM253	●	●	●	●	●
YBM351	●	●	●	●	●
YBD152	●	●	●	●	●
YBD252	●	●	●	●	●
YBG102	●	●	●	●	●
YBG202	●	●	●	●	●
YBG205	●	●	●	●	●
YBG302	●	●	●	●	●
YBG152	●	●	●	●	●
YBG252	●	●	●	●	●
YNG151	●	●	●	●	●
YNG151C	●	●	●	●	●
YC30S	●	●	●	●	●
YD101	●	●	●	●	●
YD201	●	●	●	●	●

Insert WSP	Type Typ	Dimensions (mm) / Abmessungen						CVD Coating / CVD Beschicht.					PVD Coating / PVD Beschicht.					Cermet / Cermet	Carbide uncoat. / unbe. Hartmetall								
		I.C	L	S	R	d	α	YBC301	YBC302	YBC401	YBM251	YBM253	YBM351	YBD152	YBD252	YBG102	YBG202		YBG205	YBG302	YBG152	YBG252	YNG151	YNG151C	YC30S	YD101	YD201
	ZDET08T2CYR10	6.75	8.4	2.78	10	2.8	14°				●																
	ZDET1103CYR12.5	8.5	10.6	3.18	12.5	2.8	14°				●																
	ZDET13T3CYR16	10.5	13.2	3.97	16	4.4	14°																				
	ZDET13T3CYR16-PM	10.5	13.2	3.97	16	4.4	14°				●							●									

Milling - Fräsen

Indexable Milling Tools - Wendepplattenfräser

ZP**

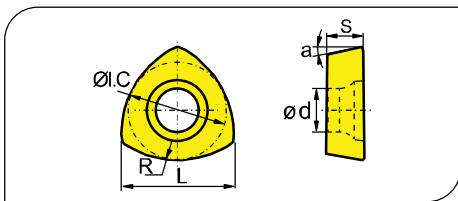

- Ideal Machining Condition / Gute Bearbeitungsbedingungen
- Normal Machining Condition / Normale Bearbeitungsbedingungen
- Unfavorable Machining Condition / Ungünstige Bearbeitungsbedingungen

Workpiece Material / Werkstoffe	CVD Coating / CVD Beschicht.							PVD Coating / PVD Beschicht.					Cermet / Cermet	Carbide uncoat. / unbe. Hartmetall											
	P	M	K	N	S	YBC301	YBC302	YBC401	YBM251	YBM253	YBM351	YBD152		YBD252	YBG102	YBG202	YBG205	YBG302	YBG152	YBG252	YNG151	YNG151C	YC30S	YD101	YD201
P Steel / Stahl	●	●	●	●	●	●	●	●	●	●	●	●	●	●	●	●	●	●	●	●	●	●	●	●	●
M Stainless Steel / Rostfreier Stahl		●	●	●	●	●	●	●	●	●	●	●	●	●	●	●	●	●	●	●	●	●	●	●	●
K Cast iron / Gusseisen											●	●	●	●	●	●	●	●	●	●	●	●	●	●	●
N Non-ferrite material / Ne Metalle																							●	●	●
S Heat-resistant steel / Warmfester Stahl											●	●	●	●	●	●	●	●	●	●	●	●	●	●	●

Insert WSP	Type Typ	Dimensions (mm) / Abmessungen						CVD Coating / CVD Beschicht.						PVD Coating / PVD Beschicht.					Cermet / Cermet	Carbide uncoat. / unbe. Hartmetall						
		I.C	L	S	R	d	α	YBC301	YBC302	YBC401	YBM251	YBM253	YBM351	YBD152	YBD252	YBG102	YBG202	YBG205		YBG302	YBG152	YBG252	YNG151	YNG151C	YC30S	YD101
	ZPNT2204CY(R20)	12.7	16.1	4.76	20	5.56	11°				○															
	ZPNT2204CY(R25)	12.7	16.9	4.76	25	5.56	11°				●															
	ZPNT2204CY(R31)	12.7	17.6	4.76	31.5	5.56	11°				●															

ZO**

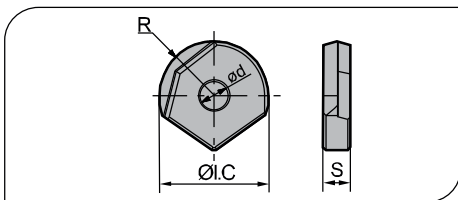

- Ideal Machining Condition / Gute Bearbeitungsbedingungen
- Normal Machining Condition / Normale Bearbeitungsbedingungen
- Unfavorable Machining Condition / Ungünstige Bearbeitungsbedingungen

Workpiece Material / Werkstoffe	CVD Coating / CVD Beschicht.							PVD Coating / PVD Beschicht.					Cermet / Cermet	Carbide uncoat. / unbe. Hartmetall											
	P	M	K	N	S	YBC301	YBC302	YBC401	YBM251	YBM253	YBM351	YBD152		YBD252	YBG102	YBG202	YBG205	YBG302	YBG152	YBG252	YNG151	YNG151C	YC30S	YD101	YD201
P Steel / Stahl	●	●	●	●	●	●	●	●	●	●	●	●	●	●	●	●	●	●	●	●	●	●	●	●	●
M Stainless Steel / Rostfreier Stahl		●	●	●	●	●	●	●	●	●	●	●	●	●	●	●	●	●	●	●	●	●	●	●	●
K Cast iron / Gusseisen											●	●	●	●	●	●	●	●	●	●	●	●	●	●	●
N Non-ferrite material / Ne Metalle																							●	●	●
S Heat-resistant steel / Warmfester Stahl											●	●	●	●	●	●	●	●	●	●	●	●	●	●	●

Insert WSP	Type Typ	Dimensions (mm) / Abmessungen				CVD Coating / CVD Beschicht.						PVD Coating / PVD Beschicht.					Cermet / Cermet	Carbide uncoat. / unbe. Hartmetall								
		R	I.C	S	d	YBC301	YBC302	YBC401	YBM251	YBM253	YBM351	YBD152	YBD252	YBG102	YBG202	YBG205		YBG302	YBG152	YBG252	YNG151	YNG151C	YC30S	YD101	YD201	
	ZOHX1203-GF	6	12	3	4															●						
	ZOHX1604-GF	8	16	4	5															●						
	ZOHX2005-GF	10	20	5	5															●						
	ZOHX2506-GF	12.5	25	6	6															○						
	ZOHX3007-GF	15	30	7	8															●						
	ZOHX3207-GF	16	32	7	8															●						
	ZOHX1203-GM	6	12	3	4															●						
	ZOHX1604-GM	8	16	4	5															●						
	ZOHX2005-GM	10	20	5	5															●						
	ZOHX2506-GM	12.5	25	6	6															○						
	ZOHX3007-GM	15	30	7	8															●						
	ZOHX3207-GM	16	32	7	8															●						

● Ex Stock / ab Lager ○ On demand / auf Anfrage

Difference and selection between down milling and up milling Unterschied zwischen Gleichlauf- und Gegenlauf

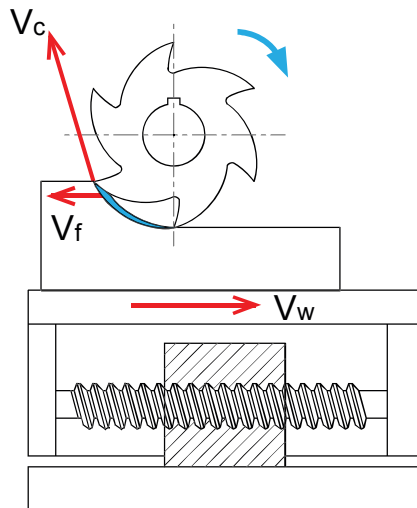

**Up milling
Gegenlaufräsen**

Up milling (conventional milling): the feed direction of workpiece is opposite to that of the milling rotation at the connecting position.

Beim Gegenlaufräsen ist die Drehrichtung des Fräswerkzeugs und die Vorschubrichtung des Werkstücks entgegengesetzt.

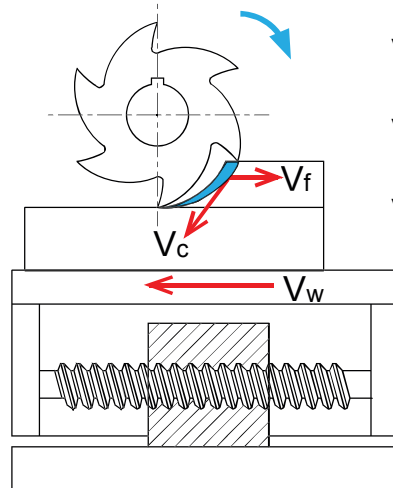

**Down milling
Gleichlaufräsen**

Down milling (climb milling): the feed direction of workpiece is the same as that of the milling rotation at the connecting position.

Beim Gleichlaufräsen sind die Drehrichtung des Fräswerkzeugs und die Vorschubrichtung des Werkstücks gleich gerichtet.

V_c = Cutting Speed
Schnittgeschwindigkeit

V_f = Feedrate tool
Vorschub Werkzeug



V_w = Feedrate Workpiece
Vorschub Werkstück

Advantage and Disadvantage · Vor- und Nachteile :

Direction Richtung	Advantage Vorteil	Disadvantage Nachteil
Up milling Gegenlaufräsen	Prevent hooking of tool, more smooth cut Verhindert das Einhaken des Werkzeugs, ruhigerer Lauf	Bigger stress on cutting edge, tool life shorter Größere Belastung für den Schneidstoff, kürzere Standzeiten
Down milling Gleichlaufräsen	Higher tool life, less thermal stress Höhere Standzeiten, weniger thermische Belastung	Hooking of tool possible Einhaken des Werkzeugs möglich

Pitch selection · Fräserteilung

Pitch is the distance between one point on one cutting edge and the same point on the next edge. **Milling cutters are mainly classified into coarse, fine and extra fine pitches.** Als Fräserteilung wird der Abstand von einer Schneidenecke zur nächsten Schneidenecke bezeichnet. Die Einteilung erfolgt in weite (differential), enge und extra enge Teilung.

Operational stability · Bearbeitungsstabilität		
L (Low / Niedrig)	M (Medium / Mittel)	H (High / Hoch)
<p>Coarse pitch · weite Teilung</p>  <p>(Differential Pech)</p>	<p>Fine pitch · Enge Teilung</p> 	<p>Extra fine pitch Extra Enge Teilung</p> 
<p>When the milling width equal to diameter of cutter, the machining system is stable and main power of machine is sufficient, selecting coarse pitch can achieve high productive efficiency.</p> <p>Ist die Fräsbreite gleich dem Fräserdurchmesser, die Maschinen in sich stabil, und mit genügend Leistung, wird eine weite Teilung verwendet, um eine hohe Produktivität zu erreichen.</p>	<p>General milling function and multiple mixed productions</p> <p>Erste Wahl für allgemeine Fräsbearbeitung und Mischbearbeitung</p>	<p>When the milling width is less than diameter of cutter, cutting by maximum edges can achieve high productive efficiency.</p> <p>Ist die Fräsbreite kleiner als der Fräserdurchmesser, ermöglicht eine große Schneidanzahl eine hohe Produktivität. Für alle Materialien geeignet, besonders auch bei hochwarmfesten Werkstoffen.</p>

Selection of approach angle · Einstellwinkel

The approach angle is composed by insert and tool body, Chip thickness, cutting forces and tool-life are affected especially by the approach angle. Decreasing the approach angle reduces chip thickness and spreads the cutting area between cutting edge and workpiece for a given feed rate.

A smaller approach angle also guarantee that it is stable entering into or exiting workpiece, to protect the cutting edge and extend tool life. However this will increase higher axial cutting forces on the workpiece, thus is not suitable for machining thin workpiece such as thin plate.

Approach angle	Feed rate per tooth Zahnvorschub	Real max. cutting depth Max. Spandicke
90°	f_z	$h_{ex} = f_z \times \sin \alpha$
75°	f_z	$h_{ex} = 0.96 \times f_z$
60°	f_z	$h_{ex} = 0.86 \times f_z$
45°	f_z	$h_{ex} = 0.707 \times f_z$
Round insert	f_z	$h_{ex} = \frac{\sqrt{iC^2 \times (iC - 2ap)^2}}{iC} \times f_z$

Der Einstellwinkel eines Planfräasers steht in Verbindung mit der Spandicke. Dies ist der Winkel zwischen der Hauptschneide der Wendschneidplatte und der Werkstückoberfläche. Spandicke, Schnittkräfte und Standzeit werden insbesondere durch den Einstellwinkel beeinflusst. Durch Verringern des Einstellwinkels wird die Spandicke bei einer gegebenen Vorschubrate kleiner. Dieser Effekt führt dazu, dass sich die Werkstückstoffmenge über einen größeren Teil der Schneidkante verteilt. Ein kleiner Einstellwinkel sorgt auch für einen weniger abrupten Eintritt in den Schnitt, wodurch der radiale Druck sinkt und die Schneidkante geschont wird. Die höheren axialen Kräfte verstärken jedoch den Druck auf das Werkstück. Für die Bearbeitung von dünnwandigen Bauteilen nicht geeignet.

General formula · Allgemeine Formeln

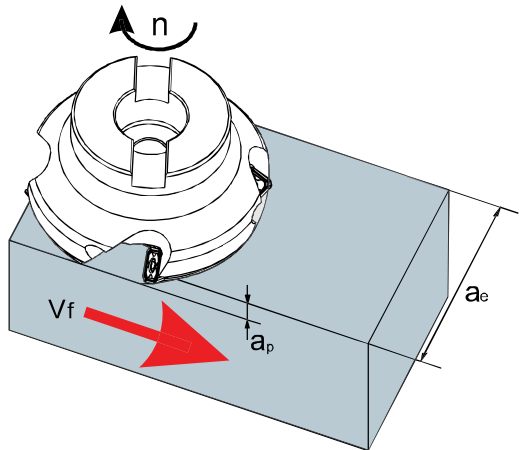
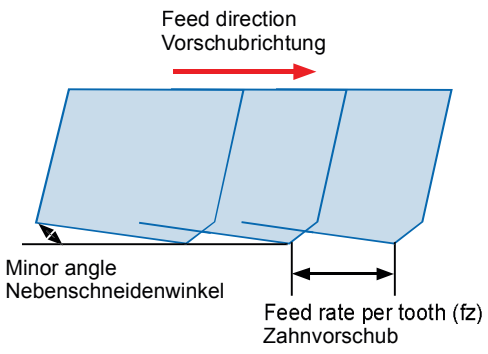
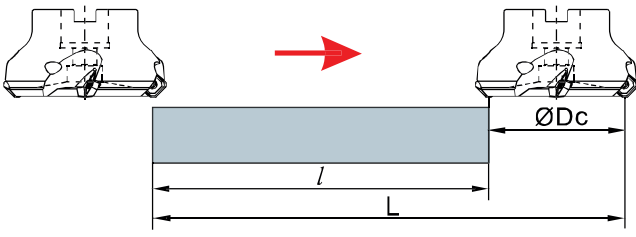
<p>V_c : cutting speed (m/min) Schnittgeschwindigkeit (m/min)</p> <p>D_c : nominal diameter of milling tool (mm) Sollmaß von Fräswerkzeugen (mm)</p> <p>n : spindle speed (rev/min) Umdrehungsgeschwindigkeit (u/min)</p> <p>z_n : number of teeth Zähne Anzahl</p> <p>Q : metal removal rate (cm³/min) Material Abtragungsrate (cm³/min)</p>	<p>V_f : feed rate of worktable (feed speed) (mm/min) Vorschub Maschinentisch (feed speed) (mm/min)</p> <p>f_z : feed rate per tooth (mm/z) Zahnvorschub (mm/z)</p> <p>π : circumference ratio≈3.14 Kreiszahl ~3,4</p> <p>T_c : machining time (min) Bearbeitungszeit (min)</p> <p>f_n : feed rate per revolution (mm/rev) Vorschub pro Umdrehung (mm/u)</p>
<p>● Cutting speed · Schnittgeschwindigkeit</p> $V_c = \frac{\pi \times D_c \times n}{1000} \text{ (m/min)}$	  
<p>● Spindle speed · Umdrehungsgeschwindigkeit</p> $n = \frac{1000 \times V_c}{\pi \times D_c} \text{ (rev/min)}$	
<p>● Feed rate of worktable (feed speed)</p> <p>● Vorschub des Maschinentisches</p> $V_f = f_z \times n \times z_n \text{ (mm/min)}$	
<p>● Feed rate per tooth · Zahnvorschub</p> $f_z = \frac{V_f}{n \times z_n} \text{ (mm/z)}$	
<p>● Feed rate per revolution · Vorschub pro Umdrehung</p> $f_n = \frac{V_f}{n} \text{ (mm/rev)}$	
<p>● Machining time · Bearbeitungszeit</p> $T_c = \frac{1000 \times V_c}{\pi \times D_c} \text{ (min)}$	
<p>● Metal removal rate · Zerspanungsvolumen</p> $Q = \frac{a_p \times a_e \times V_f}{1000} \text{ (cm}^3\text{/min)}$	

Function of each part in face milling · Winkelfunktion beim Planfräsen

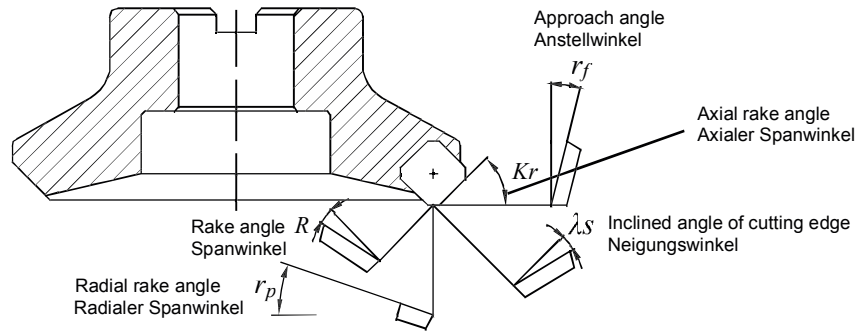

Main angles of face mills · Winkel beim Planfräsen

Designation Winkel	Function Funktion	Effect Auswirkung		
Axial rake angle Axialer Spanwinkel r_f	Determining the chip direction Beeinflusst die Spanflußrichtung	negative angle, excellent chip removal Negativer <Spanwinkel, gute Späneabfuhr		
Radial rake angle Radialer Spanwinkel r_p	Determining sharpness of cutting edge Definiert die Schneidenschärfe	Positive angle, good cutting performance Positive Winkel, gute Schnittleistung		
Approach angle Anstellwinkel Kr	Determining the chip thickness Beeinflusst die Spandicke	$Kr \uparrow$, chip thickness \uparrow , $Kr \downarrow$, chip thickness \downarrow ; $Kr \uparrow$, Spandicke \uparrow , $Kr \downarrow$, Spandicke \downarrow ;		
Rake angle Spanwinkel R	Determining true sharpness of cutting edge Beeinflusst die wahre Plattenschärfe	Poor cutting performance, high strength of cutting edge Schlechte Schnittleistung, starke Schneidkante	(-) \leftarrow 0 \rightarrow (+)	Good cutting performance, low strength of cutting edge Schlechte Schnittleistung, starke Schneidkante
Inclined angle of cutting edge Neigungswinkel λ_s	Determining the chip flow direction Beeinflusst die Spanflußrichtung	Poor cutting performance, high strength of cutting edge Gute Schnittleistung, schwächere Schneidkante	(-) \leftarrow 0 \rightarrow (+)	Good cutting performance, low strength of cutting edge Gute Schnittleistung, schwächere Schneidkante

Combination of different rake angles · Kombination von verschiedenen Spanwinkeln

		Double positive Doppelt Positiv	Double negative Doppelt Negativ	One pos., one neg. Positiv / Negativ
Negative rake angle Negativer Spanwinkel				
0° rake angle Neutraler Winkel				
Positive rake angle Positiver Spanwinkel				
Axial rake angle r_f / axialer Spanwinkel		+	-	+
Radial rake angle r_p / radialer Spanwinkel		+	-	-
Applicable material machined Anwendungsbereich	P	✓		✓
	M	✓		✓
	K		✓	✓
	N	✓		
	S	✓		✓

Cutting performances of different approach angles Schneidleistung bei verschiedenen Anstellwinkeln

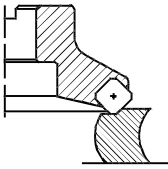
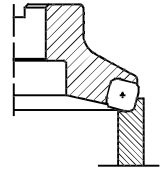
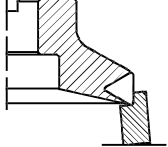
Approach angle Anstellwinkel	Schematic diagram Darstellung	Instruction Erklärung
45°		<p>Axial force is largest. It will bend when machining thin-wall workpiece, and reduces the precision of workpiece. It is benefit to avoid fringe breakage of workpiece when machining cast iron</p> <p>Die axiale Kraft ist sehr hoch. Wegen der Verbiegung nicht geeignet für die Bearbeitung von dünnwandigen Bauteilen. Optimal für die Planbearbeitung von Stahl, Guss und rostfreien Materialien.</p>
75°		<p>The main purpose is to resolve the radial cutting force, it is often used for general face milling.</p> <p>Zur Reduzierung der radialen Kräfte. Für die allgemeine Planbearbeitung.</p>
90°		<p>The axial force is zero in theory, suitable for milling thin plate workpiece.</p> <p>Die axiale Kraft ist nahezu null. Für die Zerspaltung von dünnen, labilen Werkstücken geeignet.</p>

Wiper insert · Wiper Platte

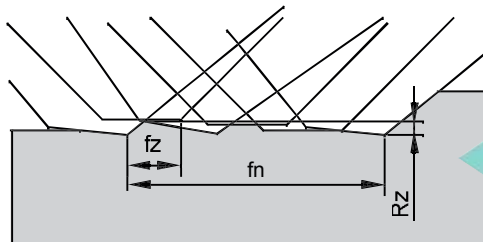

Required Surface roughness with common insert isn't good.

Geforderte Oberflächengüte mit herkömmlichen Platten wird nicht erreicht.

Solution · Lösung

Assembling wiper inserts
Einsatz von Wiper Platten

usage · Anwendung

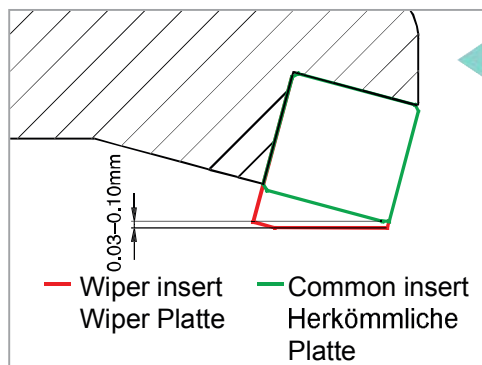

The wiper insert must protrude below the other inserts by 0.03-0.10 mm at axial direction, only that the wiping function can take into effect.

Generally speaking, a cutter can just assemble only one wiper insert. If the diameter of cutter is much bigger or cutter's feed rate per revolution is bigger than the length of wiper edge, 2 to 3 wiper inserts can be assembled.

Die Wiperplatte muss ca. 0,03 – 0,1 mm über den normalen Platten in axialer Richtung stehen, um den Wipereffekt zu erreichen.

Bei Standarddurchmessern reicht eine Wiperplatte.
Bei sehr großen Fräserdurchmessern oder großen Vorschubraten können bis zu 3 Wiperplatten eingesetzt werden.

Selection of cutting width and tool cutting diameter in face milling

Schnittbreiten - Auswahl und Werkzeug - Durchmesser beim Planfräsen

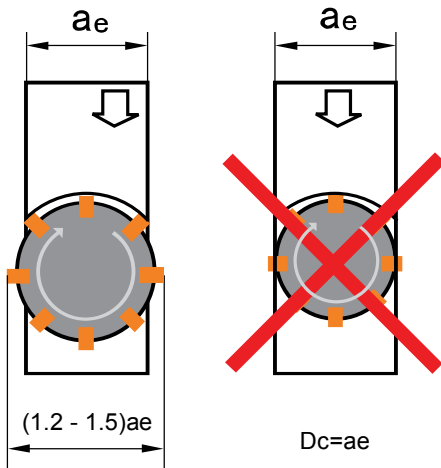

Generally speaking, the relation between cutting width and tool cutting diameter is $D_c = (1.2 - 1.5) a_e$. In the machining practice, it need to avoid coincidence of tool center and workpiece center as much as possible.

In der allgemeinen Anwendung sollte der Fräserdurchmesser 1.2 – 1,5 mal a_e betragen.
Positionieren Sie den Fräser leicht außermittig.

D_c : Diameter of milling tool · Werkzeugdurchmesser

a_e : Cutting width · Seitliche Zustellung

Threading pre-hole diameter · Kernlochdurchmesser

- Metric Coarse thread
- Metrisch - Gewinde

- Metric fine screw fine
- Metrisch - Feingewinde

Thread code Gewindebez.	Pre-hole diameter (mm) Kerndurchmesser	Thread code Gewindebez.	Pre-hole diameter (mm) Kerndurchmesser	Thread code Gewindebez.	Pre-hole diameter (mm) Kerndurchmesser
M3×0.5	2.5	M3×0.35	2.65	M14×1.5	12.5
M3.5×0.6	2.9	M3.5×0.35	3.15	M14×1.0	13.0
M4×0.7	3.3	M4×0.5	3.5	M15×1.5	13.5
M5×0.8	4.2	M4.5×0.5	4.0	M15×1.0	14.0
M6×1.0	5.0	M5×0.5	4.5	M16×1.5	14.5
M7×1.0	6.0	M5.5×0.5	5.0	M16×1.0	15.0
M8×1.25	6.75	M6×0.75	5.25	M17×1.5	15.5
M9×1.25	7.75	M7×0.75	6.25	M17×1.0	16.0
M10×1.5	8.5	M8×1.0	7.0	M18×2.0	16.0
M11×1.5	9.5	M8×0.75	7.25	M18×1.5	16.5
M12×1.75	10.25	M9×1.0	8.0	M18×1.0	17.0
M14×2.0	12.0	M9×0.75	8.25	M20×2.0	18.0
M16×2.0	14.0	M10×1.25	8.75	M20×1.5	18.5
M18×2.5	15.5	M10×1.0	9.0	M20×1.0	19.0
M20×2.5	17.5	M10×0.75	9.25	M22×2.0	20.0
M24×3.0	21.0	M11×1.0	10.0	M22×1.5	20.5
M27×3.0	24.0	M11×0.75	10.25	M22×1.0	21.0
M30×3.5	26.5	M12×1.5	10.5	M24×2.0	22.0
		M12×1.25	10.75	M24×1.5	22.5
		M12×1.0	11.0	M24×1.0	23.0

Surface roughness · Oberflächenrauigkeit

D

Technical Info
Technische Info

Type Typ	Code	Calculation method · Berechnungsmethode	Calculation example (figure) · Meßaufnahme (Abb.)
Arithmetic average deviation of profile Mittlere Rauhtiefe	Ra	<p>Within sampling length l, the arithmetic average absolute value of profile deviation is</p> $R_a = \frac{1}{l} \int_0^l y(x) dx$ <p>In the formula, the profile deviation y is the distance between profile points and reference line in the measuring direction. Reference line is the profile least-square average line O. This line divide the profile and make the sum of squares of profile deviation to be the minimum within the sampling length.</p> <p>Der Mittelrauhwert R_a ist der arithmetische Mittelwert der absoluten Beträge der Abstände y des Rauheitsprofils von der Mittellinie innerhalb der Messstrecke. Dies ist gleichbedeutend mit der Höhe des Rechtecks, dessen Länge gleich der Gesamtstrecke l ist und das flächengleich mit der Summe der zwischen dem Rauheitsprofil und der Mittellinie eingeschlossenen Fläche ist $y=f$</p>	
Irregularity ten-point high Gemittelte Rauhtiefe	Rz	<p>Within sampling length l, the sum of the average value of heights of five highest profile peak and the depths of five deepest profile valleys</p> $R_z = \frac{\sum_{i=1}^5 y_{pi} + \sum_{i=1}^5 y_{vi}}{5}$ <p>In the formula, y_{pi} means the height of 'i'th highest profile peak. In the formula, y_{vi} means the depth of 'i'th deepest profile valley. Maximum height of profile R_y: the distance between the top profile peak line and the bottom profile valley line in the longitudinal direction within the sampling length l.</p> <p>Die gemittelte Rauhtiefe R_z ist das arithmetische Mittel aus den Einzelrauhtiefen fünf aufeinander grenzender Einzelmessstrecken gleicher Länge. R_z wird ebenfalls in (μm) angegeben.</p>	
Maximum height of profile Maximale Rauhtiefe	Ry	<p>The distance between the inner profile peak line and the bottom profile valley line in the longitudinal direction within the sampling length l. Top profile peak line is the line that parallels to the reference line and passes through the highest point of profile peak. Bottom profile line is the line that parallels to the reference line and passes through the lowest point of profile valley.</p> <p>Die maximale Rauhtiefe R_y ist die größte der auf der Gesamtmeßstrecke l vorkommenden Einzelrauhtiefen, R_y wird auch in (μm) Mikrometer angegeben. (Bemerkung) Um R_z herausfinden, wird ein Anteil ohne außergewöhnliche Höhen und Tiefen als Stichprobenlänge ausgewählt und als Schwachstelle betrachtet.</p>	

General Technical Inform · Allgemeine Technische Info

Material comparison table · Werkstoffe Vergleichstabelle

ISO	Country and Standard · Standardbezeichnung nach Länder										
	China	USA	Germany		Great Britain		Sweden	France	Italy	Spain	Japan
	GB	AISI/SAE	W.-nr	DIN	BS	EN	SS	AFNOR	UNI	UNE	JIS
P	Alloy steel · Legierter Stahl										
	15	1015	1.0401	C15	080M15	-	1350	CC12	C15C16	F.111	-
	20	1020	1.0402	C22	050A20	2C	1450	CC20	C20C21	F.112	-
	35	1035	1.0501	C35	060A35	-	1550	CC35	C35	F.113	-
	45	1045	1.0503	C45	080M40	-	1650	CC45	C45	F.114	-
	55	1055	1.0535	C55	070M55	-	1655	-	C55	-	-
	60	1060	1.0601	C60	080A62	43D	-	CC55	C60	-	-
	Y15	1213	1.7015	9SMn28	230M07	-	1912	S250	CF9SMn28	11SMn28	SUM22
	-	12L13	1.0718	9SMnPb28	-	-	1914	S250Pb	CF9MnPb28	11SMnPb28	SUM22L
	-	-	1.0722	10SPb20	-	-	-	10PbF2	CF10Pb20	10SPb20	-
	-	1140	1.0726	35S20	212M36	8M	1957	35MF4	-	F210G	-
	Y13	1215	1.0736	9SMn36	240M07	1B	-	S300	CF9SMn36	12SMn35	-
	-	12L14	1.0737	9SMnPb36	-	-	1926	S300Pb	CF9SMnPb36	12SMnP35	-
	55Si2Mn	9255	1.0904	55Si9	250A53	45	2085	55S7	55Si8	56Si7	-
	-	9262	1.0961	60SiCr7	-	-	-	60SC7	60SiCr8	60SiCr8	-
	15	1015	1.1141	Ck15	080M15	32C	1370	XC12	C16	C15K	S15C
	40Mn	1039	1.1157	40Mn4	150M36	15	-	35M5	-	-	-
	25	1025	1.1158	Ck25	-	-	-	-	-	-	S25C
	35Mn2	1335	1.1167	36Mn5	-	-	2120	40Mn5	-	36Mn5	SMn438(H)
	30Mn	1330	1.1170	28Mn6	150M28	14A	-	20M5	C28Mn	-	SCMn1
	35Mn	1035	1.1183	Cf35	060A35	-	1572	XS38TS	C36	-	S35C
	Ck45	1045	1.1191	45	080M46	-	1672	XC42	C45	C45K	S45C
	55	1055	1.1203	Ck55	070M55	-	-	XC45	C50	C55K	S55C
	50	1050	1.1213	Cf53	060A52	-	1674	XC48TS	C53	-	S50C
	60Mn	1060	1.1221	Ck60	080A62	43D	1678	XC60	C60	-	S58C
	-	1095	1.1274	Ck101	060A96	-	1870	-	-	-	SUP4
	-	-	1.3401	X120Mn12	Z120M12	-	-	X120M12	XG120Mn12	X120Mn12	SCMnH/1
	Gr15;45Gr	52100	1.3505	100Cr6	534A99	31	2258	100C6	100Cr6	F.131	SUJ2
	-	ASTM A204Gr.A	1.5415	15Mo3	1501-240	-	2912	15D3	16Mo3KW	16Mo3	-
	-	4520	1.5426	16Mo5	1503-245-420	-	-	-	16Mo5	16Mo5	-
-	ASTM A350LF5	1.5622	14Ni6	-	-	-	16N6	14Ni6	15Ni6	-	
-	ASTM A353	1.5662	X8Ni9	1501-509;510	-	-	-	X10Ni9	XBNI09	-	

D

Technical Info
Technische Info

General Technical Inform · Allgemeine Technische Info

Material comparison table · Werkstoffe Vergleichstabelle

ISO	Country and Standard · Standardbezeichnung nach Länder										
	China	USA	Germany		Great Britain		Sweden	France	Italy	Spain	Japan
	GB	AISI/SAE	W.-nr	DIN	BS	EN	SS	AFNOR	UNI	UNE	JIS
P	Alloy steel · Legierter Stahl										
	-	2515	1.5680	12Ni19	-	-	-	Z18N5	-	-	-
	-	3135	1.5710	36NiCr6	640A35	111A	-	35NC6	-	-	SNC236
	-	3415	1.5732	14NiCr10	-	-	-	14NC11	16NiCr11	15NiCr11	SNC415(H)
	-	3415 3310	1.5752	14NiCr14	655M13 655A12	36A	-	12NC15	-	-	SNC815(H)
	-	9840	1.6511	36CrNiMo4	816M40	110	-	40NCD3	38CrNiMo4(KB)	35CrNiMo4	-
	-	8620	1.6523	21NiCrMo2	850M20	362	2503	20NCD2	20NiCrMo2	20NiCrMo2	SNCCM220(H)
	-	8740	1.6546	40NiCrMo2	311-Type7	-	-	-	40NiCrMo2(KB)	40NiCrMo2	SNC240
	40CrNiMoA	4340	1.6582	34CrNiMo6	817M40	24	2541	35NCD6	35CrNiMo6(KB)	-	-
	-	-	1.6587	17CrNiMo6	820A16	-	-	18NCD6	-	14CrNiMo13	-
	15Cr	5015	1.7015	15Cr3	523M15	-	-	12C3	-	-	SCr415(H)
	35Cr	5132	1.7033	34Cr4	530A32	18B	-	32C4	34Cr4(KB)	35Cr4	SCr430(H)
	40Cr	5140	1.7035	41Cr4	530M40	18	-	42C4	41Cr4	42Cr4	SCr440(H)
	40Cr	5140	1.7045	42Cr4	-	-	2245	-	-	42Cr4	SCr440
	18CrMn	5115	1.7131	16MnCr15	(527M20)	-	2511	16MC5	16MnCr15	16MnCr15	-
	20CrMn	5155	1.7176	55Cr3	527A60	48	-	55C3	-	-	SUP9(A)
	30CrMn	4130	1.7218	25CrMo4	1717CDS110	-	2225	25CD4	25CrMo4(KB)	55Cr3	SCM420; SCM430
	35CrMo	4137;4135	1.7220	34CrMo4	708A37	19B	2234	35CD4	35CrMo4	34CrMo4	SCM432; SCRRM3
	40CrMoA	4140;4142	1.7223	41CrMo4	708M40	19A	2244	42CD4TS	41CrMo4	41CrMo4	SCM440
	42CrMo 42CrMnMo	4140	1.7225	42CrMo4	708M40	19A	2244	42CD4	42CrMo4	42CrMo4	SCM440(H)
	-	-	1.7262	15CrMo5	-	-	2216	12CD4	-	12CrMo4	SCM415(H)
	-	ASTM A182 F11;F12	1.7335	13CrMo44	1501- 620Gr.27	-	-	15CD3.5; 15CD4.5	14CrMo44	14CrMo45	-
	-	-	1.7361	32CrMo12	722M24	40B	2240	30CD12	32CrMo12	F.124.A	-
	-	ASTM A182 F.22	1.7380	10CrMo910	1501- 622Gr.31;45	-	2218	12CD9;10	12CrMo9,10	TU.H	-
	-	-	1.7715	14MoV63	1503-660-440	-	-	-	-	13MoCrV6	-
	50CrVA	6150	1.8159	50CrV4	735A50	47	2230	50CV4	50CrV4	51CrV4	SUP10
	-	-	1.8509	41CrAlMo7	905M39	41B	2940	40CAD6,12	41CrAlMo7	41CrAlMo7	-
	-	-	1.8523	39CrMoV139	897M39	40C	-	-	36CrMoV12	-	-

D

Technical Info
Technische Info

Material comparison table · Werkstoffe Vergleichstabelle

ISO	Country and Standard · Standardbezeichnung nach Länder										
	China	USA	Germany		Great Britain		Sweden	France	Italy	Spain	Japan
	GB	AISI/SAE	W.-nr	DIN	BS	EN	SS	AFNOR	UNI	UNE	JIS
P	Tool steel · Werkzeugstahl										
	T10	W.110	1.1545	C105W1	-	-	1880	Y1105	C98KU C100KU	F.515 F.516	-
	T12A	W.112	1.1663	C125W	-	-	-	Y2120	C120KU	(C120)	SK2
	CrV;9SiCr	L3	1.2067	100Cr6	BL3	-	-	Y100C6	-	100Cr6	-
	Cr12	D3	1.2080	X210Cr12	BD3	-	-	Z200Cr12	X210Cr13KU X250Cr12KU	X210Cr12	SKD1
	4Cr5MoVSi	H13	1.2344	X40CrMoV5 1	BH13	-	2242	Z40CDV5	X35CrMoV05KU X40CrMoV51KU	X40CrMoV5	SKD61
	Cr6WV	A2	1.2363	X100CrMoV5 1	BA2	-	2260	Z100CDV5	X100CrMoV51KU	X100CrMoV5	SKD12
	CrWMo	-	1.2419	105WCr6	-	-	2140	105WC13	10WCr6 107WCr5KU	105WCr5	SKS31 SKS2 SKS3
	Cr12W	-	1.2436	X210CrW12	-	-	2312	-	X215CrW12 1KU	X210CrW12	SKD2
	5CrNiMo	S1	1.2542	45WCrV7	BS1	-	2710	-	45WCrV8KU	45WCrSi8	-
	3Cr2W8V	H21	1.2581	X30WCrV9 3 X30WCrV93KU	BH21	-	-	Z30WCV9	X28W09KU X30WCrV9 3KU	X30WCrV9	SKD5
	Cr12MoV	-	1.2601	X165CrMoV 12	-	-	2310	-	X165CrMoW12KU	X160CrMoV12	SKD11
	5CrNiMo	L6	1.2713	55NiCrMoV6	-	-	-	55NCDV7	-	F.250.S	SKT4
	V	W210	1.2833	100V1	BW2	-	-	Y1105V	-	-	SKS43
	W6Mo5Cr4V2Co5	-	1.3243	S6-5-2-5	-	-	2723	Z85WDCV	HS6-5-2-5	HS6-5-2-5	SKH55
	W18Cr4VCo5	T4	1.3255	S18-1-2-5	BT4	-	-	Z80WKCV 10-05-04-01	X78WCo1805KU	HS18-1-1-5	SKH3
	W6Mo5Cr4V2	M2	1.3343	S6-5-2	BM2	-	2722	Z85WDCV 06-05-04-02	X82WMo0605KU	HS6-5-2	SKH9
	-	M7	1.3348	S2-9-2	-	-Z-	2782	Z100WCWV 09-02-04-02	HS2-9-2	HS2-9-2	-
	W18Cr4V	T1	1.3355	S18-0-1	BT1	-	-	Z80WCV 18-04-01	X75W18KU	HS18-0-1	SKH2
	W6Mo5Cr4V3	M3	-	S6-5-3	-	-	-	-	-	-	SKH52
-	M42	-	-	BM42	-	-	-	-	-	SKH59	

General Technical Inform - Allgemeine Technische Info

D

Technical Info
Technische Info

ISO	Country and Standard · Standardbezeichnung nach Länder					Main application Hauptanwendung
	China	USA	Germany	Japan	Daido Steel Co., Ltd (Japan)	
	GB	AISI/SAE	DIN	JIS	DAIDO	
P	Plastic die steel · Gesenkstahl					
	-	P20 mod.		-	PX5N	For mass production of large mirror dies. Automobile tail light, front fender of car, video camera, household electrical appliances etc Große hochglänzende Präzisionsgesenke für die Serienproduktion. Automobilteile, Videokameras, elektr. Haushaltsgeräte ect.
	-	-		-	NAK55	High precision mirror die. Video camera, music disc, Cosmetic Containers, transparent covers, transparent films etc Hochglänzende Präzisionsgesenke für Videokameras, Musik CDs, Kosmetik Behälter, Transparente Abdeckungen.
	-	-		-	NAK80	High precision mirror die. Video camera, music disc, Cosmetic Containers, transparent covers, transparent films etc Hochglänzende Präzisionsgesenke für Videokameras, Musik CDs, Kosmetik Behälter, Transparente Abdeckungen und Beläge.
	3Cr13	420 mod.		SUS420J2 mod.	S-STAR	For ultra-mirror corrosion resistant precise dies. Accessories of camera, CD, lens, watch case. Für ultra-fein spiegelnde korrosionsbeständige Gesenke für Zubehör von Kameras. CD, Linsen, Armbanduhren.
	Cold-working die steel · Kaltarbeitsstahl					
	-	02	-	SKS93	YK30	Stamping die, gauge calipers, paper cutter, auxiliary tools Für Gesenkstempel, Meßkaliber, Papierschnidmesser, Werkzeuge
	9CrWMn	01 mod.	-	SKS3 mod.	GOA	Blanking die, gauge calipers, drawing die, taps, Perforated punch. Für Schnittmatrizen, Meßkaliber, Gewindebohrer, Perforationswerkzeuge, Kaltziehsteine
	Cr12MoV	D2	X165CrMoV12	SKD11	DC11	Blanking die, cold forming die, cold drawing die, forming roller, punch Für Schnittmatrizen, Kaltformpressgesenke, Kaltziehsteine, Formwalzen.
	-	D2 mod.	-	SKD11 mod.	DC53	Blanking die, cold forming die, cold drawing die, forming roll, punch Für Schnittmatrizen, Kaltformpressgesenke, Kaltziehsteine, Formwalzen.
Hot-working die steel · Warmarbeitsstahl						
4Cr5MoSiV1	H13	X40CrMoV51	SKD61	DHA1	Aluminum-compression die, connecting parts of compression die, hot stamping die, hot extrusion die, thermal shear cutting blade Aluminium Druckgesenke, Verbindungsstücke für Druckgesenke, Heißpressgesenke, Heiß-Extruder-Gesenke, warmfeste Schnittmesser ect.	
-	-	-	-	DH21	Long life Aluminum compression die Alu-Druckgesenke für lange Lebensdauer	
-	-	-	-	DH31-S	Compression die, Druckgesenke	
-	-	-	-	DH2F	Compression die, plastic die Druckgesenke, Plastik-Gesenke	

General Technical Inform - Allgemeine Technische Info

D

Technical Info
Technische Info

ISO	Country and Standard · Standardbezeichnung nach Länder										
	China	USA	Germany		Great Britain		Sweden	France	Italy	Spain	Japan
	GB	AISI/ SAE	W.-nr	DIN	BS	EN	SS	AFNOR	UNI	UNE	JIS
M	Stainless steel · Rostfreier Stahl										
	0Cr13; 1Cr12	403	1.4000	X6Cr13	403S17	-	2301	Z6C13	X6Cr13	F.3110	SUS403
	-	-	1.4001	X7Cr14	-	-	-	-	-	F.8401	-
	1Cr13	410	1.4006	X10Cr13	410S21	56A	2302	Z10C14	X12Cr13	F.3401	SUS410
	1Cr17	430	1.4016	X6Cr17	430S15	60	220	Z8C17	X8Cr17	F.3113	SUS430
	2Cr13	410	1.4021	X20Cr13	S62	56B; 56C	-	Z20C13	X20C13	F.3401	SUS410
	-	-	1.4027	G-X20Cr14	420C29	56B	-	Z20C13M	-	-	SCS2
	4Cr13	-	1.4034	X46Cr13	420S45	56D	2304	Z40CM Z38C13M	X40Cr14	F.3405	SUS420J2
	1Cr17Ni2	431	1.4057	X20CrNi172	431S29	57	2321	Z15CNi6.02	X16CNi16	F.3427	SUS431
	Y1Cr17	430F	1.4104	X12CrMoS17	-	-	2383	Z10CF17	X10CrS17	F.3117	SUS430F
	1Cr17Mo	434	1.4113	X6CrMo171	434S17	-	2325	Z8CD17.01	X8CrMo17	-	SUS434
	-	-	1.4313	X5CrNi134	425C11	-	-	Z4CND13.4M	-	-	SCS5
	-	-	1.4408	G-X6CrNiMo1810	316C16	-	-	-	-	F.8414	SCS14
	4Cr9Si2	HW3	1.4718	X45CrSi93	401S45	52	-	Z45CS9	X45CrSi8	F.322	SUH1
	0Cr13Al	405	1.4724	X10CrAl13	403S17	-	-	Z10C13	X10CrAl12	F.311	SUS405
	Cr17	430	1.4742	X10CrAl18	430S15	60	-	Z10CAS18	X8Cr17	F.3113	SUS430
	8Cr20Si2Ni	HNV6	1.4757	X80CrNiSi20	443S65	59	-	Z80CSN20.02	X80CrSiNi20	F.320V	SUH4
	2Cr25N	446	1.4762	X10CrAl24	-	-	2322	Z10CAS24	X16Cr26	-	SUH446
	Austenitic stainless steel · Austenitischer Rostfreier Stahl										
	0Cr18Ni9	304	1.4301	X5CrNi1810	304S15	58E	2332	Z6CN18.09	X5CrNi1810	F.3551; F.3541; F.3504	SUS304
	1Cr18Ni9MoZr	303	1.4305	X10CrNiS189	303S21	58M	2346	Z10CNF18.09	X10CrNiS18.09	F.3508	SUS303
	0Cr19Ni10	304L	1.4306	X2CrNi1911	304S12	-	2352	Z2CN18.10	X2CrNi18.11	F.3503	SCS19
	-	-	1.4308	G-X6CrNi189	304C15	-	-	Z6CN18.10M	-	-	SCS13
	Cr17Ni7	301	1.4310	X12CrNi177	-	-	2331	Z12CN17.07	X12CrNi1707	F.3517	SUS301
	-	304LN	1.4311	X2CrNiN1810	304S62	-	2371	Z2CN18.10	-	-	SUS304LN
	0Cr19Ni9	304	1.4350	X5CrNi189	304S31	58E	-	Z6CN18.09	X5CrNi1810	-	SUS304
	0Cr17Ni11Mo2	316	1.4401	X5CrNiMo1712	316S16	Z6CND17.11	2347	1.4401	X5CrNiMo1712	F.3543	SUS316
	00Cr17Ni13Mo2	316LN	1.4429	X2CrNiMoN17133	-	-	2375	Z2CND17.13	-	-	SUS316LN
	0Cr27Ni12Mo3	316L	1.4435	X2CrNiMo18143	316S12	-	2353	Z2CDN17.13	X2CrNiMo1713	-	SCS16,
	00Cr19Ni13Mo3	317L	1.4438	X2CrNiMo17133	317S12	-	2367	Z2CND19.15	X2CrNiMo18.16	-	SUS317L
	-	329L	1.4460	X8CrNiMo275	-	-	2324	-	-	-	SUS329L; SCH11; SCS11
	1Cr18Ni9Ti	321	1.4541	X6CrNiTi1810	2337	321S12	58B	Z6CNT18.10	X6CrNiTi1811	F.3553	SUS321
	1Cr18Ni11Nb	347	1.4550	X6CrNiNb1810	347S17	58F	2338	Z6CNNb18.1	X6CrNiTi1811	F.3552	SUS347
	Cr18Ni12Mo2Ti	316Ti	1.4571	X6CrNiMoTi17122	320S17	58J	2350	Z6NDT17.12	X6CrNiMoTi17	F.3535	-

General Technical Inform - Allgemeine Technische Info

D

Technical Info
Technische Info

ISO	Country and Standard · Standardbezeichnung nach Länder											
	China	USA	Germany		Great Britain		Sweden	France	Italy	Spain	Japan	
	GB	AISI/ SAE	W.-nr	DIN	BS	EN	SS	AFNOR	UNI	UNE	JIS	
	Austenitic stainless steel · Austenitischer Rostfreier Stahl											
	-	-	1.4581	G-X5CrNiMoNb1810	318C7	-	-	Z4CNDNb1812M	XG8CrNiMo18	-	SCS22	
	Cr17Ni12Mo3Nb	318	1.4583	X10CrNiMoNb1812	-	-	-	Z6CNDNb1713B	X6CrNiMoTiNb17	-	-	
	1Cr23Ni13	309	1.4828	X15CrNiSi2012	309S24	-	-	Z15CNS20.1	-	-	SUH309	
	0Cr25Ni20	310S	1.4845	X12CrNi2521	310S24	-	2361	Z12CN2520	X6CrNi2520	F.331	SUH310	
	Cr15Ni36W3Ti	330	1.4864	X12NiCrSi3616	-	-	-	Z12CNS35.1	-	-	SUH330	
	-	-	1.4865	G-X40NiCrSi3818	330C11	-	-	-	XG50NiCr3919	-	SCH15	
	5Cr2Mn9Ni4N	EV8	1.4871	X53CrMnNiN219	349S54; 321S12	-	58B	-	Z52CMN21.0	X53CrMnNiN219	-	SUH35
	1Cr18Ni9Ti	321	1.4878	X12CrNiTi189	321S320	58C	-	Z6CNT18.12	X6CrNiTi1811	F.3523	SU321	

ISO	Country and Standard · Standardbezeichnung nach Länder								
	China	USA	Germany	Great Britain	Sweden	France	Italy	Spain	Japan
	Nodular cast iron · GGG								
	QT400-18	60-40-18	GGG40	400/17	0717-02	FGS370-17	GS370-17	FGE38-17	FCD400
	QT450-10	65-45-12	--	420/12	--	FGS400-12	GS400-12	FGE42-12	FCD450
	QT500-7	70-50-05	GGG50	500/7	0727-02	FGS500-7	GS500-7	FGE50-7	FCD500
	QT600-3	80-60-03	GGG60	600/7	0732-03	FGS600-2	GS600-2	FGE60-2	FCD600
	QT700-2	100-70-03	GGG70	700/2	0737-01	FGS700-2	GS700-2	FGE70-2	FCD700
	QT800-2	120-90-02	GGG80	800/2	0864-03	FGS800-2	GS800-2	FGE80-2	FCD800
	QT900-2	--	--	900/2	--	--	--	--	--
	Grey cast iron · Grauguss								
	--	NO.60	GG40	--	0140	FGL400	--	--	
	HT350	NO.50	GG35	350	0135	FGL350	G35	FG35	FC350
	HT300	NO.45	GG30	300	0130	FGL300	G30	FG30	FC300
	HT250	NO.35	GG25	250	0125	FGL250	G25	FG25	FC250
	HT200	NO.30	GG20	200	0120	FGL200	G20	FG20	FC200
	HT150	NO.20	GG15	150	0115	FGL150	G15	FG15	FC150
	HT100	--	--	100	0110	--	G10	--	FC100

Fitting dimension tolerance · Passtoleranzen

Basic dimensions (mm)		Standard tolerance class of holes · Standard-Toleranzklassen																	
		IT1	IT2	IT3	IT4	IT5	IT6	IT7	IT8	IT9	IT10	IT11	IT12	IT13	IT14	IT15	IT16	IT17	IT18
>	≤	µm											mm						
---	3	0.8	1.2	2	3	4	6	10	14	25	40	60	0.1	0.14	0.25	0.4	0.6	1	1.4
3	6	1	1.5	2.5	4	5	8	12	18	30	48	75	0.12	0.18	0.3	0.48	0.75	1.2	1.8
6	10	1	1.5	2.5	4	6	9	15	22	36	58	90	0.15	0.22	0.36	0.58	0.9	1.5	2.2
10	18	1.2	2	3	5	8	11	18	27	43	70	110	0.18	0.27	0.43	0.7	1.1	1.8	2.7
18	30	1.5	2.5	4	6	9	13	21	33	52	84	130	0.21	0.33	0.52	0.84	1.3	2.1	3.3
30	50	1.5	2.5	4	7	11	16	25	39	62	100	160	0.25	0.39	0.62	1	1.6	2.5	3.9
50	80	2	3	5	8	13	19	30	46	74	120	190	0.3	0.46	0.74	1.2	1.9	3	4.6
80	120	2.5	4	6	10	15	22	35	54	87	140	220	0.35	0.54	0.87	1.4	2.2	3.5	5.4
120	180	3.5	5	8	12	18	25	40	63	100	160	250	0.4	0.63	1	1.6	2.5	4	6.3
180	250	4.5	7	10	14	20	29	46	72	115	185	290	0.46	0.72	1.15	1.85	2.9	4.6	7.2
250	315	6	8	12	16	23	32	52	81	130	210	320	0.52	0.81	1.3	2.1	3.2	5.2	8.1
315	400	7	9	13	18	25	36	57	89	140	230	360	0.57	0.89	1.4	2.3	3.6	5.7	8.9
400	500	8	10	15	20	27	40	63	97	155	250	400	0.63	0.97	1.55	2.5	4	6.3	9.7
500	630	9	11	16	22	32	44	70	110	175	280	440	0.7	1.1	1.75	2.8	4.4	7	11
630	800	10	13	18	25	36	50	80	125	200	320	500	0.8	1.25	2	3.2	5	8	12.5
800	1000	11	15	21	28	40	56	90	140	230	360	560	0.9	1.4	2.3	3.6	5.6	9	14
1000	1250	13	18	24	33	47	66	105	165	260	420	660	1.05	1.65	2.6	4.2	6.6	10.5	16.5
1250	1600	15	21	29	39	55	78	125	195	310	500	780	1.25	1.95	3.1	5	7.8	12.5	19.5
1600	2000	18	25	35	46	65	92	150	230	370	600	920	1.5	2.3	3.7	6	9.2	15	23
2000	2500	22	30	41	55	78	110	175	280	440	700	1100	1.75	2.8	4.4	7	11	17.5	28
2500	3150	26	36	50	68	96	135	210	330	540	860	1350	2.1	3.3	5.4	8.6	13.5	21	33

Note:
From IT1 to IT5, the standard tolerance with basic dimension more than 500 mm is as trial.
When the basic dimension 1 mm, the tolerances from IT4 to IT8 are invalid.

Bemerkung:
Für die Standard Toleranzen IT1 bis IT5 bei Durchmesser über 500 mm ist eine Anpassung notwendig. Bei Basis abmessungen unter 1 mm ist das Toleranzfeld IT4 bis IT8 ungültig.

The shaft lower deviation (ei) and upper deviation (es) can be obtained by basic tolerance and standard tolerance (IT) of shaft.

Toleranz Einheitswelle: Die geringste Abweichung (ei) und die größte Abweichung (es) sind als Basis bzw. Standard-Toleranzen (IT) in der Tabelle angegeben.

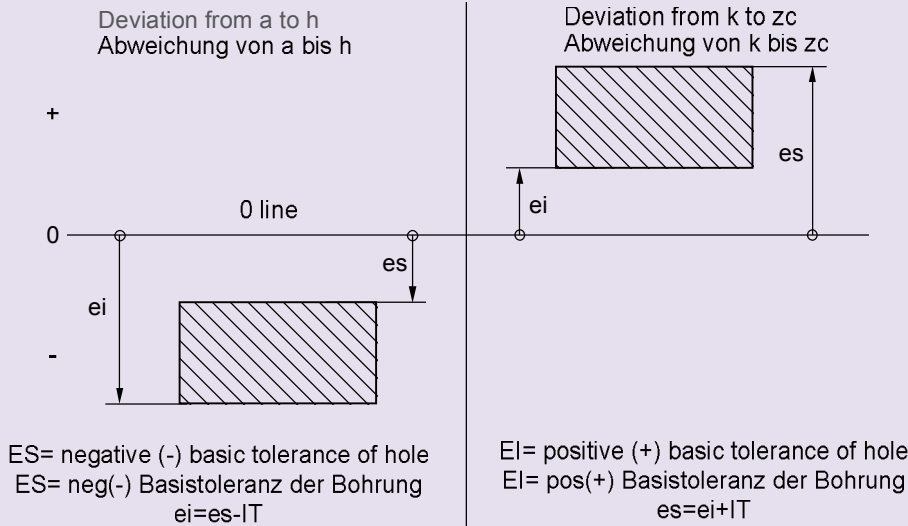

The hole lower deviation (EI) and upper deviation (ES) can be obtained by basic tolerance and standard tolerance (IT) of hole.

Toleranz Einheitsbohrung: Die geringste Abweichung (EI) und die größte Abweichung (ES) sind als Basis bzw. Standard-Toleranzen (IT)- Bohrung in der Tabelle angegeben.

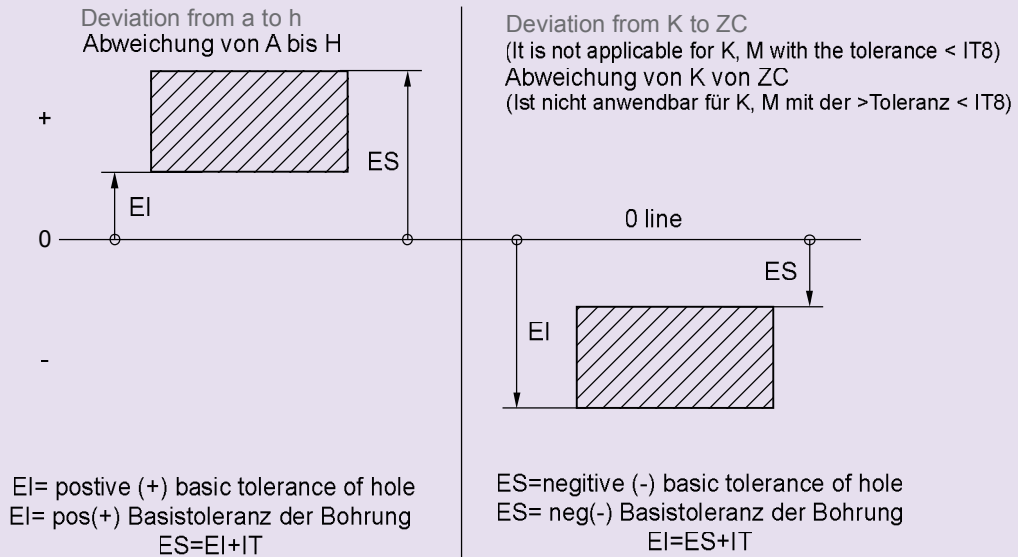

For example: for a hole with diameter 3 mm and tolerance H7, we can find that the lower deviation EI=0 in relation to H7 from the basic tolerance table, and the standard tolerance IT=10µm corresponding to H7, thus the upper deviation ES=EI+IT=10µm. Therefore the hole fitting

dimension is $\varnothing 3_0^{+0.01}$ mm.

Beispiel: Bei einem Durchmesser von 3mm und einer Toleranz H7 ist bei der Basis Toleranz H7 EI=0 bei der Standard-Toleranz H7 ist es IT=10µm. Die größte Abweichung ist demzufolge: ES=EI+IT=10µm.

Die Bohrungstoleranz ist bei einem $\varnothing 3_0^{+0.01}$ mm.

General Technical Inform ▪ Allgemeine Technische Info

- Basic deviations value of shaft
- Basistoleranzwerte Einheitswelle

Diameter Durchmesser Ø (mm)		Basic deviation value · Basistoleranzwerte											
		Upper deviation es · Höchstabweichung											
		Standard tolerance class · Standard-Toleranzklasse											
>	≤	a	b	c	cd	d	e	ef	f	fg	g	h	js
---	3	-270	-140	-60	-34	-20	-14	-10	-6	-4	-2	0	In the formula Deviation = ± $\frac{IT_n}{2}$, ITn is the IT value corresponding to 'n'. Die Formel für die Abweichung = ± $\frac{IT_n}{2}$, ITn ist der IT Wert entsprechend zu "n" zugeordnet.
3	6	-270	-140	-70	-46	-30	-20	-14	-10	-6	-4	0	
6	10	-280	-150	-80	-56	-40	-25	-18	-13	-8	-5	0	
10	14	-290	-150	-95		-50	-32		-16		-6	0	
14	18												
18	24	-300	-160	-110		-65	-40		-20		-7	0	
24	30												
30	40	-310	-170	-120		-80	-50		-25		-9	0	
40	50	-320	-180	-130									
50	65	-340	-190	-140		-100	-60		-30		-10	0	
65	80	-360	-200	-150									
80	100	-380	-220	-170		-120	-72		-36		-12	0	
100	120	-410	-240	-180									
120	140	-460	-260	-200		-145	-85		-43		-14	0	
140	160	-520	-280	-210									
160	180	-580	-310	-230									
180	200	-660	-340	-240									
200	225	-740	-380	-260		-170	-100		-50		-15	0	
225	250	-820	-420	-280									
250	280	-920	-480	-300		-190	-110		-56		-17	0	
280	315	-1050	-540	-330									
315	355	-1200	-600	-360		-210	-125		-62		-18	0	
355	400	-1350	-680	-400									
400	450	-1500	-760	-440		-230	-135		-68		-20	0	
450	500	-1650	-840	-480									
500	560					-260	-145		-76		-22	0	
560	630												
630	710					-290	-160		-80		-24	0	
710	800												
800	900					-320	-170		-86		-26	0	
900	1000												
1000	1120					-350	-195		-98		-28	0	
1120	1250												
1250	1400					-390	-220		-110		-30	0	
1400	1600												
1600	1800					-430	-240		-120		-32	0	
1800	2000												
2000	2240					-480	-260		-130		-34	0	
2240	2500												
2500	2800					-520	-290		-145		-38	0	
2800	3150												

Note: 1. If basic dimension ≤ 1mm, the basic deviation a and b are not adopted.

Bemerkungen: 1. Bei Abmessungen ≤ 1mm, sind die Basisabweichungen a und b nicht berücksichtigt.

General Technical Inform - Allgemeine Technische Info

µm

Basic deviation value · Basistoleranzwerte Einheitswelle																			
Lower deviation ei · geringste Abweichung																			
IT5 IT6	IT7	IT8	IT4 IT7	≤IT3 >IT7	Standard tolerance class · Standard-Toleranzklasse														
j			k		m	n	p	r	s	t	u	v	x	y	z	zn	zb	zc	
-2	-4	-6	0	0	+2	+4	+6	+10	+14		+18		+20		+26	+32	+40	+60	
-2	-4		+1	0	+4	+8	+12	+15	+19		+23		+28		+35	+42	+50	+80	
-2	-5		+1	0	+6	+10	+15	+19	+23		+28		+34		+42	+52	+67	+97	
-3	-6		+1	0	+7	+12	+18	+23	+28		+33		+40		+50	+64	+90	+130	
												+39	+45		+60	+77	+108	+150	
-4	-8		+2	0	+8	+15	+22	+28	+35		+41	+47	+54	+63	+73	+98	+136	+188	
											+41	+48	+55	+64	+75	+88	+118	+160	+218
-5	-10		+2	0	+9	+17	+26	+34	+43		+48	+60	+68	+80	+94	+112	+148	+200	+274
											+54	+70	+81	+97	+114	+136	+180	+242	+325
-7	-12		+2	0	+11	+20	+32	+41	+53	+66	+87	+102	+122	+144	+172	+226	+300	+405	
								+43	+59	+75	+102	+120	+146	+174	+210	+274	+360	+480	
-9	-15		+3	0	+13	+23	+37	+51	+71	+91	+124	+146	+178	+214	+258	+335	+445	+585	
								+54	+79	+104	+144	+172	+210	+254	+310	+400	+525	+690	
-11	-18		+3	0	+15	+27	+43	+63	+92	+122	+170	+202	+248	+300	+365	+470	+620	+800	
								+65	+100	+134	+190	+228	+280	+340	+415	+535	+700	+900	
								+68	+108	+146	+210	+252	+310	+380	+465	+600	+780	+1000	
-13	-21		+4	0	+17	+31	+50	+77	+122	+166	+236	+284	+350	+425	+520	+670	+880	+1150	
								+80	+130	+180	+258	+310	+385	+470	+575	+740	+960	+1250	
								+84	+140	+196	+284	+340	+425	+520	+640	+820	+1050	+1350	
-16	-26		+4	0	+20	+34	+56	+94	+158	+218	+315	+385	+475	+580	+710	+920	+1200	+1550	
								+98	+170	+240	+350	+425	+525	+650	+790	+1000	+1300	+1700	
-18	-28		+4	0	+21	+37	+62	+108	+190	+268	+390	+475	+590	+730	+900	+1150	+1500	+1900	
								+114	+208	+294	+435	+530	+660	+820	+1000	+1300	+1650	+2100	
-20	-32		+5	0	+23	+40	+68	+126	+232	+330	+490	+595	+740	+920	+1100	+1450	+1850	+2400	
								+132	+252	+360	+540	+660	+820	+1000	+1250	+1600	+2100	+2600	
			0	0	+26	+44	+78	+150	+280	+400	+600								
								+155	+310	+450	+660								
			0	0	+30	+50	+88	+175	+340	+500	+740								
								+185	+380	+560	+840								
			0	0	+34	+56	+100	+210	+430	+620	+940								
								+220	+470	+680	+1050								
			0	0	+40	+66	+120	+250	+520	+780	+1150								
								+260	+580	+840	+1300								
			0	0	+48	+78	+140	+300	+640	+960	+1450								
								+330	+720	+1050	+1600								
			0	0	+58	+92	+170	+370	+820	+1200	+1850								
								+400	+920	+1350	+2000								
			0	0	+68	+110	+195	+440	+1000	+1500	+2300								
								+460	+1100	+1650	+2500								
			0	0	+76	+135	+240	+550	+1250	+1900	+2900								
								+580	+1400	+2100	+3200								



Technical Info
Technische Info

General Technical Inform · Allgemeine Technische Info

- Basic deviations value of hole
- Basistoleranzwerte Einheitsbohrung

Diameter Durchmesser Ø (mm)		Basic deviation value · Basis-Toleranzwerte Einheitswelle																						
		Lower deviation EI · geringste Abweichung EI											Upper deviation ES · Höchstabweichung ES											
		Standard tolerance class · Standard-Toleranzklasse											IT6	IT7	IT8	≤IT8	>IT8	≤IT8	>IT8	≤IT8	>IT8	≤IT7		
>	≤	A	B	C	CD	D	E	EF	F	FG	G	H	JS	J		K		M		N		P to ZC		
---	3	+270	+140	+60	+34	+20	+14	+10	+6	+4	+2	0	in the formula Deviation = ± $\frac{IT_n}{2}$, ITn is the IT value corresponding to 'n'. Die Formel für die Abweichung = ± $\frac{IT_n}{2}$, ITn ist der IT Wert entsprechend zu 'n' zugeordnet.	+2	+4	+6	0	0	-2	-2	-4	-4	Wenn IT ≥ IT7, wird der Δ wert zuaddiert. If IT ≥ IT7, add a Δ value to the relevant value	
3	6	+270	+140	+70	+46	+30	+20	+14	+10	+6	+4	0		+5	+6	+10	-1+Δ		-4+Δ	-4	-8+Δ	0		
6	10	+280	+150	+80	+56	+40	+25	+18	+13	+8	+5	0		+5	+8	+12	-1+Δ		-6+Δ	-6	-10+Δ	0		
10	14	+290	+150	+95		+50	+32		+16		+6	0			+6	+10	+15	-1+Δ		-7+Δ	-7	-12+Δ		0
14	18																							
18	24	+300	+160	+110		+65	+40		+20		+7	0			+8	+12	+20	-2+Δ		-8+Δ	-8	-15+Δ		0
24	30																							
30	40	+310	+170	+120		+80	+50		+25		+9	0			+10	+14	+24	-2+Δ		-9+Δ	-9	-17+Δ		0
40	50	+320	+180	+130																				
50	65	+340	+190	+140		+100	+60		+30		+10	0			+13	+18	+28	-2+Δ		-11+Δ	-11	-20+Δ		0
65	80	+360	+200	+150																				
80	100	+380	+220	+170		+120	+72		+36		+12	0			+16	+22	+34	-3+Δ		-13+Δ	-13	-23+Δ		0
100	120	+410	+240	+180																				
120	140	+460	+260	+200		+145	+85		+43		+14	0			+18	+26	+41	-3+Δ		-15+Δ	-15	-27+Δ		0
140	160	+520	+280	+210																				
160	180	+580	+310	+230		+170	+100		+50		+15	0			+22	+30	+47	-4+Δ		-17+Δ	-17	-31+Δ		0
180	200	+660	+340	+240																				
200	225	+740	+380	+260		+190	+110		+56		+17	0			+25	+36	+55	-4+Δ		-20+Δ	-20	-34+Δ		0
225	260	+820	+420	+280																				
260	280	+920	+480	+300		+210	+125		+62		+18	0			+29	+39	+60	-4+Δ		-21+Δ	-21	-37+Δ		0
280	315	+1050	+540	+330																				
315	355	+1200	+600	+360		+230	+135		+68		+20	0			+33	+43	+66	-5+Δ		-23+Δ	-23	-40+Δ		0
355	400	+1350	+680	+400																				
400	450	+1500	+760	+440		+260	+145		+76		+22	0						0		-26		-44		
450	500	+1650	+840	+480																				
500	560					+290	+160		+80		+24	0						0		-30		-50		
560	630																							
630	710					+320	+170		+86		+26	0						0		-34		-56		
710	800																							
800	900					+350	+195		+98		+28	0						0		-40		-66		
900	1000																							
1000	1120					+390	+220		+110		+30	0						0		-48		-78		
1120	1250																							
1250	1400					+430	+240		+120		+32	0					0		-58		-92			
1400	1600																							
1600	1800					+480	+260		+130		+34	0					0		-68		-110			
1800	2000																							
2000	2240					+520	+290		+145		+38	0					0		-76		-135			
2240	2500																							
2500	2800																							
2800	3150																							



General Technical Inform - Allgemeine Technische Info

µm

Basic deviation value · Basis-Toleranzwerte Einheitswelle												Δ					
Upper deviation ES · Höchstabweichung ES																	
Standard tolerance class >IT7 · Standard-Toleranzklasse > IT7												Standard tolerance class Standard-Toleranzklasse					
P	R	S	T	U	V	X	Y	Z	ZA	ZB	ZC	IT3	IT4	IT5	IT6	IT7	IT8
-6	-10	-14		-18		-20		-26	-32	-40	-60	0	0	0	0	0	0
-12	-15	-19		-23		-28		-35	-42	-50	-80	1	1.5	1	3	4	6
-15	-19	-23		-28		-34		-42	-52	-67	-97	1	1.5	2	3	6	7
-18	-23	-28		-33		-40		-50	-64	-90	-130	1	2	3	3	7	9
					-39	-45		-60	-77	-108	-150						
-22	-28	-35		-41	-47	-54	-63	-73	-98	-136	-188	1.5	2	3	4	8	12
			-41	-48	-55	-64	-75	-88	-118	-160	-218						
-26	-34	-43	-48	-60	-68	-80	-94	-112	-148	-200	-274	1.5	3	4	5	9	14
			-54	-70	-81	-97	-114	-136	-180	-242	-325						
-32	-41	-53	-66	-87	-102	-122	-144	-172	-226	-300	-405	2	3	5	6	11	16
	-43	-59	-75	-102	-120	-146	-174	-210	-274	-360	-480						
-37	-51	-71	-91	-124	-146	-178	-214	-258	-335	-445	-585	2	4	5	7	13	19
	-54	-79	-104	-144	-172	-210	-254	-310	-400	-525	-690						
-43	-63	-92	-122	-170	-202	-248	-300	-365	-470	-620	-800	3	4	6	7	15	23
	-65	-100	-134	-190	-228	-280	-340	-415	-535	-700	-900						
	-68	-108	-146	-210	-252	-310	-380	-465	-600	-780	-1000						
-50	-77	-122	-166	-236	-284	-350	-425	-520	-670	-880	-1150	3	4	6	9	17	26
	-80	-130	-180	-258	-310	-385	-470	-575	-740	-960	-1250						
	-84	-140	-196	-284	-340	-425	-520	-640	-820	-1050	-1350						
-56	-94	-158	-218	-315	-385	-475	-580	-710	-920	-1200	-1550	4	4	7	9	20	29
	-98	-170	-240	-350	-425	-525	-650	-790	-1000	-1300	-1700						
-62	-108	-190	-268	-390	-475	-590	-730	-900	-1150	-1500	-1900	4	5	7	11	21	32
	-114	-208	-294	-435	-530	-660	-820	-1000	-1300	-1650	-2100						
-68	-126	-232	-330	-490	-595	-740	-920	-1100	-1450	-1850	-2400	5	5	7	13	23	34
	-132	-252	-360	-540	-660	-820	-1000	-1250	-1600	-2100	-2600						
-78	-150	-280	-400	-600													
	-155	-310	-450	-660													
-88	-175	-340	-500	-740													
	-185	-380	-560	-840													
100	-210 -220	-430 -470	-620 -680	-940 -1050													
-120	-250 -260	-520 -580	-780 -840	-1150 -1300													
-140	-300 -330	-640 -720	-960 -1050	-1450 -1600													
-170	-370	-820	-1200	-1850													
	-400	-920	-1350	-2000													
-195	-440 -460	-1000 -1100	-1500 -1650	-2300 -2500													
-240	-550 -580	-1250 -1400	-1900 -2100	-2900 -3200													



Technical Info
Technische Info

Hardness reference table (conversion of hardness and strength for ferrous metal) Härte Vergleichstabelle (Konversionstabelle von Härte und Zugfestigkeit für Stahl)

Hardness · Härte				Tensile strength Zugfestigkeit N/mm ²	Hardness · Härte				Tensile strength Zugfestigkeit N/mm ²
Rockwell hardness · Härte		Vickers hardn. · Härte	Brinell hardn. · Härte		Rockwell hardness · Härte		Vickers hardn. · Härte	Brinell hardn. · Härte	
HRC	HRA	HV	HB		HRC	HRA	HV	HB	
32.0	—	304	298	995	24.0	—	249	245	820
31.5	—	300	294	980	23.5	—	246	242	810
31.0	—	296	291	970	23.0	—	243	240	800
30.5	—	292	287	960	22.5	—	240	237	790
30.0	—	289	283	950	22.0	—	237	234	785
29.5	—	285	280	935	21.5	—	234	232	775
29.0	—	281	276	920	21.0	—	231	229	765
28.5	—	278	273	910	20.5	—	229	227	760
28.0	—	274	269	900	20.0	—	226	225	750
27.5	—	271	266	890	19.5	—	223	222	745
27.0	—	268	263	880	19.0	—	221	220	735
26.5	—	264	260	870	18.5	—	218	218	730
26.0	—	261	257	860	18.0	—	216	216	725
25.5	—	258	254	850	17.5	—	214	214	715
25.0	—	255	251	835	17.0	—	211	211	710
24.5	—	252	248	830					

Note: The conversion values for steel in the table are commonly applicable for the steels with carbon from low to high.
Bemerkung: Die in der Tabelle aufgeführten Werte sind für Kohlenstoffstahl anwendbar.

Comparison table for turning inserts chip breaker · Übersichtstabelle der WSP-Spanbrecher

ISO	Application Anwendung	ZCC-CT		Sandvik		Seco		Kennametal		ISCAR		Walter		Mitsubishi		Sumitomo		Tungaloy		Kyocera		Korloy		Ingersoll Tague Tec		
		Neg	Pos	Neg	Pos	Neg	Pos	Neg	Pos	Neg	Pos	Neg	Pos	Neg	Pos	Neg	Pos	Neg	Pos	Neg	Pos	Neg	Pos	Neg	Pos	
		P I hat S	Wiper-finishing Wiper-Schichten	WG		WF WL	WF WK	W-MF2	W-F1	FW MW	FW MW	WF		NF	PF	SW	FW	NLU-W	NLU-W	ASW		WP		VW LW		WS
Finishing Schichten	DF EF		SF HF	PF QF	PF UF 23	FF1 MF1	FF1 F1	FF FN	11 UF LF	SF	PF SM	NF3 NS6	PF4 PF5	FH FS	FJ FV	NSENSU NLU NFA NFL	NLU NFP NFK	TF TS 17	PF 01	DP GP VF	CF	VG VF VL	VF	FG FC VF	FA SA FG	
Semi-finishing Schichten-Mittlere Bearbeitung	DM EM		HM	PM QM	PM UM	MF2	F2	FN	MF	NF TF SM	14 16 17 19	NS6	PS5	SH SA	SW SV MV	NSX	NSC NSK	TS TM AS	PS	HQ CQ CJ	CK DP GP VF XP	VQ VC VB	HMP	WT ML	WT	
Medium machining -light roughing Mittlere Bearb.-leichte Schruppbearbeitung	DM PM		HR	PM QM	PR UR	M3 MF3	F2	MN	MF	GN PP NR	17 19	NM4 NM6	PM5	MV MZ MA	MV MW	NGE NGU NUX	NMU NSF	TM DM	PM	GS CS HS PS	HQ XQ GK G	VM	C25	PC MC MT MG MF	PC MT PMR	
Wiper-medium				WR WM	WM	W-M3 W-R4 W-R7	W-F2	MW RW	MW	WG		NM	PM	MW		NGU-W					WQ					
Roughing Schruppen	DR			PR QR 31		M5 MR5 MR7		RP UN RN		TNM GN	19	NM9		GH MAT MT		NMU NMX	NMU	TH TR TU		PT GT HT	G St-form	HR		RT		
Single Side roughing Einseitige WSP Schruppen	HDR 31HPR DR LR			HR QR		R8 RR9 -56 -57 -UX		RH RM RP		NM		NR6 NR8		HA HZ HH HV HX		NMP NHG NHP NNU NHW				HX		GH VH VT		HT HD HY HZ RX RH	CMX	
M Stainless Steel · Rostfreier Stahl	Wiper-finishing Wiper-Schichten	WG		WF WL WMX	WF WK	W-MF2		FW MW	FW MW	WF			PF	SW	FW	NLU-W	NLU-W									
	Finishing Schichten	EF DF	EF HF	MF	MF UF	FF1 F2 MF1	F1	FF FP	11 UF LF	NF VL	PF SM	NF4	PF4 PF5	FS	FJ FV	NSU NLU	NSU NLU	SS	SS	GU			VF	EA SF	FG	
	Semi-finishing Schichten-Mittlere Bearbeitung	EF EM	EF EM HF HM	MF MM	MF MM UM	MF3	F2	FP	MF	PP TF	14 16 17 19	NM4	PS5	SH MS	SW SV MV	NEX NUP	NSU	SS SM	PS	MS	CK DP GP VF XP	VP2	HMP			
	Medium machining -light roughing Mittlere Bearbeitung -leichte Schruppbearbeitung	EM DM	EM HM	MM	MM UM	R6 56	F2	MP	HP	PP TF	17 19	NM4 NR4	PM5	MS ES MH	MV MW	NGU	NMU	SA S	PM	MS	HQ XQ GK G	HS VP3	C25	EM SU MT	MT PMR WT	
	Wiper medium			WR WM	WM	W-M3		MW RW	MW	WG			PM	MW		NGU -W										
	Roughing Schruppen	ER DR	HR	MR QR PR	MR	R7 R8		MP -P		HTW NR	19	NR4		GH HZ		NMU NMX NHG						VM		ET	CMX	
	Single Side roughing Einseitige WSP Schruppen	ER DR HDR LR		HR QR		-56		RP		NM						NMP NHG NHP NNU NHW	NMP NHG NHP NNU NHW									

General Technical Inform - Allgemeine Technische Info
Comparison table for turning inserts chip breaker · Übersichtstabelle der WSP-Spanbrecher





Comparison table for turning inserts chip breaker · Übersichtstabelle der WSP-Spanbrecher																										
ISO	Application Anwendung	ZCC-CT		Sandvik		Seco		Kennametal		ISCAR		Walter		Mitsubishi		Sumitomo		Tungaloy		Kyocera		Korloy		Ingersoll Tague Tec		
		Neg	Pos	Neg	Pos	Neg	Pos	Neg	Pos	Neg	Pos	Neg	Pos	Neg	Pos	Neg	Pos	Neg	Pos	Neg	Pos	Neg	Pos	Neg	Pos	
Cast iron · Guss	K	Wiper-finishing Wiper-Schlichter	WG		WF WM	WF	W-MF2	W-F1	FW MW	FW MW	WF						NLU-W	NLU-W								
		Finishing · Schlichten	DF	HF	KF	KF	F1	F1	FF FN	11 UF LF	NF SM	14 19		PS5			NSU	NLU			C		VM			
		Semi-finishing Schichten-Mittlere Bearbeitung	PM	HM	KF KM	KF KM	M3	F2	FN	MF	GN	14 19	NM5	PS5	GH		NUX NGU	NSU	CM		C Stand. form		B25	HMP		
		Medium machining light roughing Mittlere Bearbeitung-leichte Schruppbearbeitung	DR	HM HR	KM QM	KM	M3	F2	UN	HP	GN NR			NM6	PM5		NUZ NGU NMU	NMU	CM		GC ZS		VK GR	C25	MT MG	MT PMR WT
		Wiper medium					W-M3 W-R4 W-R7		MW	MW	WG		NM	PM			NGU-W									
		Roughing Schruppbearbeitung	DR *NMA	HR	KR QR	KR UR	M5					NR		NR6		GH		NMU				ZS		MA		RT
Nonferrite Materials a e m e N	N	Finishing · Schlichten		LC		AL				LF	NF		PM2													
		Semi-finishing Schichten-Mittlere Bearbeitung		LC		AL		AL	GP		NF PP	AS						NAG				AH	AH	HA	AK	FL SA
		Medium machining-light roughing Mittlere Bearbeitung- leichtes Schruppbearbeitung		LH		AL		AL	GG-FS MS	HP	NMS													AR		
Heat resist. super alloys & Ti- alloys Warmf. Legi. & Ti-Legierungj	S	Finishing · Schlichten	NF EF	NF	NGP	MF	MF1		FS	GT-HP	SF PF	PF SM		PF4	FJ		NSU	NSU						VP1		
		Semi-finishing Schichten-Mittlere Bearbeitung	NF NM EM	NF	23	MM	MF1 M1		FS MS	GT-MF	SF PF	PF SM		PF5	MJ		NEX NUP	NSU NSK					VP2	AK		
		Medium machining-light roughing Mittlere Bearbeitung- leichte Schrappen	NM EM		MF	MM UM	M1		MS	MT-LF	PP TF			PS5	MS		NMU	NSK					VP3	HMP	SU	
		Roughing Schruppbearbeitung	ER		SR		MR3 MR4		RP		TF HTW NR				GJ								VM			

Coated Cemeled Carbide CVD - beschichtetes Hartmetall CVD

ISO	ZCC-CT	Sandvik	Kennametal	Sumitomo	Mitsubishi	Toshiba Tungaloy	Kyocera	Walter	Iscar	SECO	Korloy	Ingersoll Tague Tec	
I hat S	P	P01	GC4005 GC4205	KCP05 KC9105	AC805P	UE6005 UE6105	T9005 T9105	CA5505	WPP01 WPP05	IC8150 IC9150	TP0500 TK1001	TT8115 TT8125	
		P10	YBC151 YBC152 YBC152F YBC252 YBC251 YBC252F	GC1515 GC4015 GC4215 GC4025 GC4225	KCP05 KC9105 KCP10 KC9110	AC810P AC700G	UE6105 UC6110	T9005 T9015 T9115	CA5505 CA5515	WPP10 WPP05	IC8150 IC8250 IC9150 IC9250 IC9015	TP1500 TP0500 TK2001	NC3010 TT8115 TT8125
		P20	YBC252 YBC251 YBC252F YBC351 YBC352 YBC352F	GC4015 GC4215 GC4025 GC4225	KCP10 KCP25 KC9125	AC820P AC900G AC2000	UE6110 UE6020	T9015 T9115 T9025 T9125	CA5525 CA5535	WPP20 WPP10	IC8150 IC8250 IC9250 IC9025	TP2500 TP200	NC3220 NC3120 TT8125 TT3500 TT8115
		P30	YBC252 YBC252F YBC351 YBC352 YBC352F	GC4025 GC4225 GC4035 GC4235	KCP25 KCP30 KC9125 KC8050	AC830P AC820P AC3000	UE6020 UH6035 US735	T9025 T9125 T9035 T9135	CA5535	WPP30 WPP20	IC8250 IC8350 IC9350	TP2500 TP3500	NV3030 NC5330 NC500H TT5100 TT8135
		P40	YBC351 YBC352 YBC352F	GC4035 GC4235	KCP40 KC9140	AC830P AC3000	UE6035 UH6400	T9035 T9135	CA5535	WPP30 WAP30	IC9350	TP3500 TP40	NC5330 TT8135 TT7100
Stainless Steel Rostfreier Stahl	M	M10	YBM151 YBM153 YBM153 (F)	GC2015 GC1515	KCM15	AC610M	T9115	CA6515	WAM10	IC8250 IC9250 IC6015	TP200 TM2000 TK2001	TT9215 TT9225	
		M20	YBM251 YBM253 YBM253 (F)	GC2015 GC2025	KCM15 KCM25 KC9225	AC610M AC630M	US7020	T6020 T9125	CA6515	WAM20	IC8250 IC9350 IC9025 IC6025	TM2000 TP200 TP2500	NC9025 TT5100 TT9225 TT9235
		M30	YBM351 YBM253 YBM253 (F)	GC2025 GC4225 GC4235	KCM25 KCM35 KC8050 KC9225 KV9240	AC630M AC830P AV3000	US735	T6030	CA6525	WAM30 WAM20	IC8305 IC9305 IC9025	TP3500 TM4000	TT5100 TT7100 TT9235
		M40	YBM351	GC4235	KCM35 KC9240 KC9245	AC630M AC830P AC3000	US735	T6030	CA6525	WAM30	IC635	TP3500 TP40	TT7100
Cast iron · Guss	K	K01	YBD052 (F) YBD102 (F)	GC3005 GC3205 GC3210	KCK05	AC405K AC410K	UC5005 UC5105 UC5015 UC5115	T5105	CA4505	WAK10	IC5005	NC6205 TT1300	
		K10	YBD052 (F) YBD102 (F) YBD152 (F)	GC4205 GC3210 GC3215 GC4215	KCK05 KCK15 KC9315	AC410K AC415K AC420K AC700G	UC5005 UC5105 UC5015 UC5115	T5105 T5115	CA4505 CA4515 CA4010 CA4115	WAK10 WAK20	IC5005 IC9015 IC9007 IC8150 IC5010 IC428 IC4028 IC9150	TK1001 TK2001 TK1000 TK2000 TP0500	NC6210 NC315K TT1300 TT7310
		K20	YBD152 (F) YBD252 (F)	GC3210 GC3215 GC4205 GC4215	KCK15 KCK20 KC9315 KC9325	AC420K AC900G	UC5015 UC5115	T5115 T5125 T9125	CA4515 CA4010 CA4115 CA4125	WAK20	IC5010 IC428 IC4028 IC9150	TK2000 TK2001 TP1500 TP200	NC5330
		K30	YBD252 (F)		KCK20 KC9320 KC9325			T5125	CA4515 CA4120	WAK30		TK2000 TP2500	





ISO	ZCC-CT	Sandvik	Kennametal	Sumitomo	Mitsubishi	Toshiba Tungaloy	Walter	Kyocera	Iscar	SECO	Korloy	Ingersoll Tague Tec		
I ha S	P	P01						PR915						
		P10	YBG102 YBG105	GC1515 GC1125 GC1025	KC5010 KCU10		VP15TF UP20M	AH710	WSM10	PR930 PR1005	IC507 IC570 IC907 IC908 IC520N		TT9030	
		P20	YBG202 YBG205	GC1515 GC1125 GC1025	KC5010 KCU10		VP15TF VP20MF UP20M	AH725 SH730 AH120	WSM10 WSM20 WSM21	PR930 PR1005 PR1025 PR1225	IC520N IC530N IC507 IC570 IC907 IC908	TS2000 TS2500	TT7220 TT9020 TT9030	
		P30	YBG302	GC1125 GC2035	KC5025 KCU25	AC530U	VP20MF UP20M	AH725 SH730 J740	WSM30	PR660 PR1025	IC3028 IC1008	TS2500	PC5300	TT8020 TT7220 TT9020
		P40		GC2035				J740		PR660	IC3028 IC1008			TT8020
Stainless Steel Rostfreier Stahl	M	M10	YBG102 YBG105	GC1105 GC1115 GC1025 GC1125 GC1515	KC5010 KCU10	EHZ10 AC510U	VP15TF UP20M	AH710	WSM10	PR915 PR1005	IC520N IC520 IC507 IC570 IC807 IC907	TS2000	PC8110	TT5030 TT9030 TT9020 TT5080
		M20	YBG202 YBG205	GC1105 GC1115 GC1025 GC1125 GC1515	KC5010 KCU10	AC520U	VP15TF VP20MF UP20M	AH120 AH725 SH730	WSM10 WSM20 WSM21	PR915 PR930 PR1025	IC530N IC507 IC807 IC907 IC3028 IC1008	TS2000 TS2500	PC5300	TT9030 TT9080 TT9020
		M30	YBG302	GC1125 GC2035	KC5025 KCU25	AC530U	VP20MF UP20M	AH725 SH730 J740	WSM20 WSM21 WSM30	PR930 PR1025 PR1125	IC3028 IC1008	TS2500	PC9330	TT8020
		M40		GC2035					WSM30	PR1125 PR1225				TT8020
Cast iron Guss	K	K01												
		K10	YBG102		KC5010 KCU10		VP15TF	GH110 AH110 AH710				TS2000		
		K20	YBG202		KC5025 KCU25		VP15TF	AH120 AH710			IC1008	TS2000 TS2500		
		K30	YBG302								IC1008	TS2500		
Heat resist. super. all. & Ti- alloys Warmf. Legi. & Ti- Legierung	S	S01					VP05RT	AH905				TT5030 TT5080		
		S10	YBG102 YBG202 YBG105 YBG205	GC1105 GC1115	KC5010 KCU10 KC5510 KCS10	AC510U EH510Z	VP05RT VP10RT	AH725 AH110	WSM10	PR1305 PR1310 PR1325	IC507 IC807 IC907	TS2000	PC8110	TT5030 TT5080 TT9080
		S20	YBG202 YBG205	GC1205 GC1125 GC1515	KC5010 KCU10 KC5025 KCU25 KC5525	AC520U EH520Z	VP10RT VP15TF	AH725 SH730 AH120	WSM20 WSM21 WSM30	PR1325	IC507 IC807 IC907	TS2000 TS2500	PC5300	TT8020 TT9080
		S30	YBG302			AC520U	VP15TF		WSM30	PR1125	IC3028	TS2500		
Nonferrite Mat. me N	N	N01												
		N10	YBG102 YBG105	GC1125 GC1025 GC1515	KC5410					WXN10	IC520			
		N20			KC5410									

date

Coated Cemeted Carbide PVD - beschichtetes Hartmetall PVD

General Technical Inform - Allgemeine Technische Info

Cutting material comparison table-Turning · Schneidstoff Vergleichstabelle-Drehen

■ Cermet

ISO		ZCC-CT	Sandvik	Kennametal	Sumitomo	Mitsubishi	Toshiba Tungaloy	Walter	Kyocera	Iscar	SECO	Korloy	Ingersoll Tague Tec	
I hat S	P	P01	YNG051	CT5005	KTP15	T110A			TN30 TN6010 PV30 PV60 PV7010	IC520N		CC105	PV3010 CT3000	
		P10	YNG151 YNG151C	CT5005 CT5015 GC1525	HT2 TTI 15 KT315 KT325	T110A T1200A T1500A	NX1010 NX33 NX55 NX99 AP25N VP25N	NS520 NS730 AT520 GT530 GT730		TN30 TN60 PV90 TN6020 PV7020 PV7010 PV7025	IC520N IC530N IC20N	C15M CMP TP1020 TP1030	CN1000 CC115	PV3010 CT3000
		P20	YNG151 YNG251 YNG151C	CT5015 GC1525 CT530	TTI 15 KT315 KT325	T1200A T1500A T2000Z	NX2525 NX33 NX99 AP25N VP25N UP35N	NS520 NS730 NS539 AT530 GT530 GT730 J530		TN60 TN6020 TN90 PV7020 PV90	IC530N IC20N IC30N	C15M CMP	CC125 CN20 CN2000	
		P30				T1200A T3000Z	UP35N VP45N	NS530		TN60 TN90 TN6020	IC30N		CN30	
		P40					VP45N							
Stainless Steel Rostfreier Stahl	M	M10	YNG151 YNG151C	CT5005 GC1525 CT530	HT2 KTP15 KT315 KT325	T1200A T1500A	NX2525 AP25N		TN60 TN90 TN6020 TN6010 TN7010 TN7025	IC520N IC530N IC20N	C15M		PV3010 CT300	
		M20	YNG151	CT5015	HT2	T1200A T1500A T2000Z		J530		TN60 PV90 TN6020 PV7020 TN90	IC520N IC20N IC530N IC30N	C15M TP1020		PV3010 CT300
		M30				T3000Z		J530			IC30N			
		M40												
Cast iron Guss	K	K01			HT2 KTP15	T110A T1200A T1500A			TN30 PV7005			CN1000	PV3010 CT300	
		K10	YNG151 YNG151C	CT5005 CT5015 AT520	HT2 KT315 KT325	T110A T1200A	NX1010 AP25N	NS520 GT520 NC530		TN30 PV30				PV3010 CT300
		K20		CT5015		T110A	NX2525 AP25N	NS520 NS530 GT520						
		K30												
Heat resist. super all. & + T alloys Warmf. Legi. & Ti-Legierung	S	S01												
		S10												
		S20												
		S30												
Nonferrite Mat.	N	N01		CT5005	HT2 KT325									
		N10		CT5005 CT5015	HT2									
		N20												

di a e me N



Technical Info
Technische Info



Cutting material comparison table-Turning · Schneidstoff Vergleichstabelle-Drehen ■ Carbide uncoated · Hartmetall Unbeschichtet

ISO	ZCC-CT	Sandvik	Kennametal	Sumitomo	Mitsubishi	Toshiba Tunggaloy	Walter	Kyocera	Iscar	SECO	Korloy	Ingersoll Tague Tec	
Nonferriete Mat. di e me N	YD101 YD201	H10 H13A	THM-F HWK10 HWK15 K313 KU10 K68	H1	RT9005 HTI10	KS05F	WK01 WK10	KW10	IC20	KX HX	H01	K10	
													N01
													N10
	YD101 YD201		THM-F HWK10 HWK15						IC20	KX HX			

CVD milling grades - CVD Fräsen Klasse

Material / Class		ZCC-CT	Sandvik	Kennametal	Sumitomo	Mitsubishi	Toshiba Tungaloy	Kyocera	Walter	Iscar	SECO	Korloy	Ingersoll Tague Tec	
I hat S	P	P05	K20W GC4220			F7010								
		P10	K20W GC3040 GC4220 GC4230		ACP100	F7010				IC4100 IC5100	MP1500	NC5330 NCM325	IN6505 IN6520	
		P20	YBC301 YBC302 YBC251 YBC253	GC3040 GC4230		CS3000	FH7020	T3130		WKP25 WKP25S	IC4050 IC4100 IC5100 IC5400	MP1500 MP2500 MS2500 T25M	NC5330 NCM325	IN6505 IN6520 IN7035
		P30	YBC301 YBC302 YBM253 YBM351	GC2040 GC4240	KC930M KC935M	CS3000	F7030	T3130		WKP35 WKP35S WTP35	IC4050 IC5400	MK3000 T25M T350M	NCM325	IN7035 IN6530
		P40	YBC401 YBM351	GC2040 GC4240								T350M		IN6530
Stainless Steel Rostfreier Stahl	M	M10		GC4230		F7010					MP1500	NCM325 NC5330	IN6520	
		M20	YBM251 YBM253	GC4230			F7020	T3130			IC4050	MP1500 MP2500 MS2500 T25M	NCM325 NCM335	IN7035 IN6520 IN6505
		M30	YBM351	GC2040 GC4240	KC930M KC935M		F7030	T3130		WTP35		MP2500 MS2500 T25M T350M	NCM335	IN6530 IN7035 IN6505
		M40		GC2040 GC4240								T350M		IN6530
Cast iron · Guss	K	K05	YBD152		KCK15	F7010 MC5020					DT7150 IC4100			
		K10	YBD152 YBD252	K20W	KCK15	ACK200	F7010 MC5020	T1115		WAK15	DT7150 IC4100 IC4010	MP1500 MK1500	NC5330	IN6520
		K20	YBD252	K20W		ACK200		T1115		WKP25 WKP25S	DT7150 IC4100	MP1500 MP2500 MS2500 T25M MK1500	NC5330	IN6530 IN6515 IN6520
		K30			KC930M KC935M					WKP35 WKP35S	IC4050	MK3000 MP2500 MS2500		IN6530 IN6515



CVD milling grades - CVD Fräsen Klasse

Material / Class	S05	S10	S20	S30	N05	N10	N20	H05	H10	H20
ZCC-CT										
Sandvik				GC2040					K20W	K20W GC3040
Kennametal										
Sumitomo										
Mitsubishi										
Toshiba Tungaloy										
Kyocera										
Walter				WTP35						
Iscar										
SECO	MK3000		MP2500 MS2500 T25M	MM4500 T350M			MP2500 25M			
Korloy										
Ingersoll Tague Tec			IN7035 IN6520							
Material / Class	S Super alloys Ti-Legierung				N Nonferrite materials			H Hadened materiel el & mdH		



PVD milling grades - PVD Fräsen Klasse

Material / Class	ZCC-CT	Sandvik	Kennametal	Sumitomo	Mitsubishi	Toshiba Tungaloy	Kyocera	Walter	Iscar	SECO	Korloy	Ingersoll Tague Tec		
I hat S	P	P05			ACZ120	VP05HT	GH130		IC903					
		P10	YBG102	GC1010 GC1025 GC1020	KC522M KC525M KC610M KC643M KC715M	ACZ10M ACZ20W	VP10H	AH120 GH130	PR730 PR1225 PR1525	WHX15 WHH15 WXM15	IC903 IC950 IC1008	F15M	IN2004 IN2006	
		P20	YBG202 YBG252	GC1020 GC1025 GC1010 GC2030	KC522M KC525M KC643M KC715M KC725M	ACP200 ACZ330 ACX70 ACW30 AC350 ACZ50M	VP15TF VP20M VP20RT	AH725 AH120 AH130 AH330 AH725 AH730 GH330	PR630 PR830 PR730 PR1225 PR1230 PR1525	WXM15	IC810 IC380 IC830 IC900 IC908 IC910 IC950 IC1008	F25M MP3000	PC3500 PC3600	IN2006 IN1030 IN2004 IN2005 IN2015 IN2030 IN2505 IN2540
		P30	YBG302	GC1030 GC2030	KC530M KC725M KC735M	ACP200 ACP300 ACZ50M ACZ330 ACZ350 ACX70 ACW30 AC350	VP30RT	AH740 AH130 AH140	PR630 PR660 PR830 PR1230	WXM35	IC300 IC328 IC830 IC900 IC928 IC350 IC808 IC908	F30M MP3000	PC3500 PC3600 PC5300 PC3545 PC9570T	IN1030 IN2005 IN2015 IN2030 IN2035 IN2040 IN2505 IN2530 IN4035
		P40		GC1030	KC735M	ACP300 ACZ350		AH140 AH750		WXP45 WSP45 WSP46	IC300 IC328 IC928	F40M	PC5300 PC3545	IN2035 IN2040
Stainless Steel Rostfreier Stahl	M	M10		GC1020	KC522M KC610M KC643M KC715M	ACZ20W ACZ350 EH20Z	AH330 GH110 GH130	PR730 PR1225 PR660 PR1525		PR730 PR660 PR1225 PR1525	F15M	PC8110	IN2505	
		M20	YBG202 YBG205 YBG252	GC1020 GC1025 GC1030 GC203	KC522M KC525M KC610M KC715M KC725M	ACP200 ACZ50M ACZ20M ACZ350 EH20Z AC350	VP15TF VP20RT	AH725 AH730 GH110	PR730 PR1025 PR660 PR1225 PR1525	WXM15	PR730 PR660 PR1025 PR1225 PR1525	F25M MP3000	PC5300 PC8110 PC9530	IN2005 IN2015 IN2505
		M30	YBG302	GC1040 GC203	KC525M KC530M KC725M KC735M	ACP300 ACZ50M ACX80 AC350	VP30RT	AH740 AH120 AH130 GH330 GH340				F30M MP3000	PC9530 PC3545 PC9570T	IN1030 IN2015 IN2030 IN2035 IN2530 IN4035
		M40		GC1040	KC530M KC735M	ACP300 ACX80		AH140 AH750 GH330 GH340		WSM35 WSM36 WXM35		F40M	PC3545	IN1030 IN2030 IN2035 IN2530 IN4035
Cast iron · Guss	K	K05		GC1010	KC510M	ACZ10M ACZ120 ACZ310	AH330	PR905 PR1210 PR1510			MH100C	PC8110	IN2510	
		K10	YBG102 YBG152	GC1010	KC510M KC520M KC620M KC643M	EH20Z ACZ310		AH120 AH330 AH725	PR905 PR1210 PR1510	WXH15 WHH15 WXM15	IC810 IC950 IC1008	F15M MK2000	PC6510	IN2004 IN2010 IN2510
		K20		GC1020	KC520M KC620M KC725M	ACK300 EH20Z ACX80 ACW30	VP15TF	GH130			IC328 IC830 IC950 IC350 IC808 IC908 IC1008	F25M MK2000 MO3000	PC6510 PC5300	IN1030 IN2004 IN2010 IN2015 IN2030 IN2505
		K30		GC1020	KC620M KC725M	ACK300 ACZ50M					IC328 IC830 IC900 IC908 IC350 IC808 IC908	F30M F40M MP3000	PC5300 PC9570T	IN2005 IN2015 IN2030 IN2505



General Technical Inform - Allgemeine Technische Info

PVD milling grades - PVD Fräsen Klasse

Material / Class	ZCC-CT	Sandvik	Kennametal	Sumitomo	Mitsubishi	Toshiba Tungaloy	Kyocera	Walter	Iscar	SECO	Korloy	Ingersoll Tague Tec
Super alloys Ti-Legierung	S05									MH1000 F15M	PC8110	
	S10	YBG102 YBG202 YBG205		ACZ20W	VP15TF		PR905 PR1210 PR1510		IC808	NH1000 F15M F25M	PC5300	
	S20	YBG202 YBG205	S30T GC1025 GC1030 GC2030	ACZ20W			PR905 PR1210 PR1510		IC908 IC380 IC900 IC903 IC908 IC928 IC830 IC808	F25M F30M	PC5300 PC3545	IN2005 IN2505
	S30		GC2030	ACZ50M				WSM35 WSM36 WSP45 WSP46 WXM35 WXP45	IC328 IC928 IC830	F40M	PC3545	IN1030 IN2030 IN2035 IN2530 IN4035
Nonferite materials N	N05		KC510M							MH1000 F15M		
	N10	YBG202	KC510M KC620M KC522M	EH20Z				WXN15		MH1000 F15M		
	N20		KC620M KC522M KC525M KC651M							F25M F30M F40M MP3000		
Hadened materiel H at e m dH	H05				VP05HT				IC903	MH1000 F15M	PC210F	IN2004 IN2006
	H10	YBG102	GC1010		VP10MF			WXH15 WHH15	IC900 IC808	MK2000 F30M MP3000	PC210F	IN2004 IN2005 IN2006
	H20	YBG202	GC1010 GC1025 GC1030		VP15TF				IC810 IC908	F30M F40M MK2000 MP3000		



Uncoated milling grades - Unbeschichtet Fräsen Klasse

ISO		ZCC-CT	Sandvik	Kennametal	Sumitomo	Mitsubishi	Toshiba Tungaloy	Walter	Kyocera	Iscar	SECO	Korloy	Ingersoll Tague Tec
Nonferrite Mat. dl at e me N	N01		H10	K115M K110M				WK10		IC20N		H01	IN04S
	N10	YD101		K313	EH520	HTi10		WKM	GW25	IC08	H15	G10	IN10K IN05S
	N20	YD201	H13A H10F	KMF	EH520	TF15		KMG40		IC28	H25		IN15K

